

New 130nm Itanium[®] 2 Processors for 2003

**Harry Muljono, Stefan Rusu,
Brian Cherkauer, Jason Stinson**

Intel Corporation, Santa Clara, CA



Outline

- **Processor highlights**
- **Itanium[®] 2 processor evolution**
- **Block diagram**
- **Power dissipation**
- **Package details**
- **Front-side bus interface**
- **DFT and DFM features**
- **Performance details**
- **System level implementation**
- **Summary**

Itanium[®] 2 Processor 6M Highlights

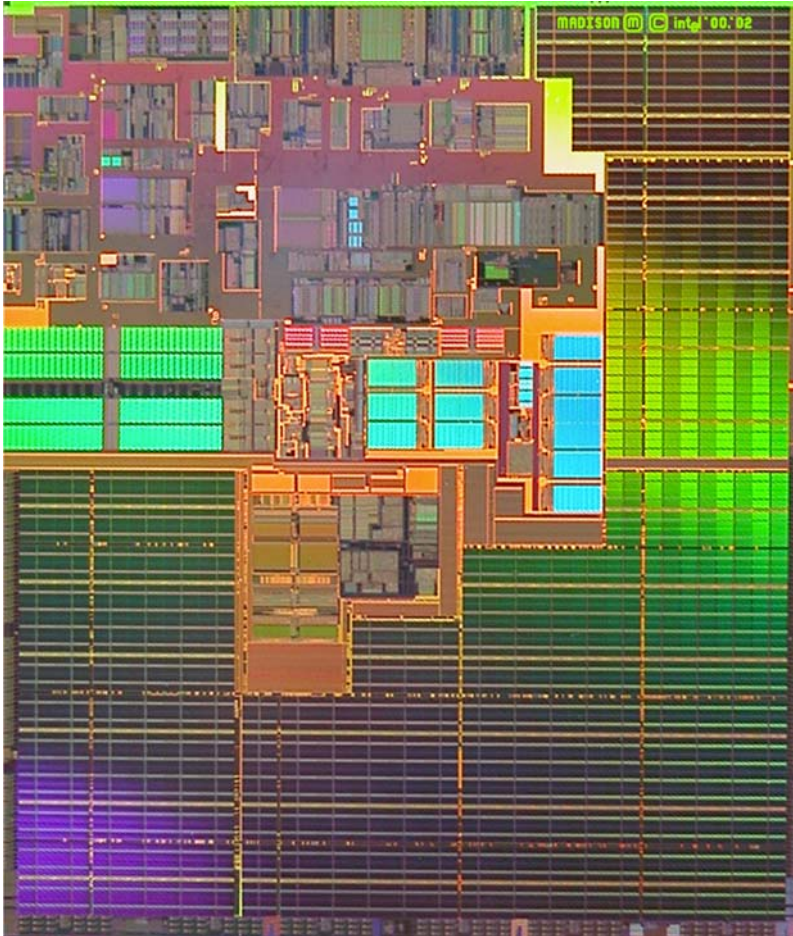

- 130nm process
- 410M transistors
- 374mm² die size
- 6MB on-die L3 cache
- 1.5GHz at 1.3V
- 6.4GB/s 400MT/s 4-way bus interface
- System compatible with existing Itanium 2 platforms
- Extensive RAS, DFT and DFM features

Largest microprocessor transistor count and on-die cache

Intel® Itanium® Processor Family Roadmap

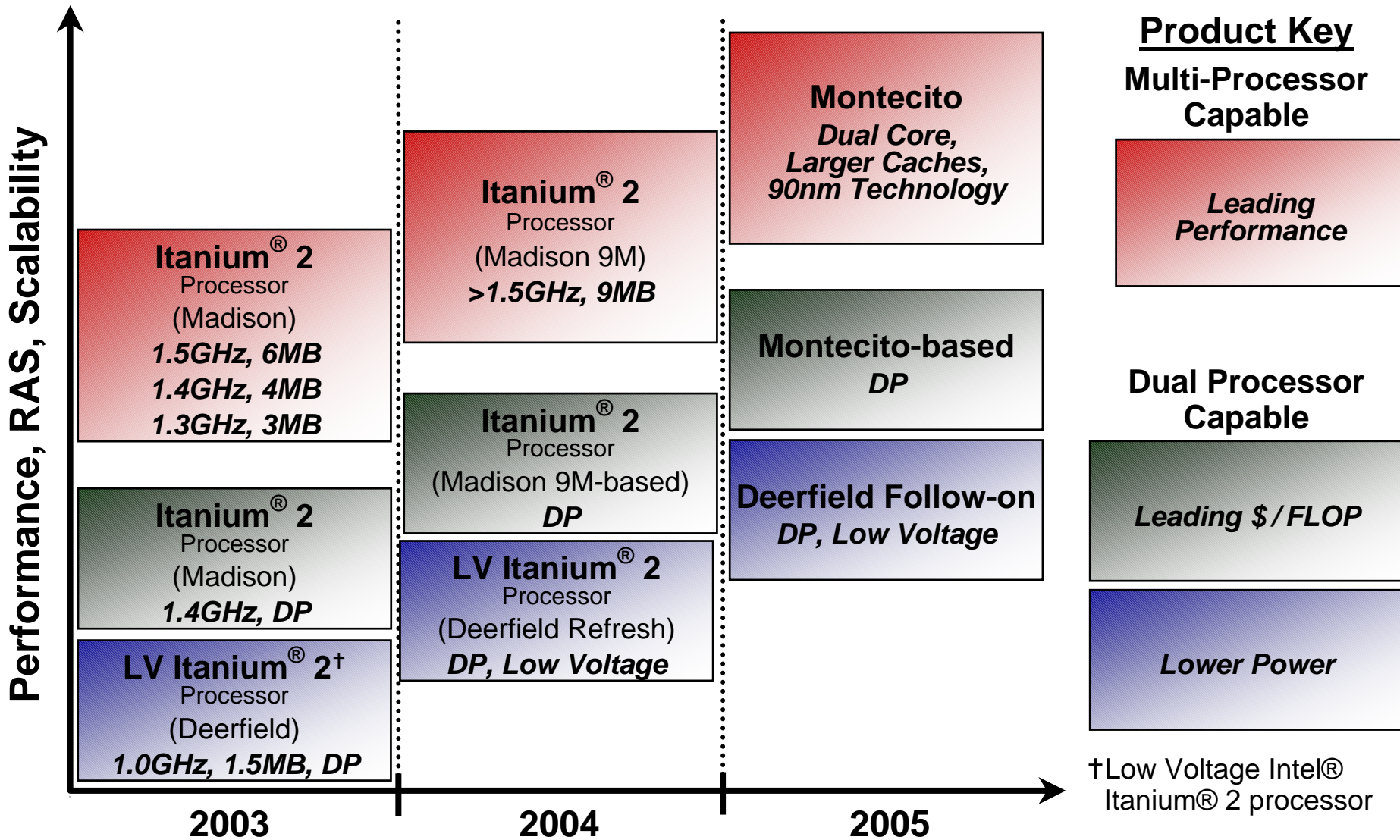

Next generation platforms with advanced features planned for '06 and beyond



Itanium® 2 Processor Evolution

Attribute	Itanium® 2 Processor	Itanium® 2 Processor 6M	Low Voltage Itanium® 2 Processor
Code name	McKinley	Madison	Deerfield
Architecture	Explicitly Parallel Instruction Computing		
Process	180nm	130nm	130nm
On-die L3 cache	3MB	6MB	1.5MB
Frequency	1.0GHz	1.5GHz	1.0GHz
Supply Voltage	1.5V	1.3V	1.1V
Max. Power	130W	130W	62W
Thermal Design Power	100W	107W	≤ 55W
Target market	MP servers, workstations	MP-servers, workstations	DP-servers, workstations

Thermal Design Power

- **Realistic** worst case application power
 - Based on various application loads
- **Approx. 90%** of theoretical max power (MPP)
 - MPP conditions are unrealistic for system applications
- **Thermal Design Envelope (TDE)** set at MPP level
 - Ensures system compatibility with future Itanium 2 processors

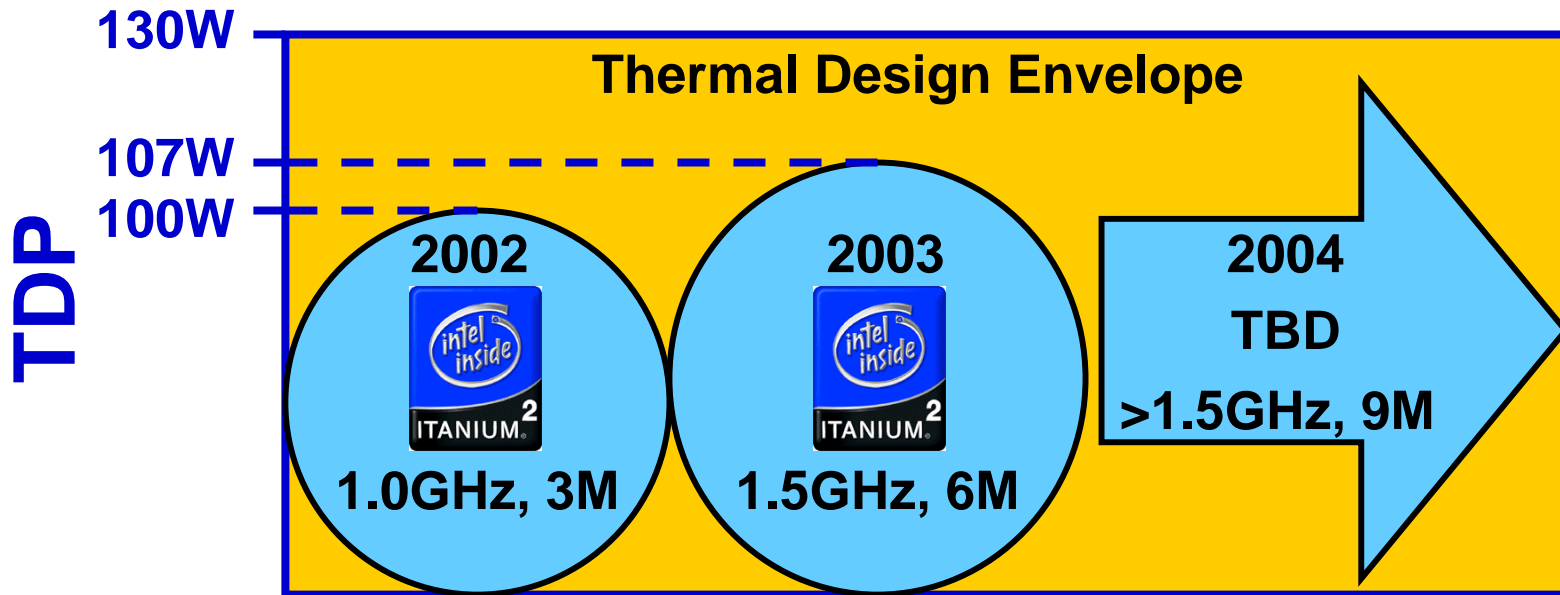

Itanium[®] 2 Processor-based System

Block Diagram

■ ECC protected
■ Parity protected

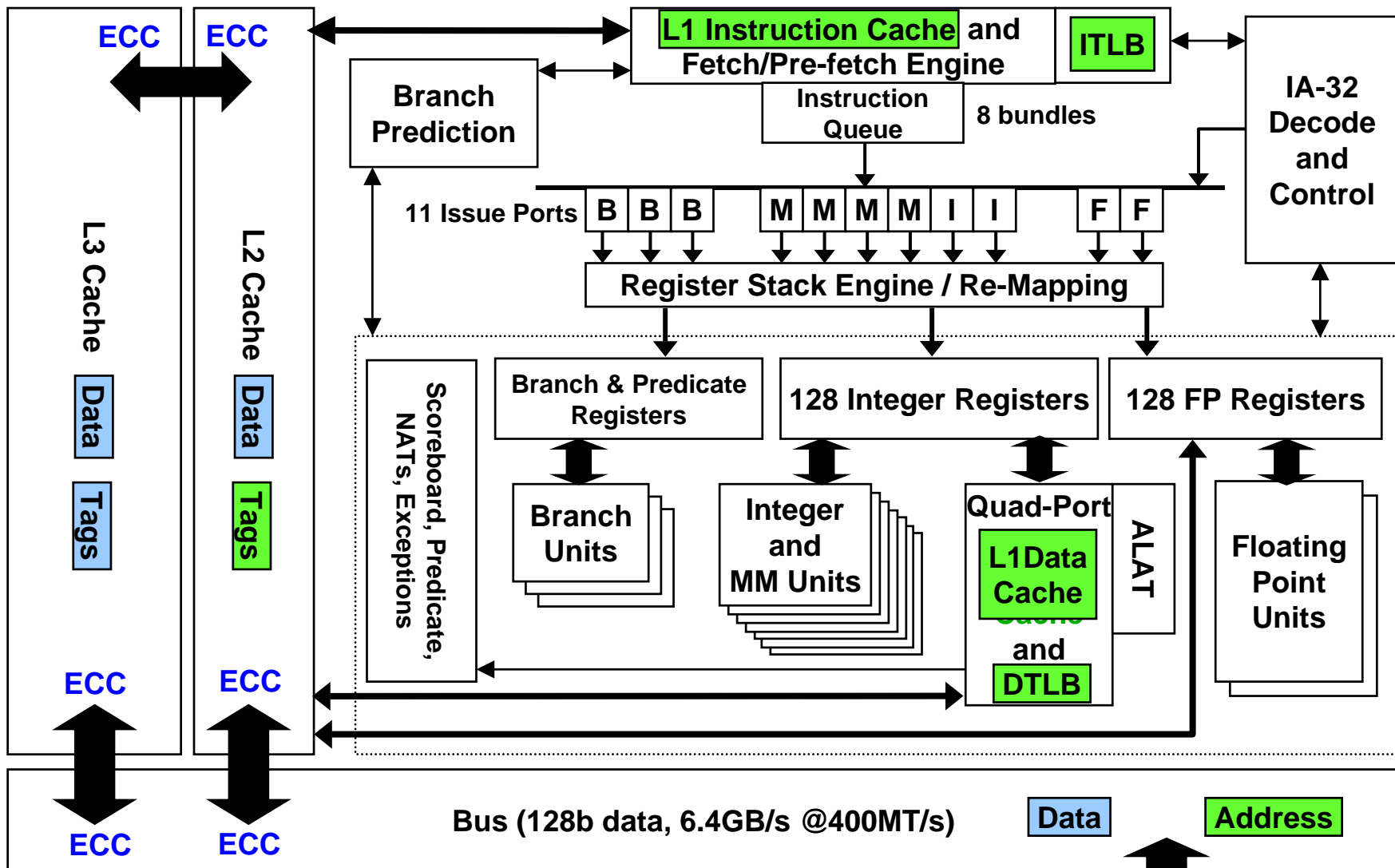

Itanium® 2 Processor 6M Cache Summary

Attribute	L1I	L1D	L2	L3
Size	16K	16K	256K	Up to 6M
Line Size	64B	64B	128B	128B
Ways	4	4	8	24
Replacement	LRU	NRU	NRU	NRU
Latency	1-Fetch:1	INT:1 FP: NA	INT: 5 FP: 6	14
Write Policy	-	WT (RA)	WB (WA)	WB (WA)
Bandwidth	R: 48GBs	R: 24GBs W: 24GBs	R: 48GBs W: 48GBs	R: 48GBs W: 48GBs

- **Compared to the original Itanium® 2 Processor:**
 - Cache bandwidths increased by 50%
 - L3 size and set associativity doubled

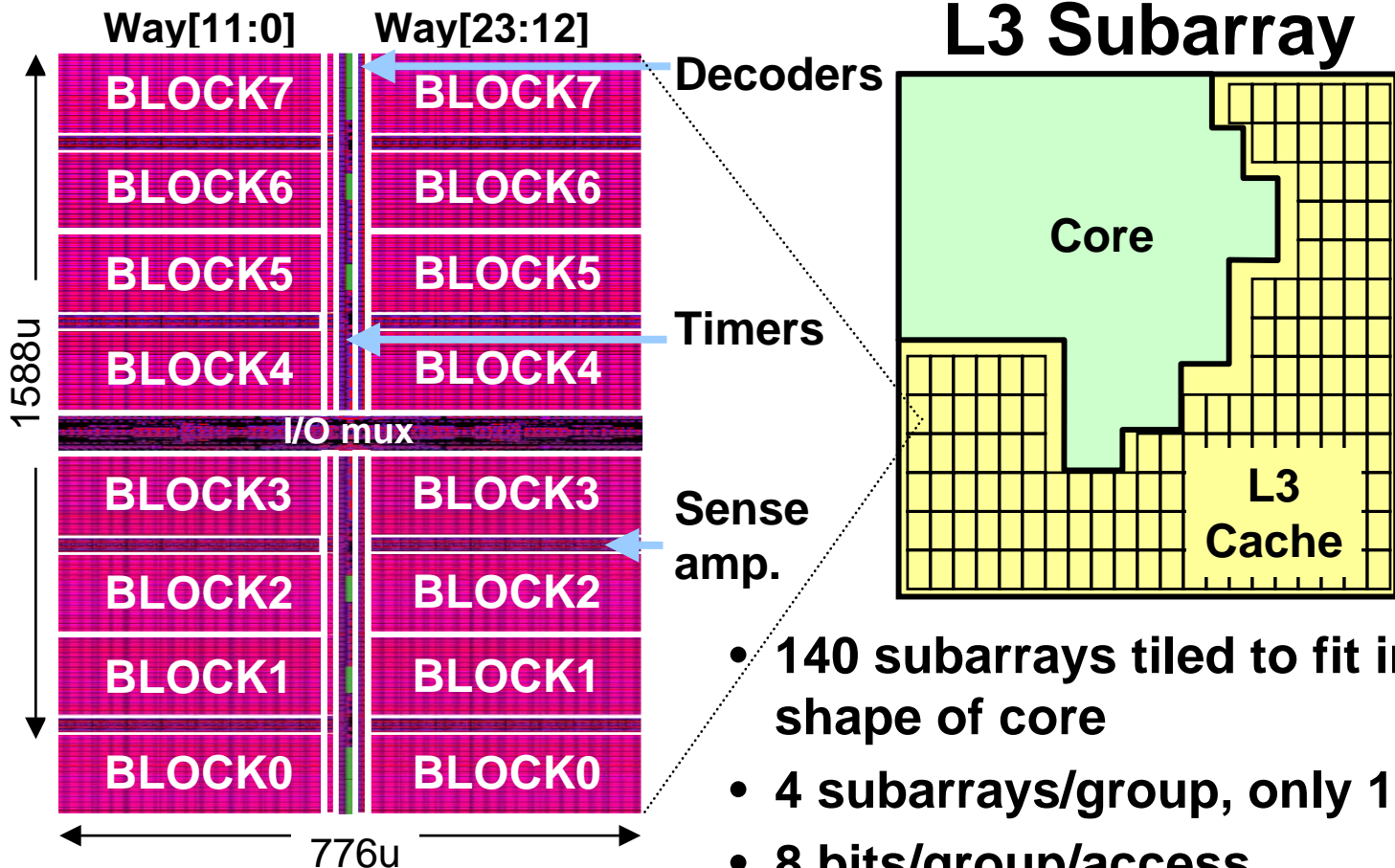

- 140 subarrays tiled to fit irregular shape of core
- 4 subarrays/group, only 1 is active
- 8 bits/group/access

Physical Address Decoding:

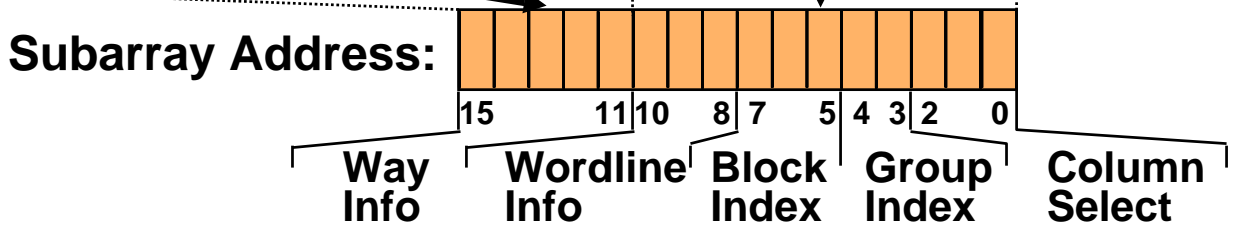

L3 Power Reduction Scheme

Previous Implementation

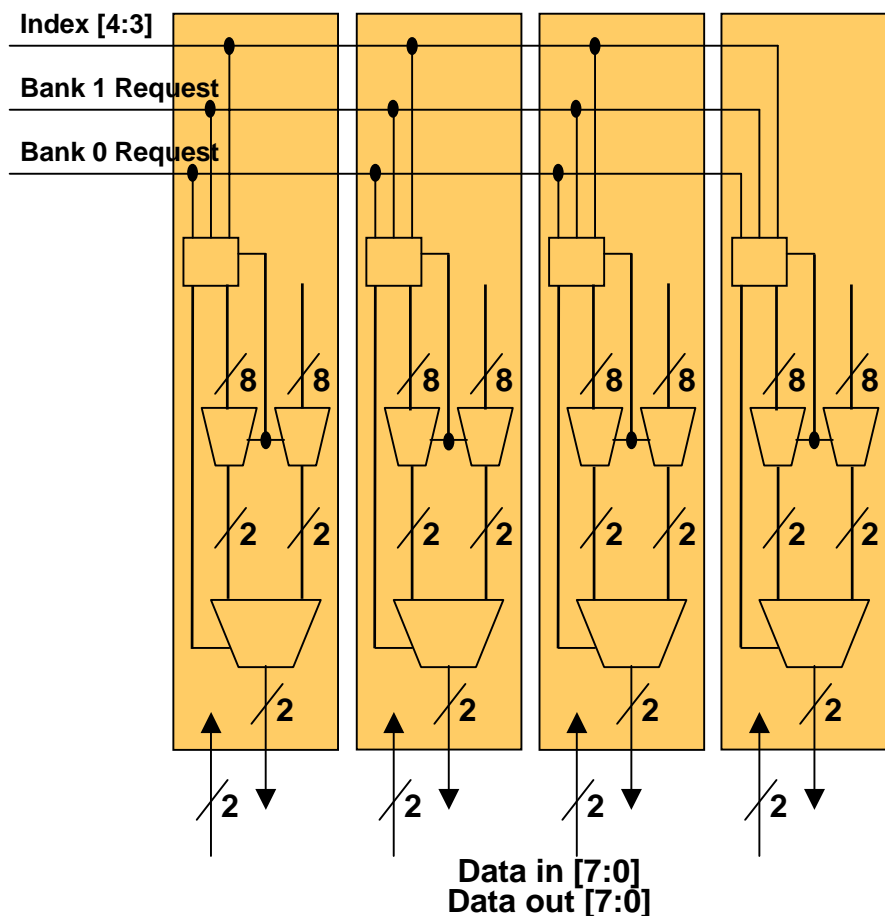

Two data bits per subarray
Index[4:3] enables 4 subarrays

This work

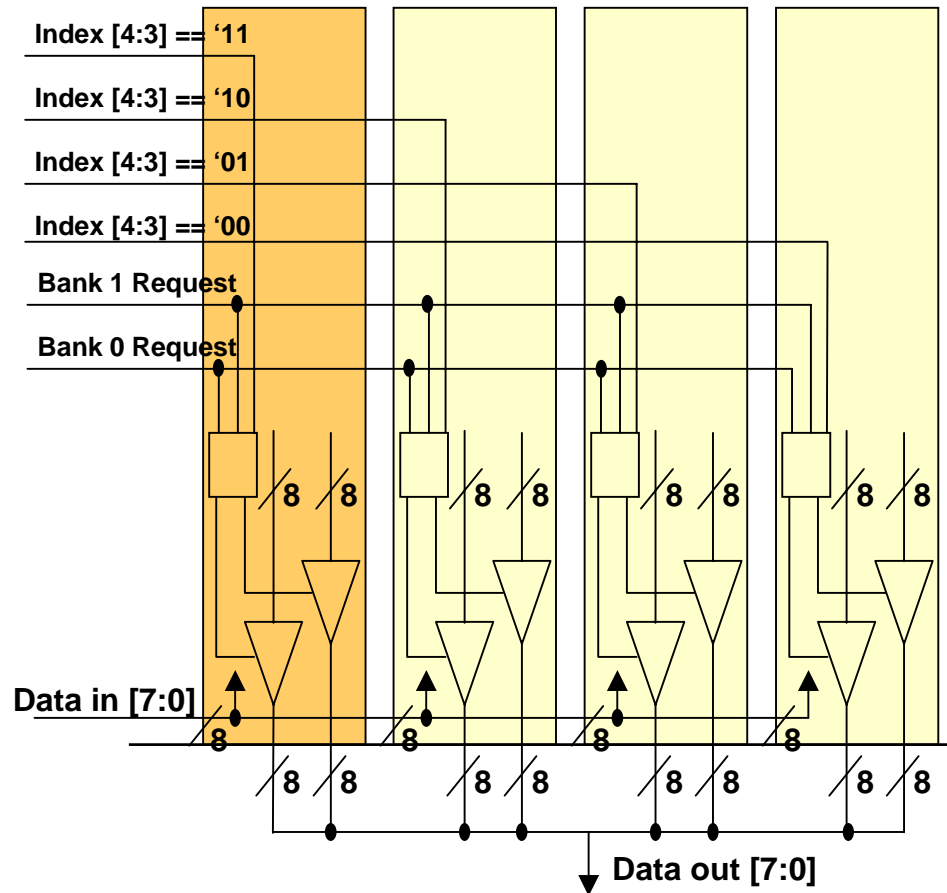

Eight data bits per subarray
Index[4:3] enables 1 subarray

Power

- Same thermal design envelope as the 180nm Itanium[®] 2 processor

- 50% frequency increase
- 2X larger L3 cache
- Leakage increased 3.5X

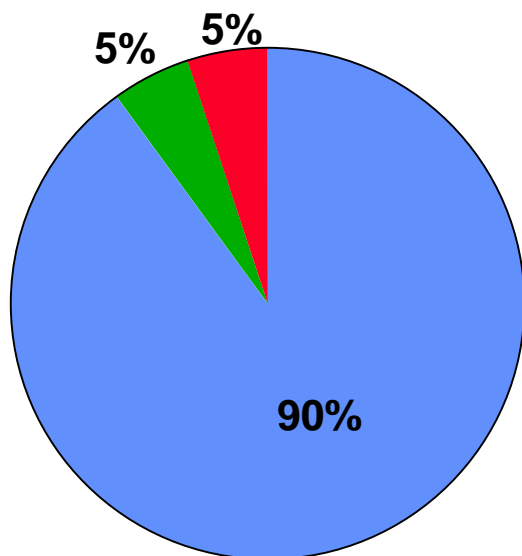
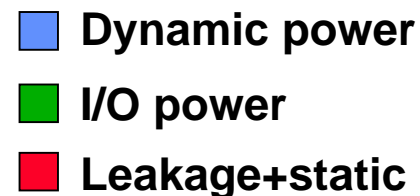

Itanium[®] 2
Processor 3M (180nm)

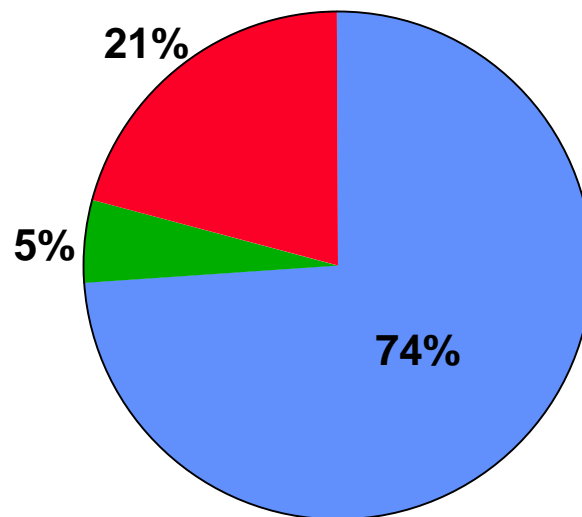

Itanium[®] 2
Processor 6M (130nm)

Itanium[®] 2 Processor 6M Package Details

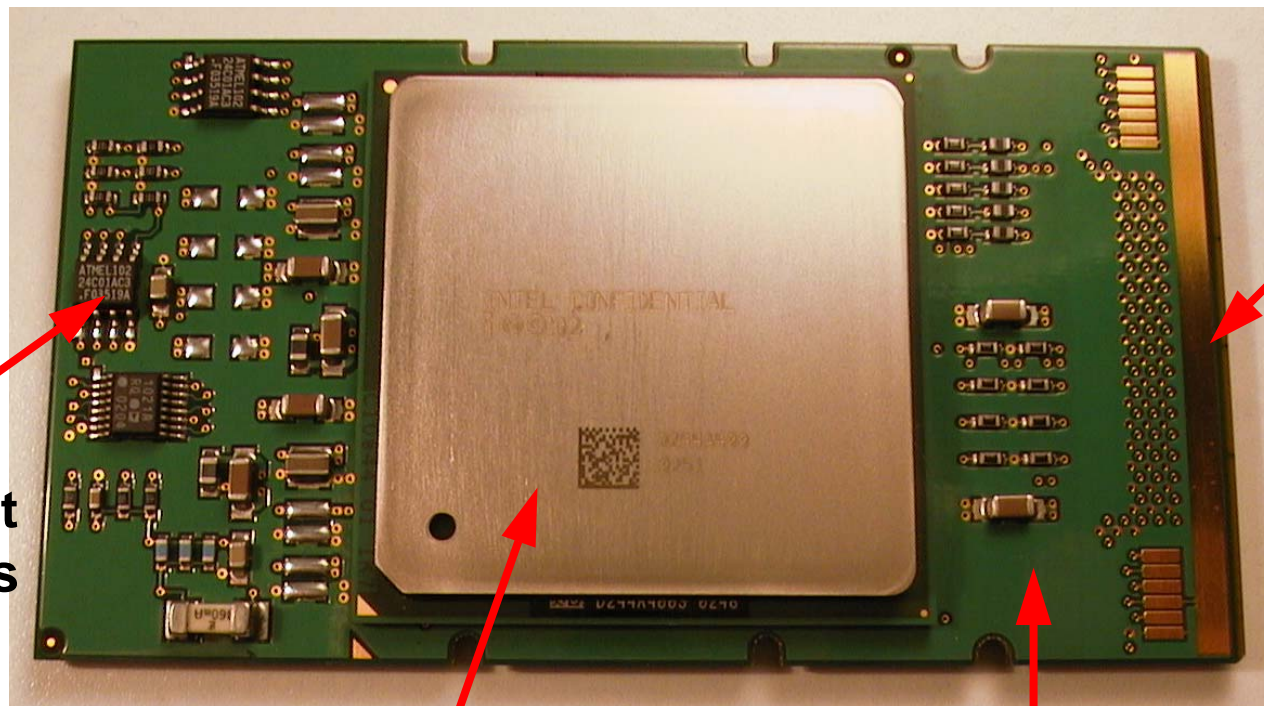

**Power
delivery
connector**

**Server
Management
Components**

**Flip-Chip BGA package with
Integrated Heat Spreader**

**Interposer
Substrate**

Package Decoupling

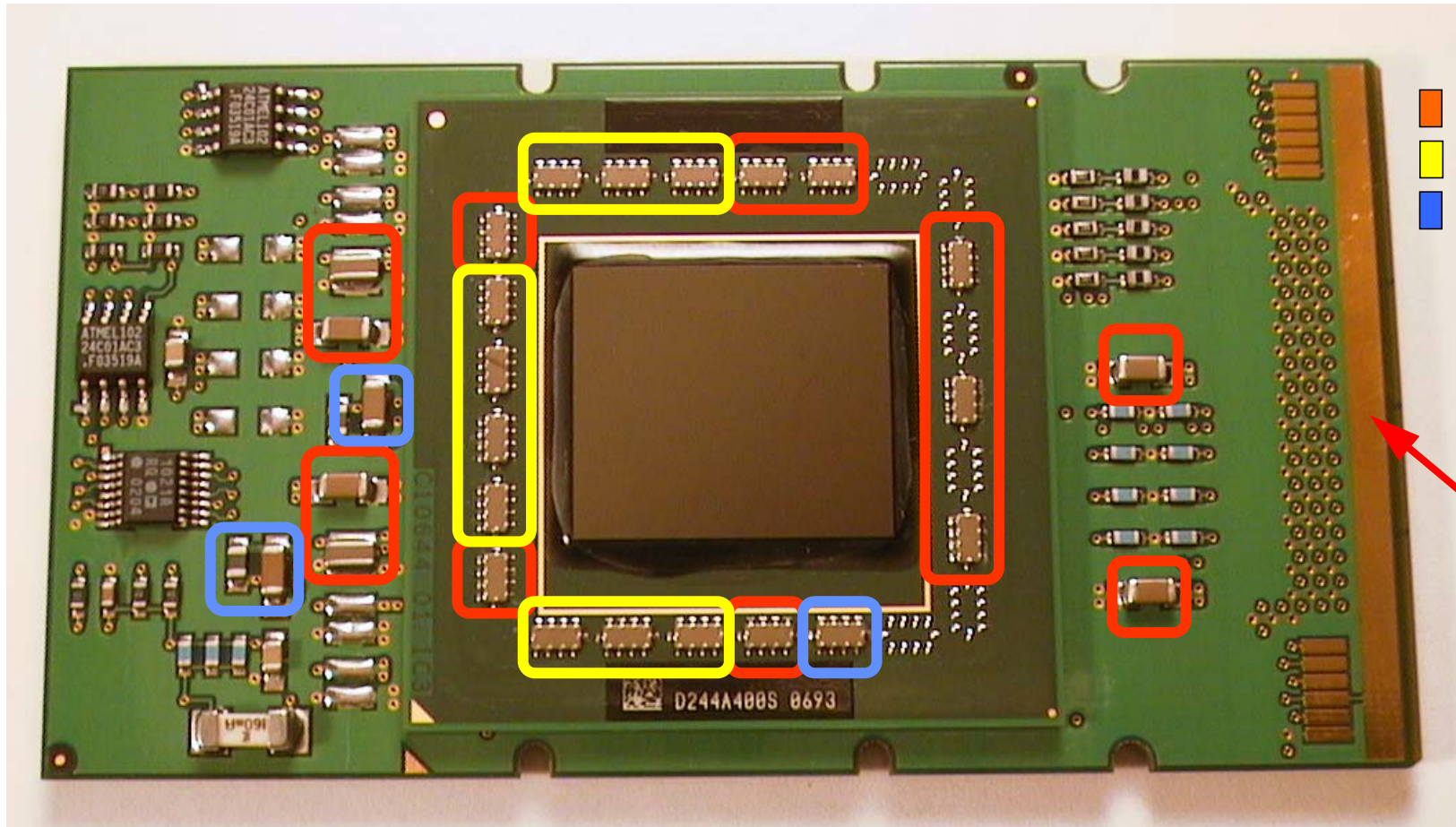

- Vdd (core)
- Vtt (FSB)
- PLL filter

→ Power delivery connector

Front Side Bus

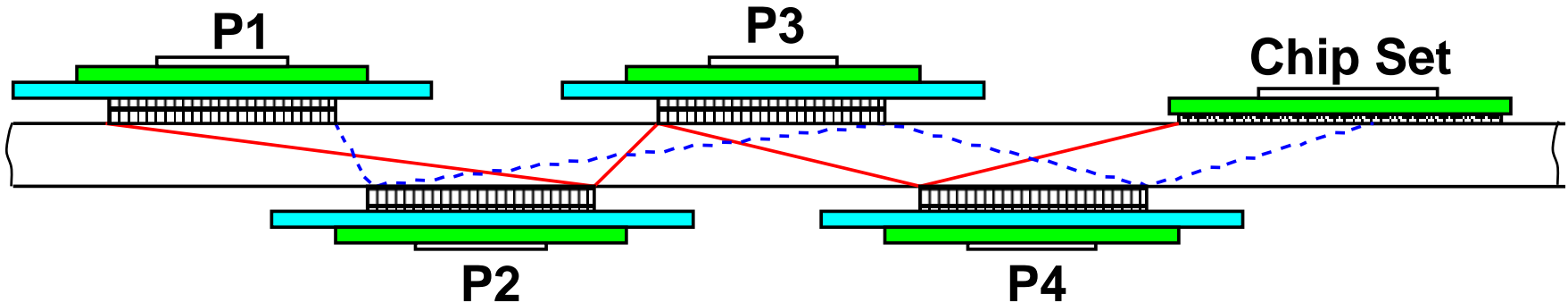

Interface Support	Glueless 4-way Multi-Processor
System Topology	Dual-sided board, staggered vias
Termination Voltage	1.2V, common ground with core
Voltage Reference	Ground-referenced, 0.75V Vref
Data Bus Width	128-bit
Data Bus Speed	400MT/s source synchronous
Data Strobes	1 differential strobe for 16b of data
Peak BW	6.4GB/s
Address, Control Speed	200MHz common clock

Front-Side Bus Topology

Previous implementation
Four linear stripes

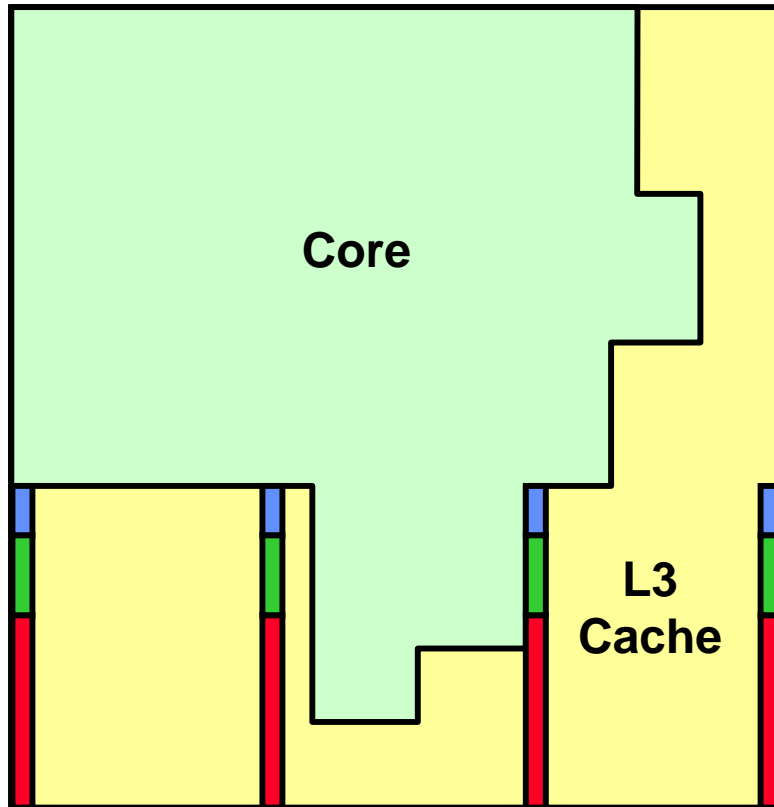

This work
U-shape

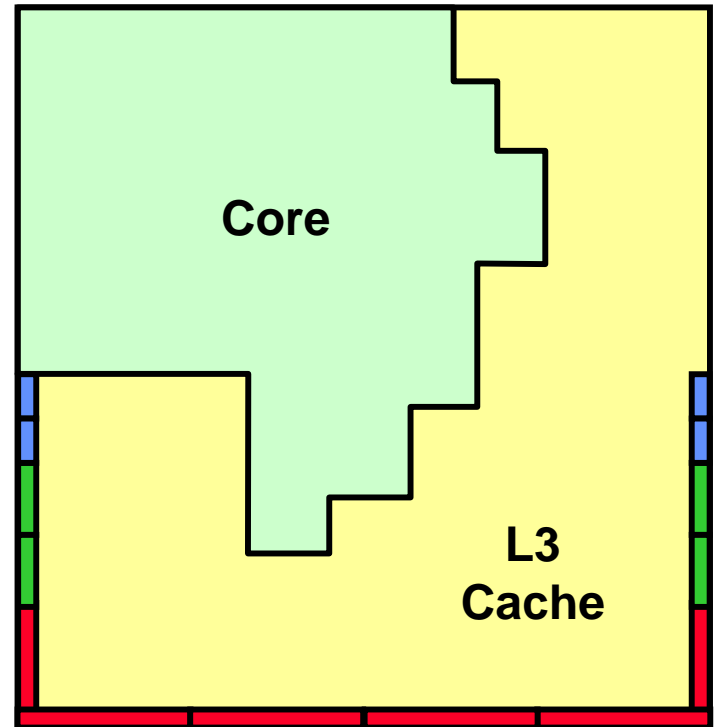

-  Data I/O
-  Address I/O
-  Control I/O

DFT/DFM Feature Summary

Feature	Itanium [®] Processor	Itanium [®] 2 Processor	This work
Scan Coverage	48K	140K	140K
Scanout Coverage	5.5K	24K	24K
Cache DAT Mode (major arrays)	Yes	Yes	Yes
L3 Redundancy / Repair	N/A	Dual	Quad
Weak-Write Test Mode	Fixed	Fixed	Programmable
IO DFT	Basic IO Loopback	Limited IO Loopback	Enhanced IO Loopback
Dynamic Frequency Adjustment	Multi-cycle shrink/stretch	Single cycle shrink/stretch	Multi-cycle shrink/stretch
On-die process monitors	No	No	Yes

Itanium® 2 Processor 6M:

Industry Leading Performance Results vs. Best RISC

Results as of 6/23/03.

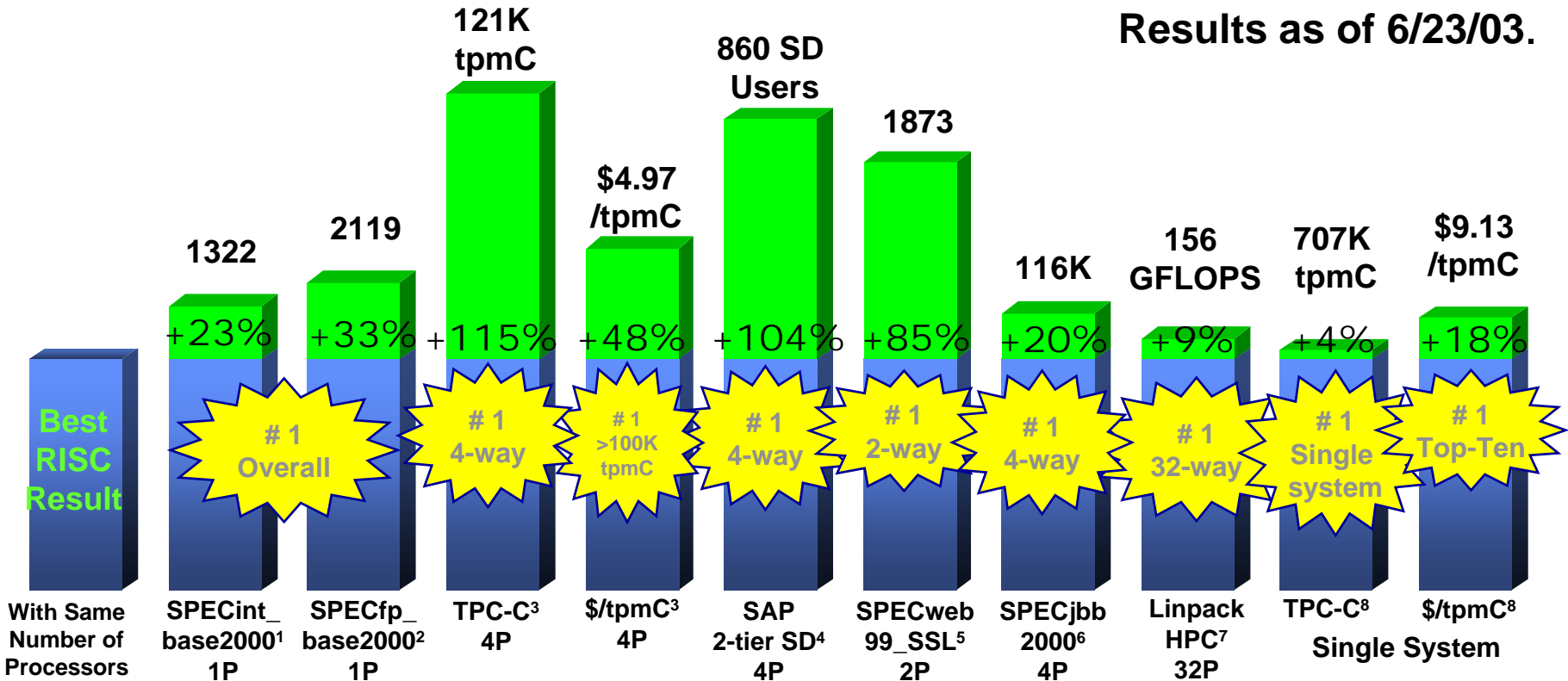

- Source: www.spec.org: Itanium® 2 processor results measured on HP Server rx2600 using Itanium® 2 processor 6M at 1.5GHz, HP-UX operating system and submitted to SPEC. SPECint* is a trademark of SPEC*. Best RISC result of 1077 on eServer pSeries IBM 690 using Power4+ 1.7GHz processor.
- Source: www.spec.org: Itanium® 2 processor results measured on HP Server rx2600 using Itanium® 2 processor 6M at 1.5GHz, RedHat Linux AS2.1 operating system and submitted to SPEC. SPECfp* is a trademark of SPEC*. Best RISC result of 1598 on eServer pSeries IBM 690 using Power4+ 1.7GHz processor.
- Source: www.tpc.org: Itanium® 2 processor results of 121,065 tpmC and \$4.97/tpmC on HP Server rx5670 using 4 Itanium® 2 processors 1.5GHz with 6MB L3 cache, 64GB memory, Microsoft Windows Server 2003 Enterprise Edition and Microsoft SQL Server 2000 Enterprise Edition 64-bit, availability date 8/1/03. Best published RISC result of 56,375 tpmC and \$9.44/tpmC on HP AlphaServer using 4 ES45 processors 1.25GHz, 32GB memory, availability 09/27/02.
- Source: www.sap.com/benchmark: Itanium® 2 processor results measured on HP Server rx5670 using 4 Itanium® 2 processors 1.5GHz with integrated 6MB L3 cache, 24GB of memory, HP-UX 11i, SAP rev 4.6 C, Oracle 9i. Best RISC result of 420 from www.sap.com/benchmark on AlphaServer ES45 1000MHz.
- Source: www.spec.org: Itanium® 2 processor result of 1873 on HP Server rx2600 using 2 Itanium® 2 processors 1.5GHz with 6MB L3 cache, 12GB memory, HP-UX, Zeus 4.2r2, published 5/03. Best RISC result on Sun Fire* 280R result of 1008 with 2 UltraSPARC* III Cu processors at 1.2GHz with 8MB L2 cache (off chip), Solaris* 9, Sun ONE Web Server 6.0 SP5, 32GB RAM, published 4/03.
- Source: www.spec.org for Best published RISC result of 96,377 on eServer pSeries IBM 655 using 4 Power4+ 1.7GHz processors, 16GB memory, AIX 5L V5.2 APAR IY43549, JVM J2RE 1.4.1 IBM AIX build cadev-20030410. Itanium® 2 processor 6M result of 116,466 measured by HP on HP Server rx5670 using 4 Itanium® 2 processors 6M at 1.5GHz with integrated 6MB L3 cache, 4GB of memory, HP-UX 11i v2.0, JVM Hotspot 1.4.2.00 and submitted to www.spec.org. SPECjbb* is a trademark of SPEC at www.spec.org.
- Source: Dell Computer for Itanium® 2 processor 6M results on a cluster of 16 Dell PowerEdge Servers, each with 2 Itanium® 2 processors 6M at 1.5GHz, 4GB RAM, RedHat Linux AS 2.1. Source: http://www1.ibm.com/servers/eserver/pseries/hardware/system_perf.pdf for Best RISC result of 143.3GFLOPs on IBM eServer p690 with 32 Power4+ processors at 1.7GHz.
- Source: www.tpc.org: HP Superdome Server, 707,102 tpmC at \$9.13/tpmC, with 64 Intel Itanium 2 processors, each at 1.5 GHz with 6MB of L3 cache, running Microsoft Windows Server 2003 Datacenter Edition and Microsoft SQL Server 2000 Enterprise Edition 64-bit, with 512 GB RAM. TPC-C Availability date: Oct. 23, 2003. Best single system RISC using IBM eServer pSeries 690 Turbo 7040-681, 680,613 tpmC, \$11.13/tpmC, with thirty two (32) IBM Power4+ processors at 1.7GHz, running IBM AIX 5L V5.2, IBM DB2 UDB 8.1, 512GB RAM, Available: 11/08/2003.

Results as of 6/23/03.

Performance tests and ratings are measured using specific computer systems and/or components and reflect the approximate performance of Intel products as measured by those tests. Any difference in system hardware or software design or configuration may affect actual performance. Buyers should consult other sources of information to evaluate the performance of systems or components they are considering purchasing. For more information on performance tests and on the performance of Intel products, reference www.intel.com/procs/perf/limits.htm or call (U.S.) 1-800-628-8686 or 1-916-356-3104



Itanium® 2 Processor 6M at 1.5GHz:

Delivering on the promise of 30-50% performance improvement over
Itanium® 2 Processor 1GHz

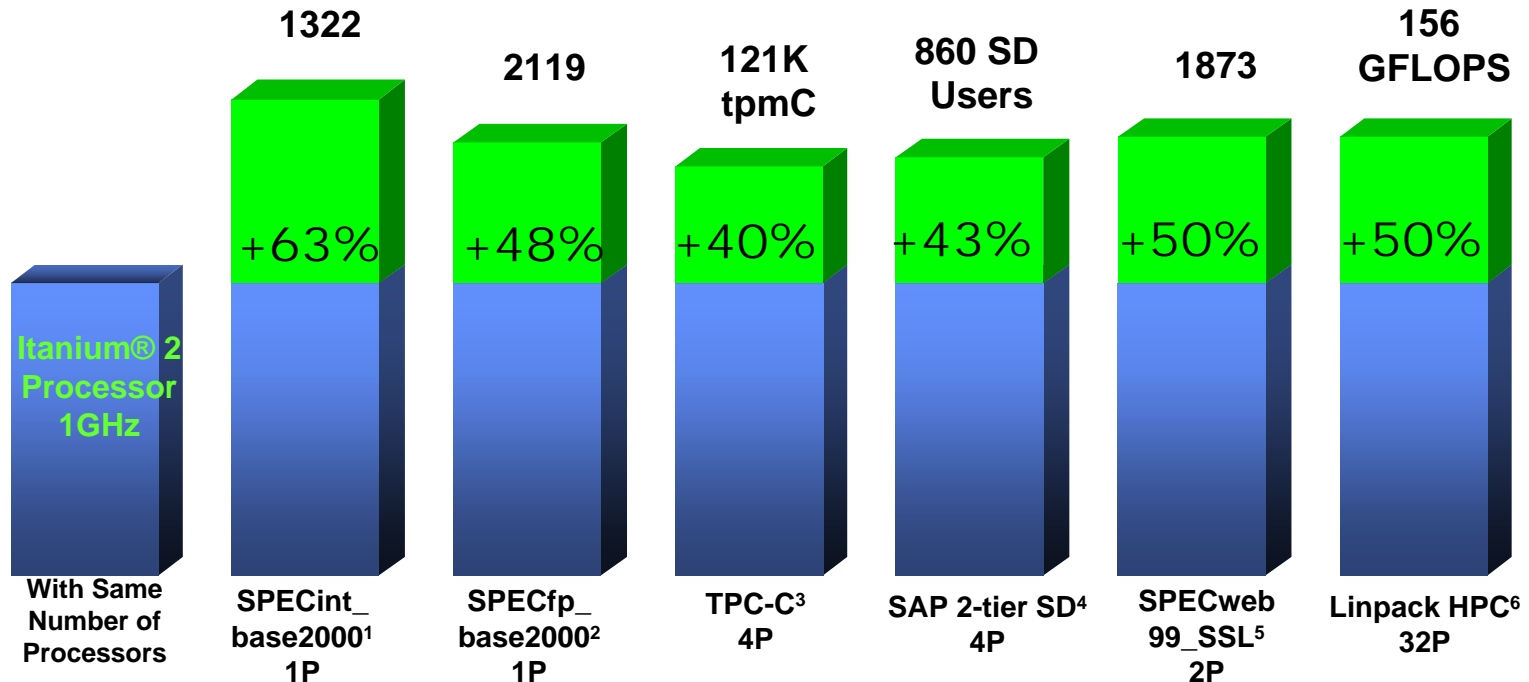

- 1 Source www.spec.org : Itanium® 2 processor 6M results measured on HP Server rx2600 using Itanium® 2 processor 6M at 1.5GHz, HP-UX operating system and submitted to SPEC. SPECint* is a trademark of SPEC*. Itanium® 2 processor result of 810 measured on HP Server rx2600 using Itanium® 2 processor 1GHz with integrated 3MB L3 cache, HP-UX operating system.
- 2 Source www.spec.org : Itanium® 2 processor 6M results measured on HP Server rx2600 using Itanium® 2 processor 6M at 1.5GHz, RedHat Linux AS2.1 operating system and submitted to SPEC. SPECfp* is a trademark of SPEC*. Itanium® 2 processor result of 1431 on HP Server rx5670 using Itanium® 2 processor 1GHz with 3MB L3 cache, RedHat Linux 2.1.
- 3 Source www.tpc.org. Itanium® 2 processor 6M results of 121,065 tpmC and \$4.97/tpmC on HP Server rx5670 using 4 Itanium® 2 processors 1.5GHz with 6MB L3 cache, 64GB memory, Microsoft Windows Server 2003 Enterprise Edition and Microsoft SQL Server 2000 Enterprise Edition 64-bit, availability date 8/1/03. Itanium® 2 processor results on HP server rx5670, 87,741 tpmC at \$5.03/tpmC, with 4 Itanium® 2 processors at 1GHz with 3MB L3 cache, Microsoft Windows .NET Advanced Server, Microsoft SQL* Server 2000 Enterprise Edition 64-bit, 48GB memory, availability date 2/12/03.
- 4 Source: www.sap.com/benchmark. Itanium® 2 processor 6M result measured on HP Server rx5670 using 4 Itanium® 2 processors 1.5GHz with integrated 6MB L3 cache, 24GB of memory, HP-UX 11i, SAP rev 4.6 C, Oracle 9i. Itanium® 2 processor result of 600 SD users on HP Server rx5670 using 4 Itanium® 2 processors 1GHz with 3MB L3 cache, 16GB memory, Windows Advanced Server LE 1.2, SAP rev 4.6 C, SQL Server Enterprise Edition 64bit.
- 5 Source: www.spec.org. Itanium® 2 processor 6M result of 1873 on HP Server rx2600 using 2 Itanium® 2 processors 1.5GHz with 6MB L3 cache, 12GB memory, HP-UX, Zeus 4.2r2, published 5/03. Itanium® 2 processors result of 1230 on HP Server rx2600 using 2 Itanium® 2 processors 1GHz with 3MB L3 cache, 8GB memory, HP-UX, availability 9/02.
- 6 Source: Dell Computer for Itanium® 2 processor 6M results on a cluster of 16 Dell PowerEdge Servers, each with 2 Itanium® 2 processors 6M at 1.5GHz, 4GB RAM, RedHat Linux AS 2.1. Itanium® 2 processor measurement of 101.77GFLOPs done on a NEC Server TX7/9510 using 32 Itanium® 2 processors 1GHz with integrated 3MB L3 cache, 128GB memory, Linux OS.

Results as of 6/23/03.

Performance tests and ratings are measured using specific computer systems and/or components and reflect the approximate performance of Intel products as measured by those tests. Any difference in system hardware or software design or configuration may affect actual performance. Buyers should consult other sources of information to evaluate the performance of systems or components they are considering purchasing. For more information on performance tests and on the performance of Intel products, reference www.intel.com/procs/perf/limits.htm or call (U.S.) 1-800-628-8686 or 1-916-356-3104

Low Voltage Itanium® 2 Processor

- Extension of the Itanium® processor family
 - 1.0 GHz, 1.5 MB L3 cache, DP/UP only
 - 62W maximum power, over 50% lower than Itanium® 2 processor 6M
 - Compatible with Itanium® 2-based DP platforms
- Target market
 - Entry 64-bit servers and performance workstations
 - High density form factors benefit from lower power
 - Application segments including security, application development network edge and HPC
- Schedule
 - Platform release target: Q3 2003

Floating Point
SPECfp_base2000

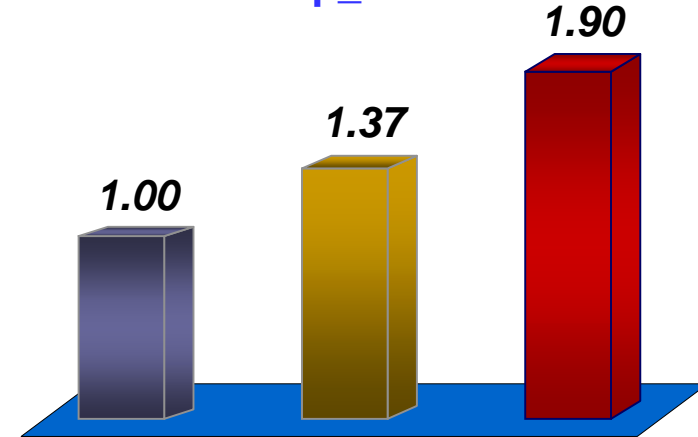

Integer
SPECint_base2000

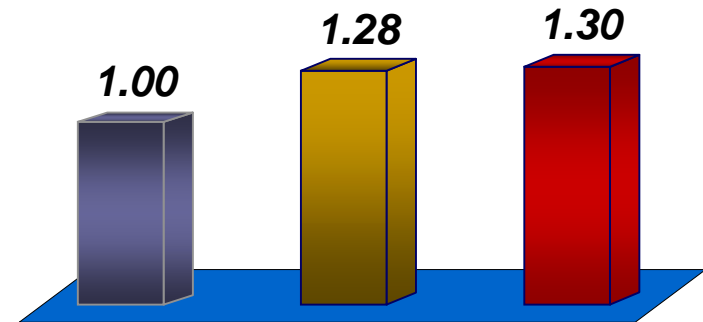

Sun* Ultra-SPARC* III Cu	Alpha* 21364C	LV Itanium® 2 (Deerfield)
1.05GHz	1.0GHz	1.0GHz
8M (off-die)	1.75M	1.5M

Performance similar to Itanium® 2 processor 1.0GHz at about half the power

Intel 2 and 4-way System Configurations



	SR870BN4 (Tiger-4)	SR870BH2 (Tiger-2)
Rack Units	4U	2U
Processor	Intel® Itanium® 2 processor	
Chipset	Intel® E8870	
Memory Capacity	32GB in 16 DIMMs	16GB in 8 DIMMs
PCI Slots	8 PCI-X 3 @ 133 MHz 5 @ 100 MHz	3 PCI-X 1 @ 133 MHz 2 @ 100 MHz
HDD Capacity	3 HDDs, 220GB	2 HDDs, 145GB
On-board Ethernet	Single Kenai32	Dual Anvik
Graphics	ATI* Rage* XL VGA	ATI* Rage* XL VGA
Cooling	(4) fans = (2) 1" + (2) 1.5" redundant & hotswap	(6) fans redundant & hotswap
Power	(2) 1200W TPS, hot-swap 1+1 redundant	(3) 350W TPS, hot swap 2+1 redundant

Madison 9M Key Features

- Itanium® 2 platform compatibility
- Socket and system bus compatible
- Shares the same chip set
- Binary compatible with Itanium® processor software
- Increase L3 cache size to 9MB on 130nm process
- Increase frequency above 1.5GHz
- Also refresh “DP only” Itanium® 2 processor offerings

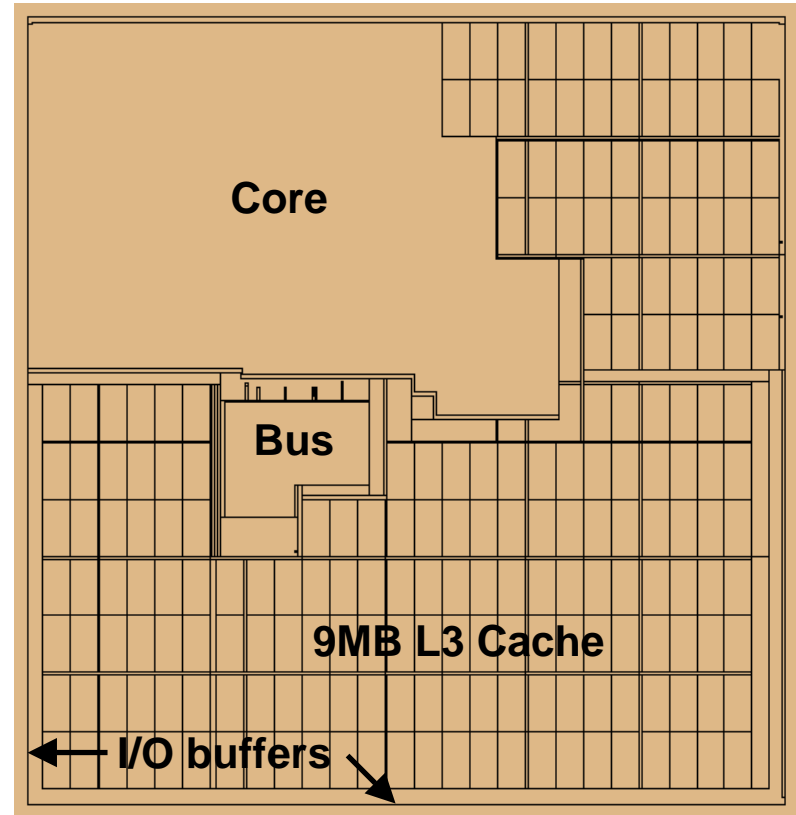

Summary

- **The Itanium[®] 2 Processor 6M (Madison) delivers 2X larger on-die cache and 50% higher frequency**
- **Compatible with today's Itanium[®] 2-based systems**
- **Enterprise-class RAS, DFT and DFM features**
- **Largest on-die cache and transistor count ever reported for a microprocessor**
- **Low Voltage Itanium[®] 2 processor to deliver performance similar to Itanium[®] 2 processor 1.0GHz at about half the power**
- **Itanium roadmap committed to delivering leading performance through innovation**