



TeraOPS Hardware: A New Massively-Parallel MIMD Computing Fabric IC

**Anthony Mark Jones
Mike Butts**



Embedded Computing Problem

Traditional architectures are reaching limits in performance, scalability and ease of development

- Single CPUs and DSPs are reaching limits of extending performance
- Ordinary multi-core processors won't scale very far
- ASICs and high-end FPGAs are getting harder and more costly to develop

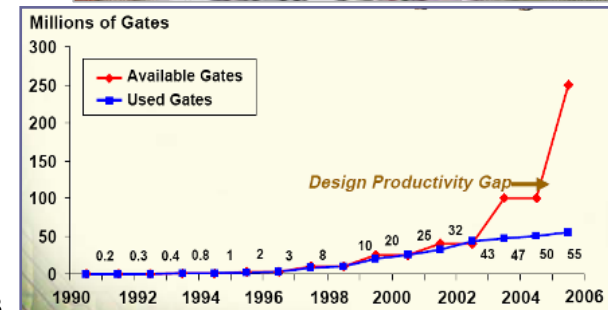

Gary Smith, Gartner Dataquest, DAC 2003

Embedded Synchronous Problem

MPEG2 Decoder example

■ Ordinary globally synchronous system

- Central controller required
- Synchronization is up to the developer
- Local changes break global synchronization
- Difficult to validate
- Not scalable

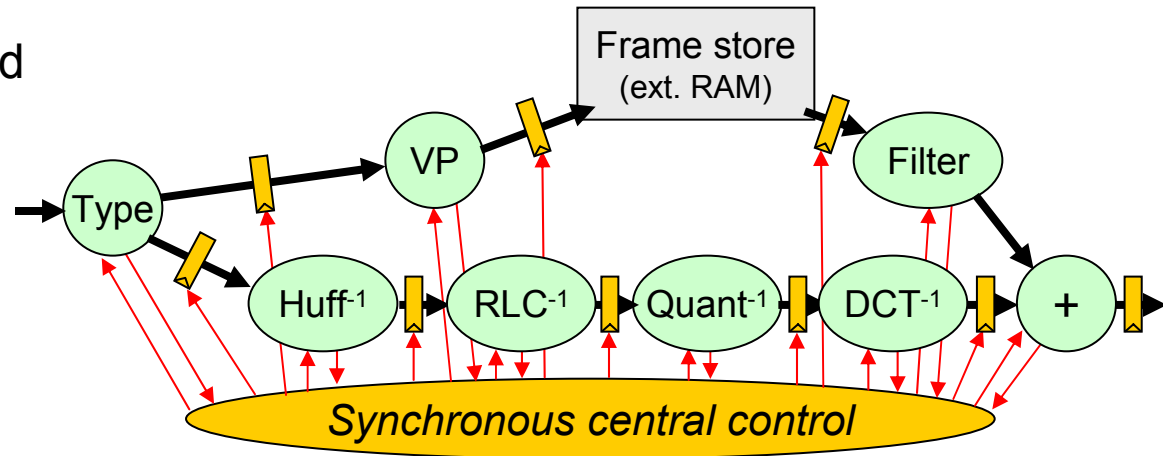

■ Globally asynchronous system of Ambric objects and channels

- Distributed control
- Self-synchronizing
- Local changes have only local effects
- Scalable

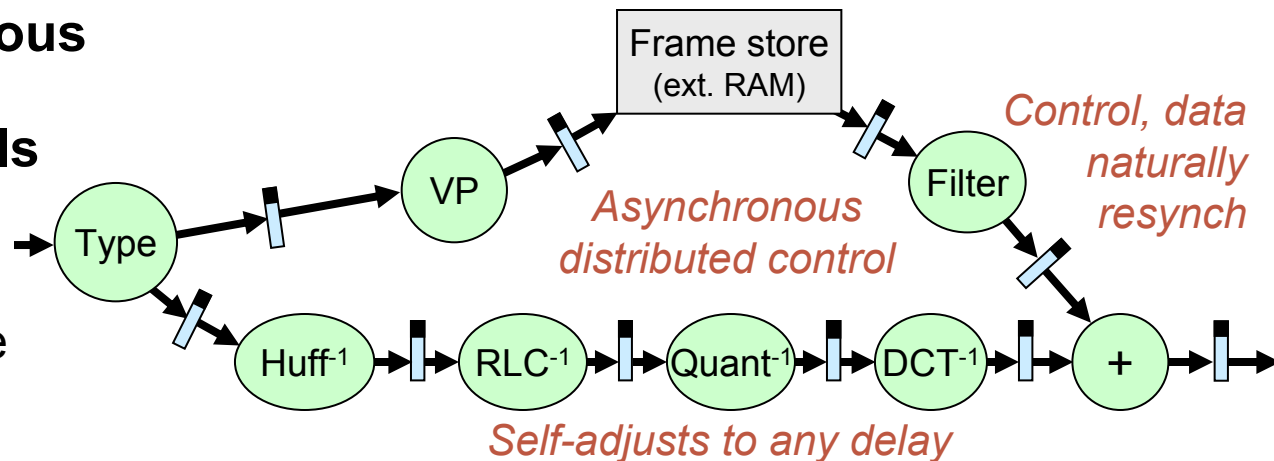

Ambric's Structural Object Programming Model

- Objects are software programs running concurrently on an asynchronous array of Ambric processors and memories
- Objects exchange data and control through a structure of self-synchronizing asynchronous Ambric channels
- Objects are mixed and matched hierarchically to create new objects, snapped together through a simple common interface
- Easier software development, high performance and scalability

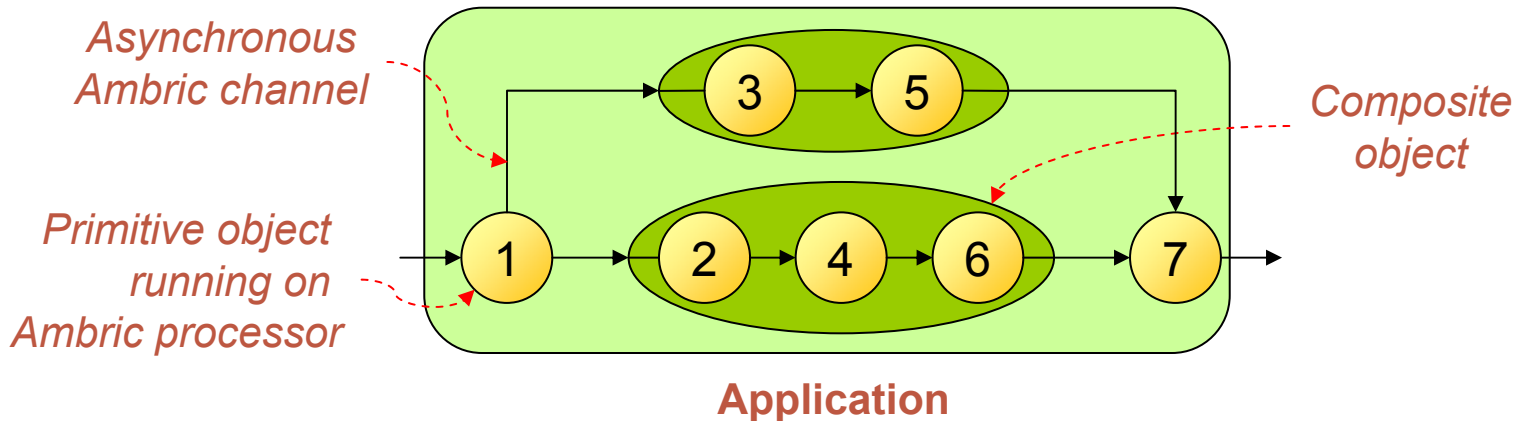

Ambric Registers and Channels

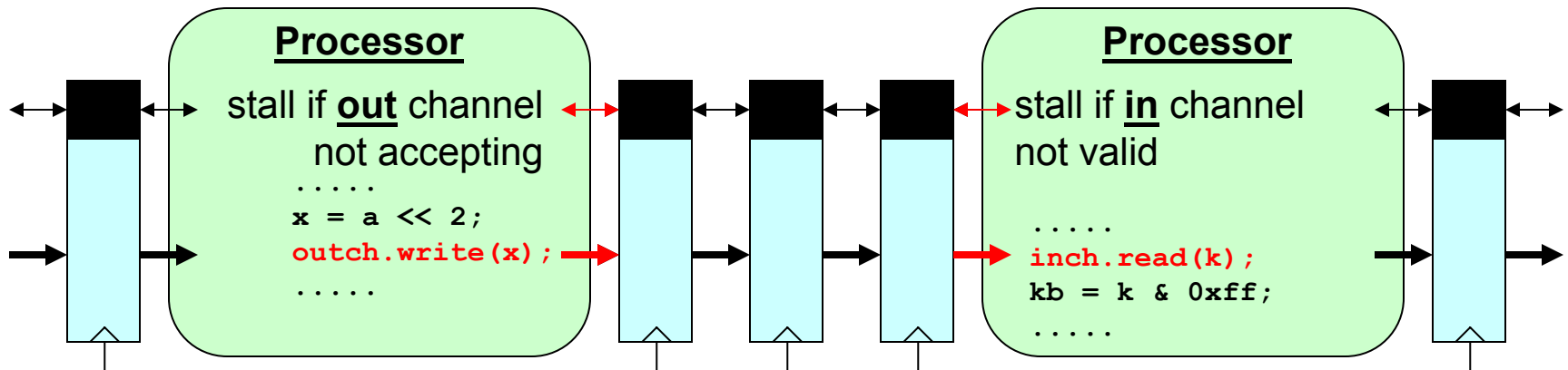

- **Ambric register**
 - Latency, speed, area, power of an ordinary register
 - FIFO buffering, localized forward and back-pressure
- **Chains of Ambric registers form Ambric channels**
 - Fully encapsulated, fully scalable for control and data between objects
- **Ambric processors are interconnected by Ambric channels**
 - Ambric registers permit inputs and outputs to run at different clock rates

Traditional vs. Ambric Processors

■ Traditional processor architecture

- Primary: register-memory hierarchy
- Secondary: communication

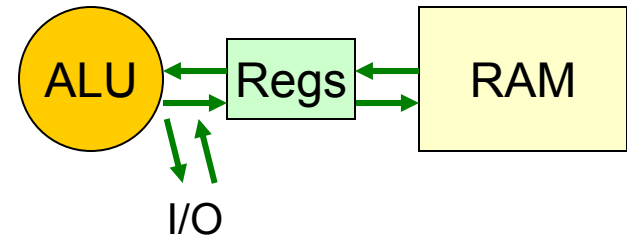

■ Ambric processor architecture

- Primary: communicate through channels
 - All data goes through channels
 - Memory
 - Registers
 - Inter-processor streams
 - Instruction streams
- to reduce local storage
- Channels synchronize all events
 - ELIO: Execute/Loop/Input/Output every cycle

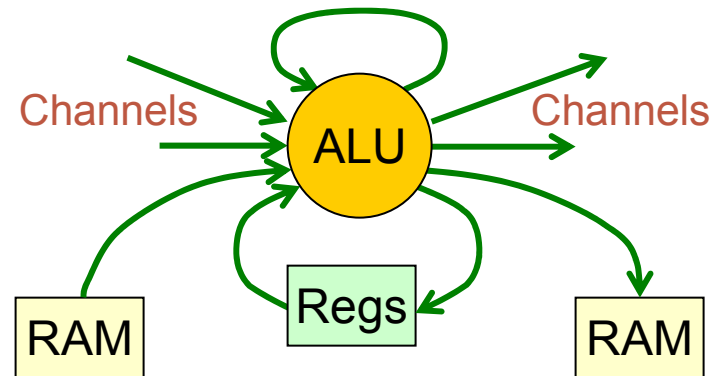

Compute Unit, RAM Unit

Compute Unit (CU)

- SRD 32-bit CPU
 - Streaming RISC with DSP extensions
 - 3 ALUs: 32b, 2x16b, 4x8b
 - 256 word local RAM
- SR 32-bit CPU
 - Streaming RISC
 - 1 ALU : 32b, 2x16b
 - 64 word local RAM
- 32-bit Ambric channel interconnect
 - Processor-Processor
 - CU-Neighbor
 - CU-Distant

RAM Unit (RU)

- Four 1KB RAM banks
- RU engines
 - RAMs, FIFOs, etc.

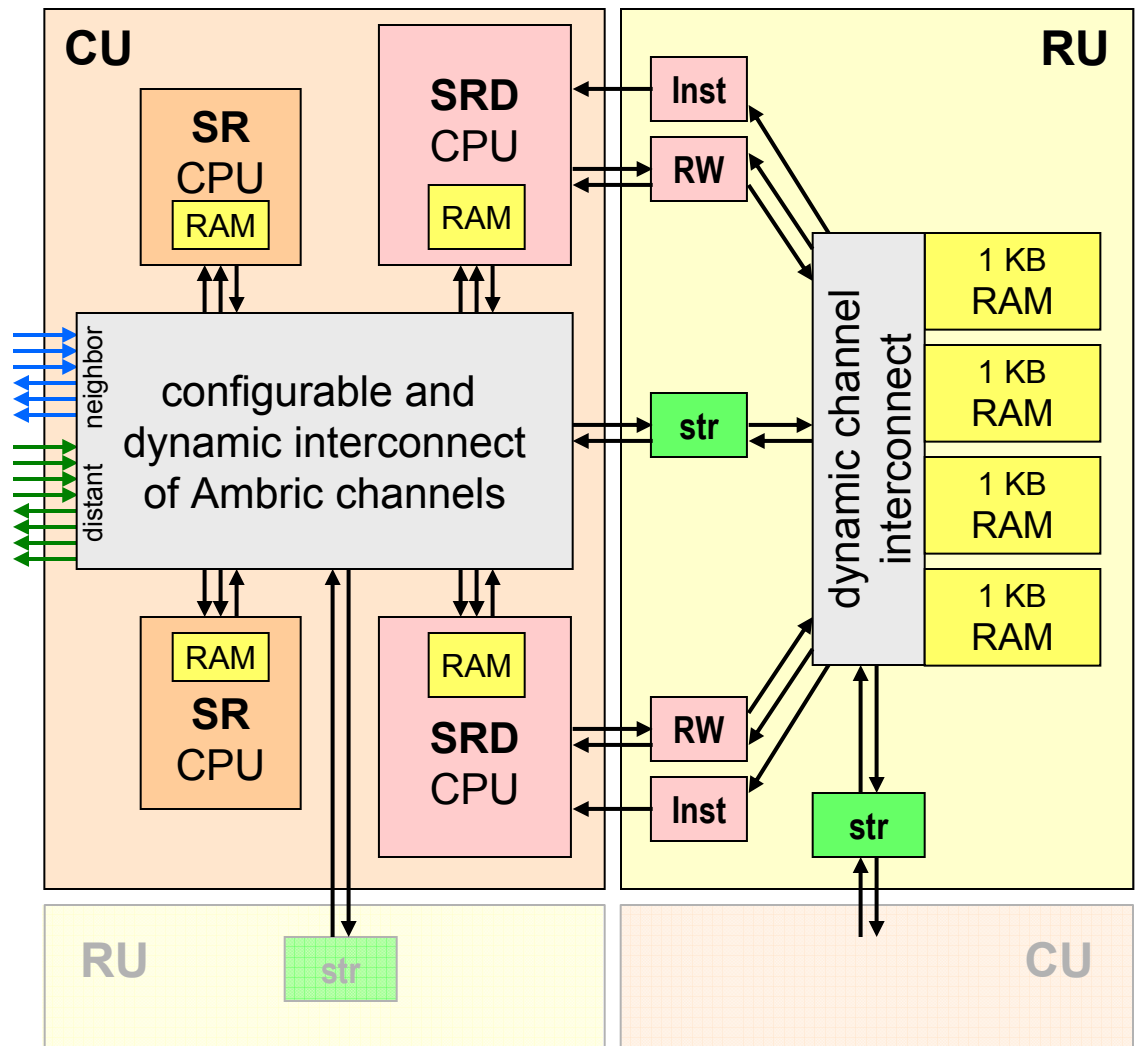

→ = Ambric channel

Brics and Interconnect

- The brick is the physical building-block
 - Two CU-RU pairs
 - 8 CPUs
 - 13KB RAM
- Brics connect by abutment to form a core array
 - CU quads, RU quads
- Neighbor CU channels
- Distant CU channels:
 - bric-length hops
 - configurable switches
- No wires longer than a bric

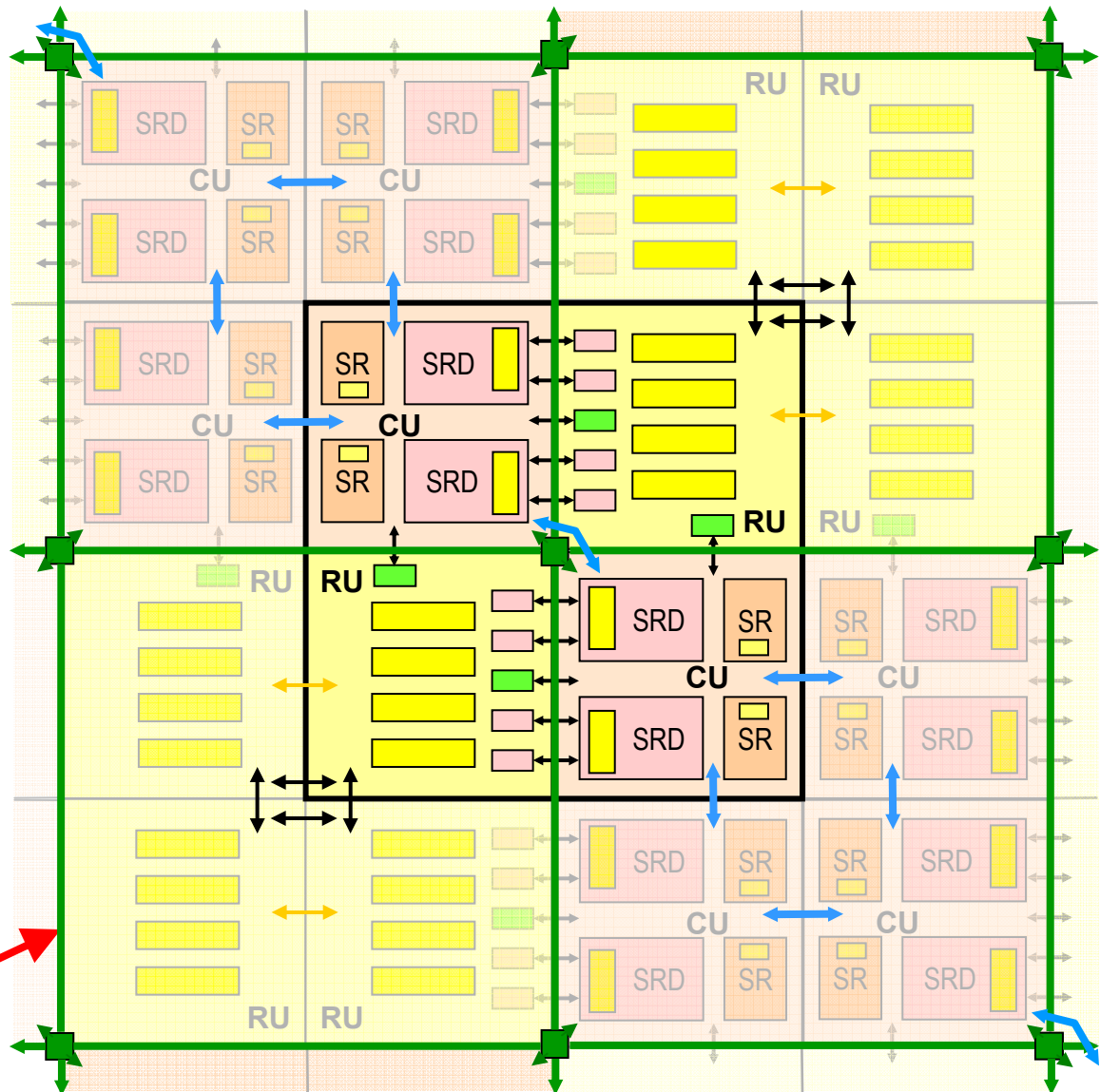

Programming Model and Tools

- **Structure**
 - Conceive your application as a structure of objects and the messages they exchange when running
 - Divide-and-conquer using hierarchy
- **Reuse**
 - Validated, encapsulated library objects
- **Code and test**
 - Write your application-specific objects and compile
 - Verify with functional simulation
- **Realize**
 - Run mapper-router and configure chip
- **Run and Visualize**
 - Observe and control objects and messages using dedicated debug HW

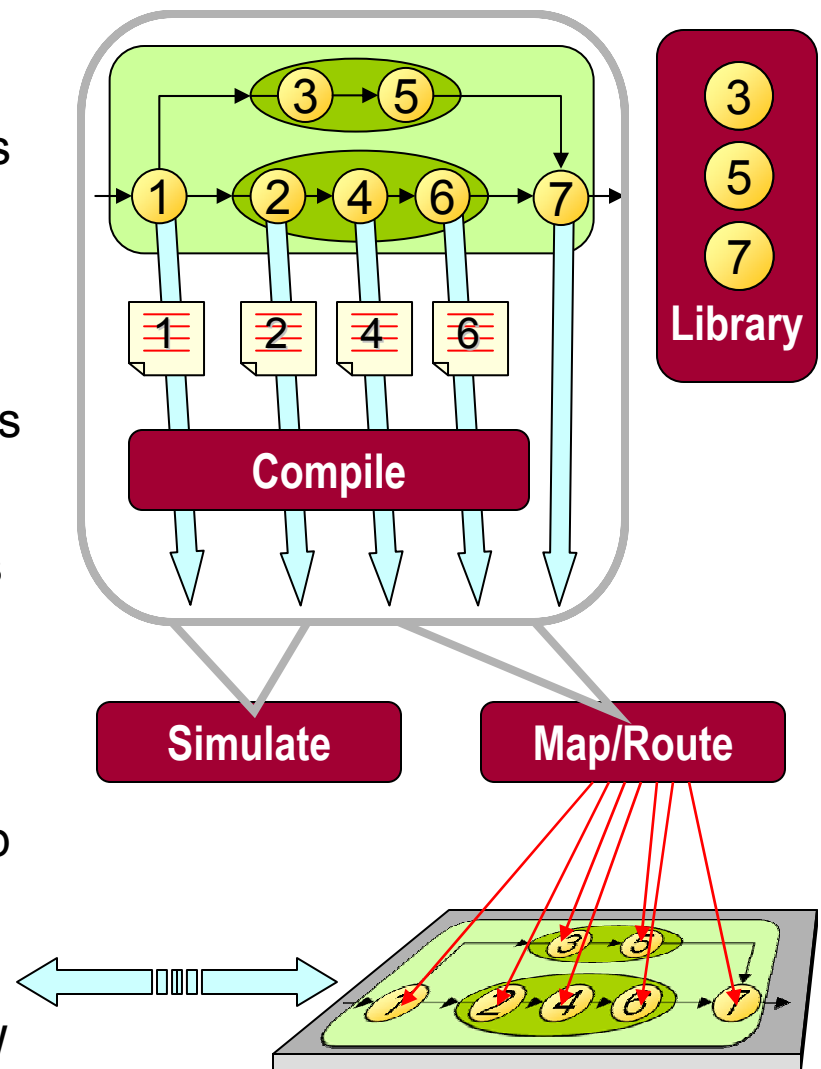

Performance Metrics

- **Prototype chip @ 45 brics:**
 - 1.08 trillion operations per second (24 BOPS per bric)
 - 425 Gbps interconnect bi-section bandwidth
 - 26 Gbps DRAM + 16 Gbps high-speed serial + 13 Gbps parallel

	Ambric 45-bric Prototype	Ambric 70-bric Example	TI C641x DSP	Xilinx Virtex-4 LX100 - LX200
Process	130nm	90nm	90nm	90nm
MHz	333 MHz	Est. 450 MHz	1,000 MHz	500 MHz
Published DSP Benchmarks	10-25X throughput, 1/3 the code	Est. 20-50X throughput, 1/3 the code	1X	n/a
Multiply-Accum./Sec. (16x16 – 32-bit)	60 GMACS	Est. 125 GMACS	4 GMACS	48 GMACS

Application Example: Motion Estimation

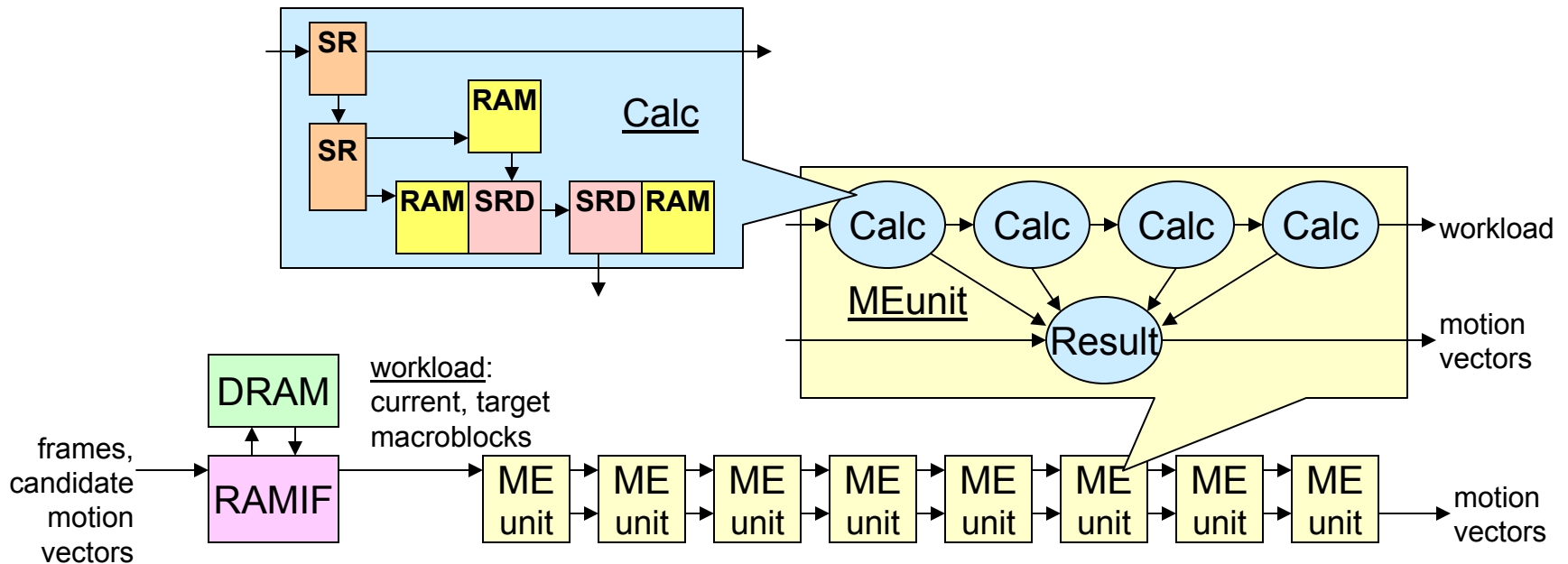

- Perform SAD calculation for 16x16 macroblocks, choose best results
 - Exhaustively over +/-16 pixel range, centered on *any* candidate vector
 - For 720p (1280x720) @ 60 frames/sec, two reference frames
- Actual performance using 89% brics @ 300 MHz: 0.46 teraOPS
 - 53% of maximum teraOPS available

Intrinsically scalable to 65nm and beyond

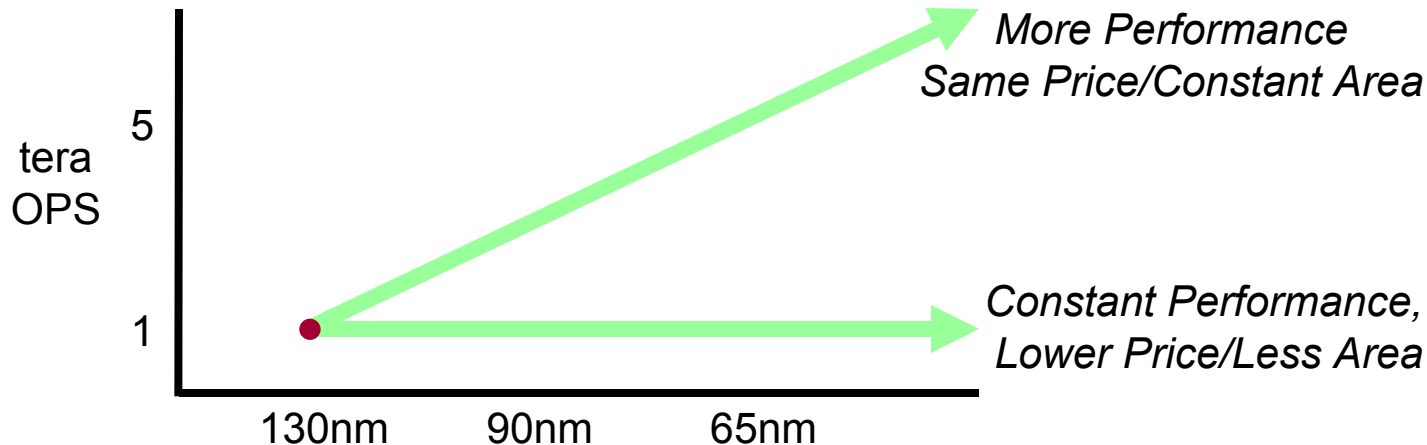

- Hierarchical Object-Based Modularity for Development Cost
 - Massive design reuse requires strict encapsulation, simple identification of dependencies and local synchronization
- Communication-Centric Design for Timing Scalability
 - Globally asynchronous, locally synchronous (GALS)
- Massive Parallelism for Power Scalability
 - MIMD architecture: power scales linearly with performance

Other Massively-Parallel Architectures

- **Ambric architecture is a member of an emerging class: *Reconfigurable Processing Array (RPA)***

- Hundreds of processing elements such as CPUs, ALUs, memories...
- Rich, word-wide, reconfigurable interconnect fabric
- **SIMD control** or **MIMD control**

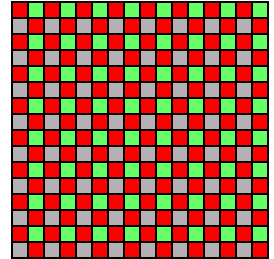

- **MIMD is more general than SIMD**

- MIMD is effective on irregular complex apps (H.264)
- Efficient on other data structures than just vectors
- Processors stay busy on different size data sets
- Processors do not have to branch in lock-step

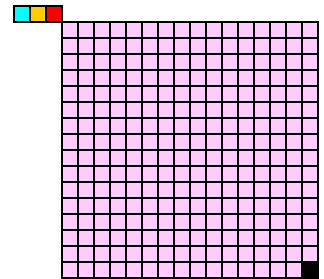

- **Ambric's MIMD RPA is practical**

- Interconnect is dynamically self-scheduling
- Based on an asynchronous parallel model of computation
- Standard high-level language (strict subset) or assembly
- Globally asynchronous: efficient and scalable

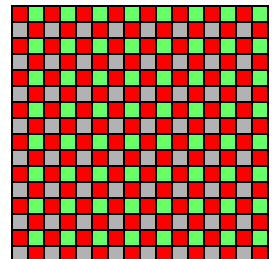

'Kestrel' Prototype IC

- 130nm general-purpose Cu-FSG std-cell digital process
- 117 million transistors
- All standard cells in the array
- 85% cell-density in the array
- 333 MHz
- ~ 1/3 the area of a large 90nm FPGA

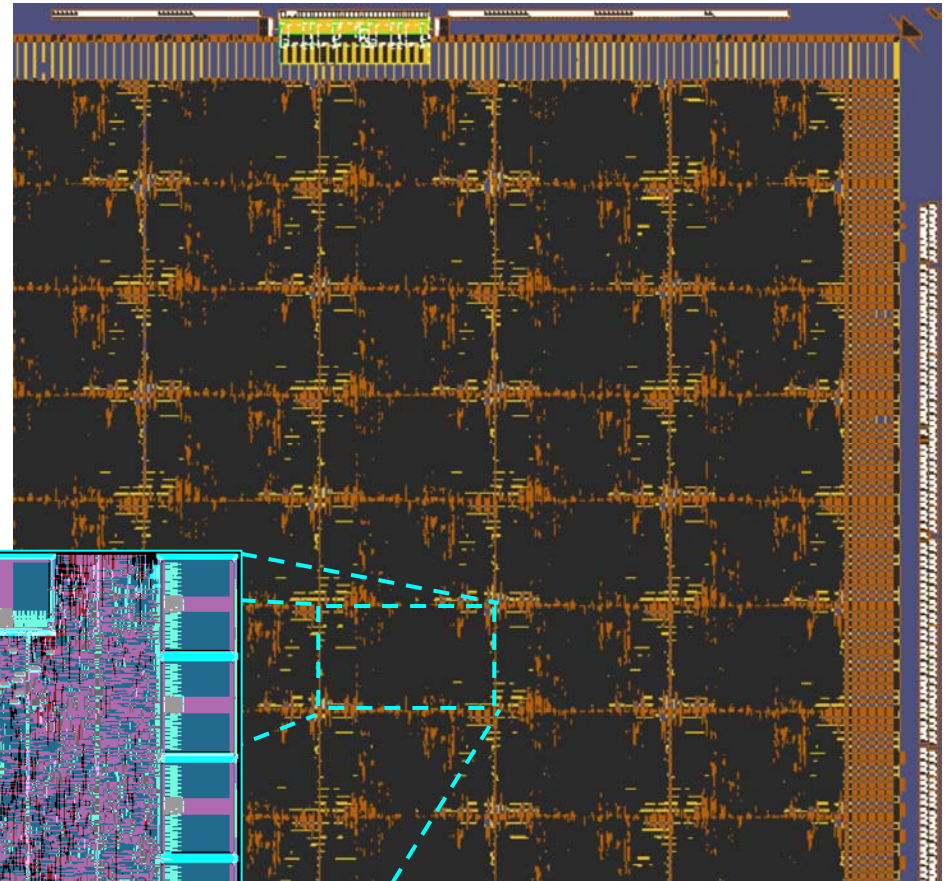

Summary

- Ambric has solved many of the architectural and programming challenges of massively-parallel embedded computing
- Ambric's chip and tools realize a Structural Object Programming Model for ease of development
- Ambric chip and tools deliver 10X+ performance over traditional alternatives for high-performance embedded computing
- Ambric's architecture economically scales with Moore's Law

Patents pending