



Integrated Inductors with Magnetic Materials for On-Chip Power Conversion

Donald S. Gardner

*Collaborators: Gerhard Schrom, Fabrice Paillet,
Tanay Karnik, Shekhar Borkar*

**Circuits Research Lab &
Future Technology Research**

Intel Labs

Intel Corporation

Outline

- **DC Voltage Converters**
 - Comparison of buck converters
 - Comparison of inductors with magnetic films
- **Magnetic material properties**
 - Magnetic hysteresis loops
 - Complex permeability spectra
- **Inductors**
 - Structure cross sections
 - Inductance measurements
 - Eddy current and skin effect
 - Sheet and shunt inductance

Multi-Core Power Management

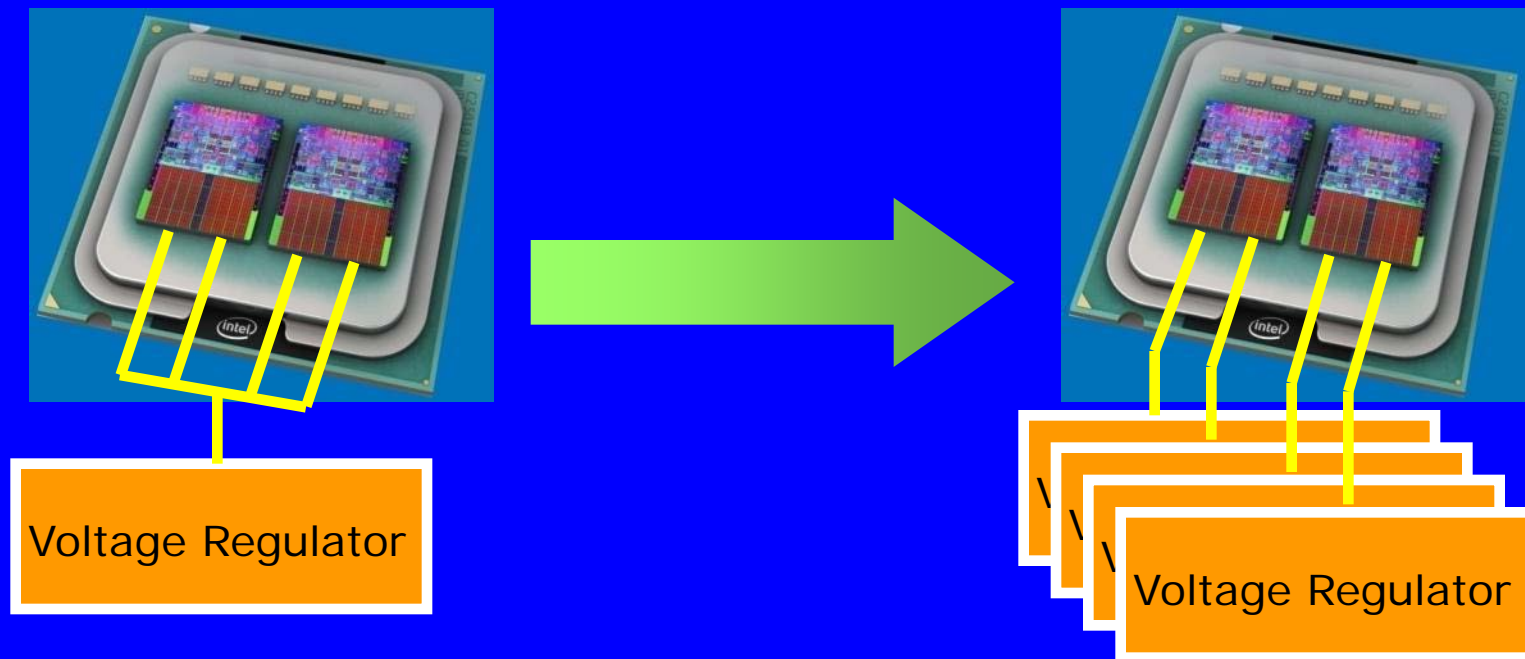

- **Today - Coarse Grain Power Management**
 - same voltage to all the cores, variable voltage
- **Future – Fine Grain Power Management**
 - each core or cluster of cores operates at the optimum voltage

Two-Phase Buck Converter with Coupled Inductors

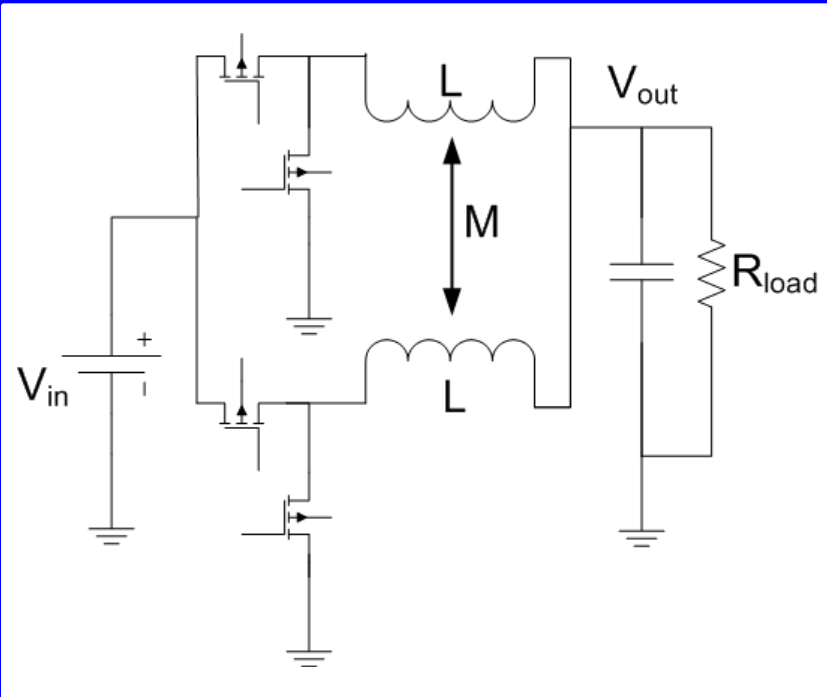

Inductor Power Losses

DC loss component

AC loss component

$$P_{LOSS} = R_{DC} \times I_{Lavg}^2 + R_{AC} \times \frac{\Delta I_{p-p}^2}{12} + P_{hys}$$

Load dependent

Frequency dependent

$$\Delta I_{p-p} = \frac{(1-D)V_{out}}{f_s L_{eff}}$$

$D = \text{duty cycle}$

$f_s = \text{frequency}$

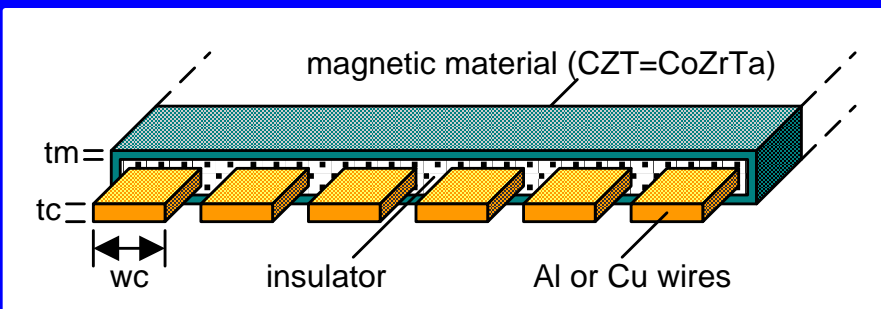

100~480 MHz Switching Regulator

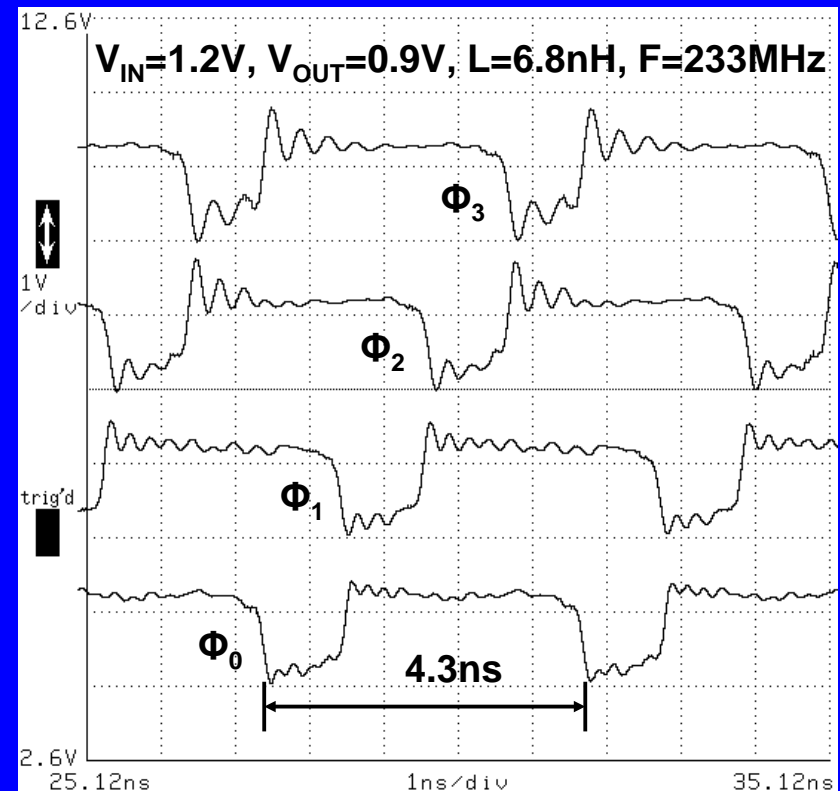
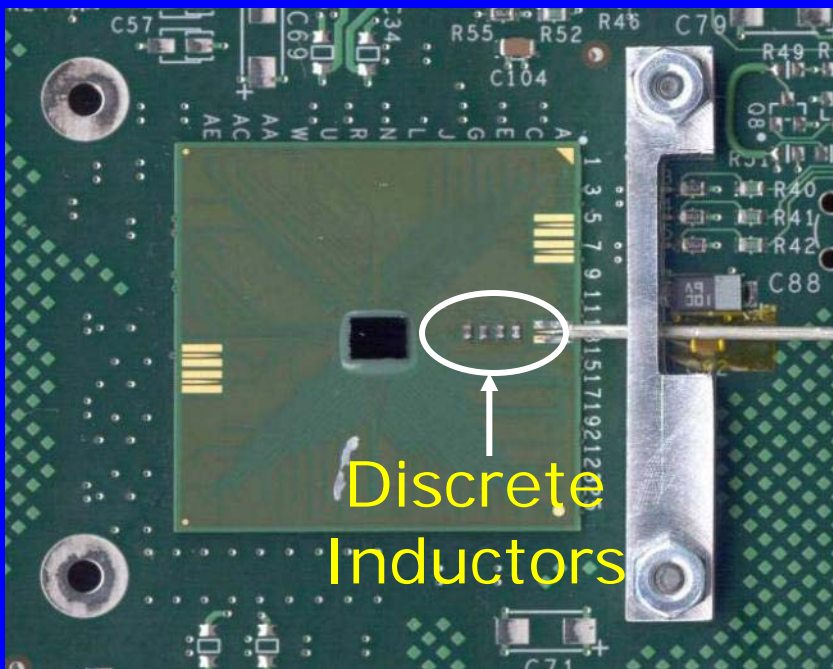

- High frequency
- Hysteretic multi-phase topology 1ns response
- 88% efficiency

Schrom, Gardner, et.al., IEEE PESC 2004 and IEEE VLSI Symp. 2004.

Comparison of DC Converters

	[3]	[4]	[5]	[6]	[7]	Pavo-1
Year	1996	1999	2000	2002	2002	2004
Tech [μm]	n/a	0.25	n/a	0.25	n/a	0.09
# phases	1	1	1	1	1	4
V_{IN} [V]	4	3	4	2.5	3.6	1.2
V_{OUT} [V]	3.3	2	3	1.4	2.7	0.9
f [MHz]	1.6	0.5	3	0.75	1.8	233
Eff. [%]	85	94	83.3	95	80	83.2
L_{TOT} [μH]	3	10	1	15.2	1	0.0017
C [μF]	n/a	47	1	21.6	n/a	0.0025
I_{MAX} [A]	0.3	0.25	0.33	0.25	0.3	0.3
Area [mm^2]	n/a	0.46	20	0.35	n/a	0.14

100x
higher f

1000x
Smaller
L and C

Package-Integrated VR with Intel® Core™2 Duo Processor

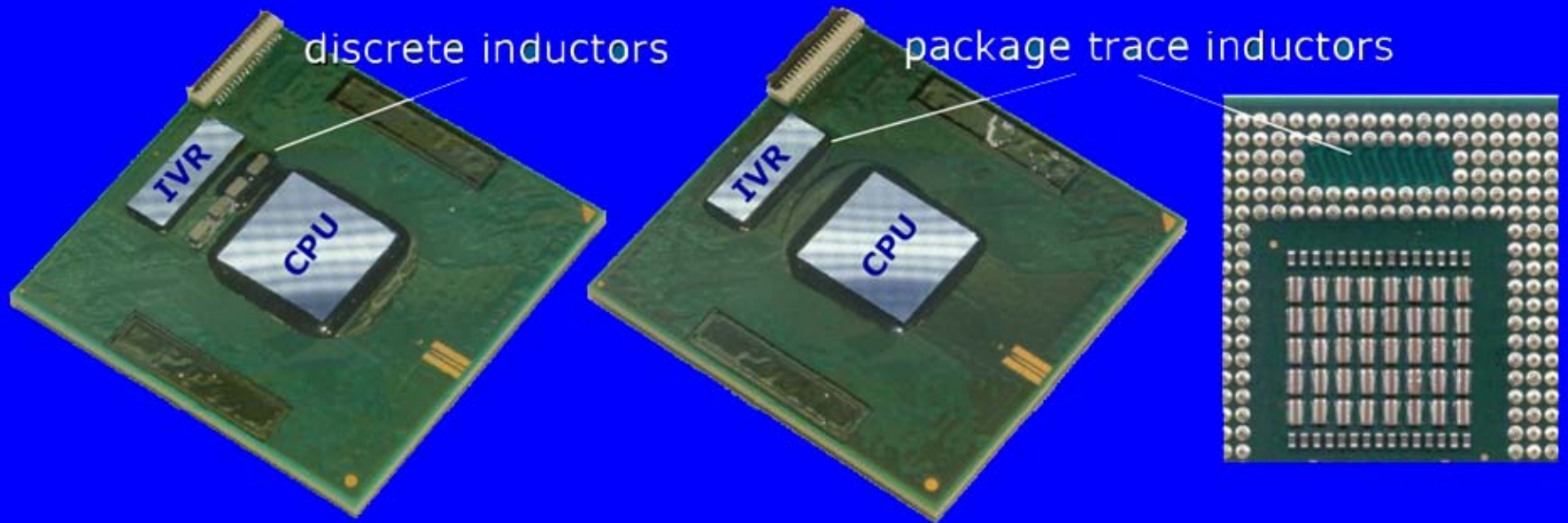

- $V_{in} = 3V$, $V_{out} = 0\sim 1.6V$
- $f = 10\sim 100$ MHz
- Current = 50 Amps / 75 Amps peak
- Size = 37.6 mm², 130 nm CMOS

Efficiency Measurements

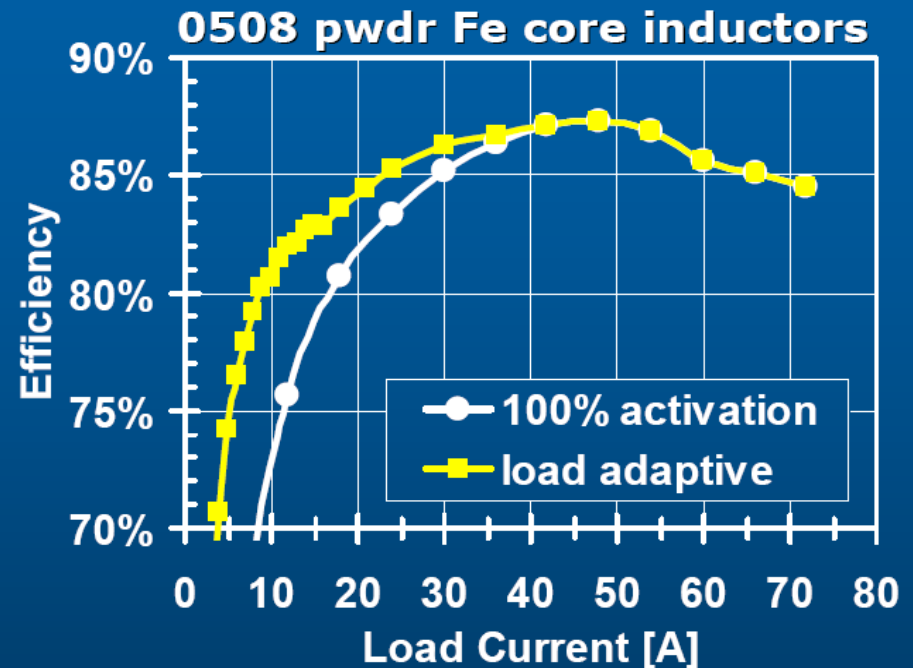
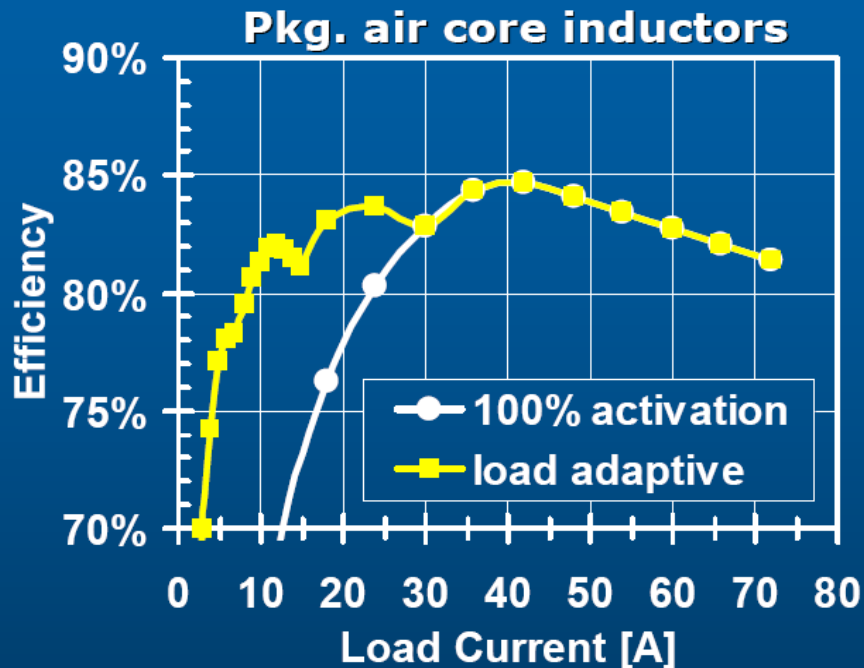

- Package embedded air core inductors: 84.9%
- Discrete powdered Fe core inductors: 87.9%
- Load adaptive bridge activation improved by >10%

RF CMOS Integrated Circuit

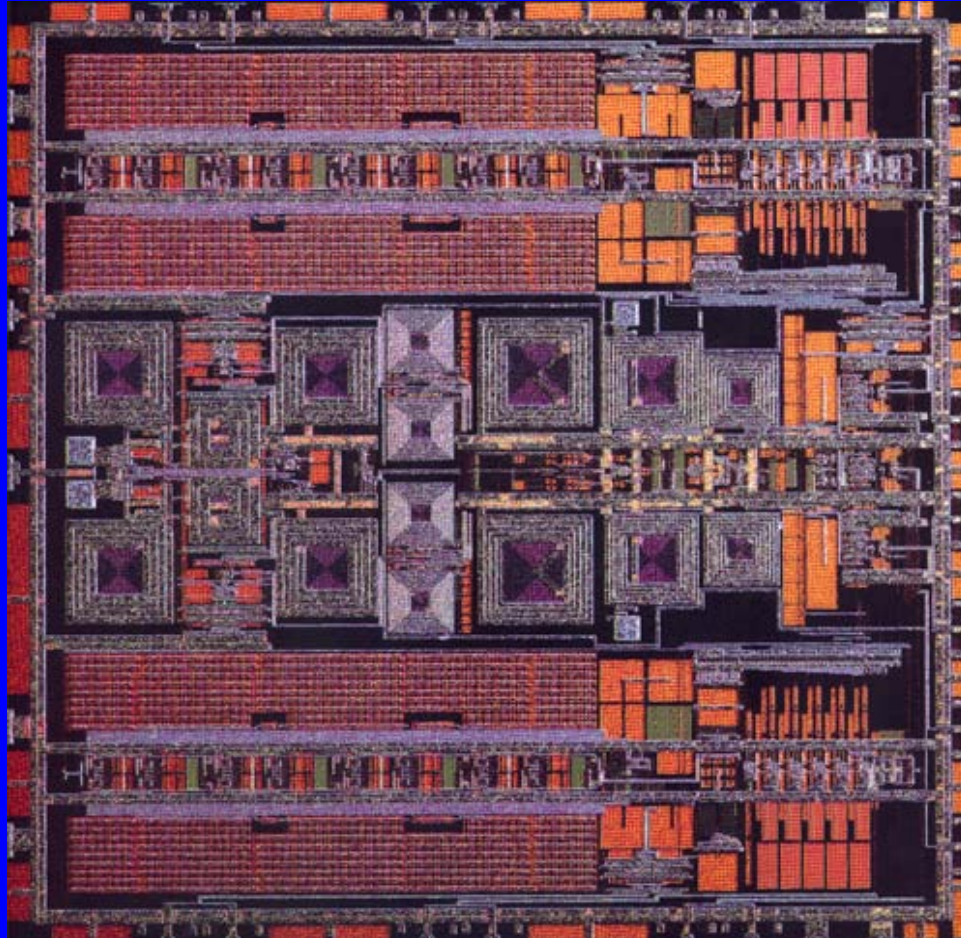

Inductors make up 24% of this chip

Inductance density of spirals is small (<100 nH/mm²)

Inductance Densities vs. Q-Factor from the Literature

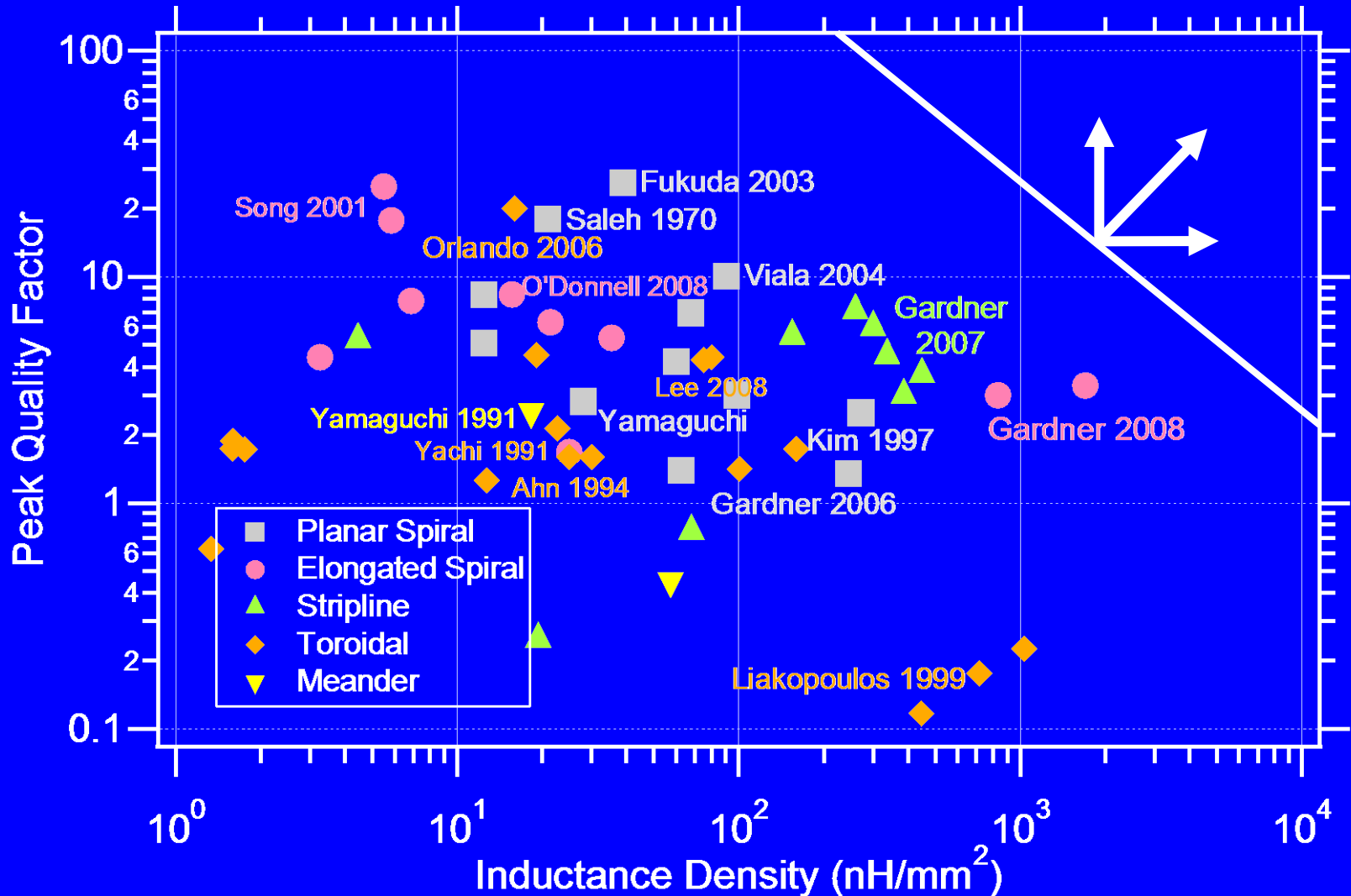

Magnetic Hysteresis Loops for CoZrTa & NiFe

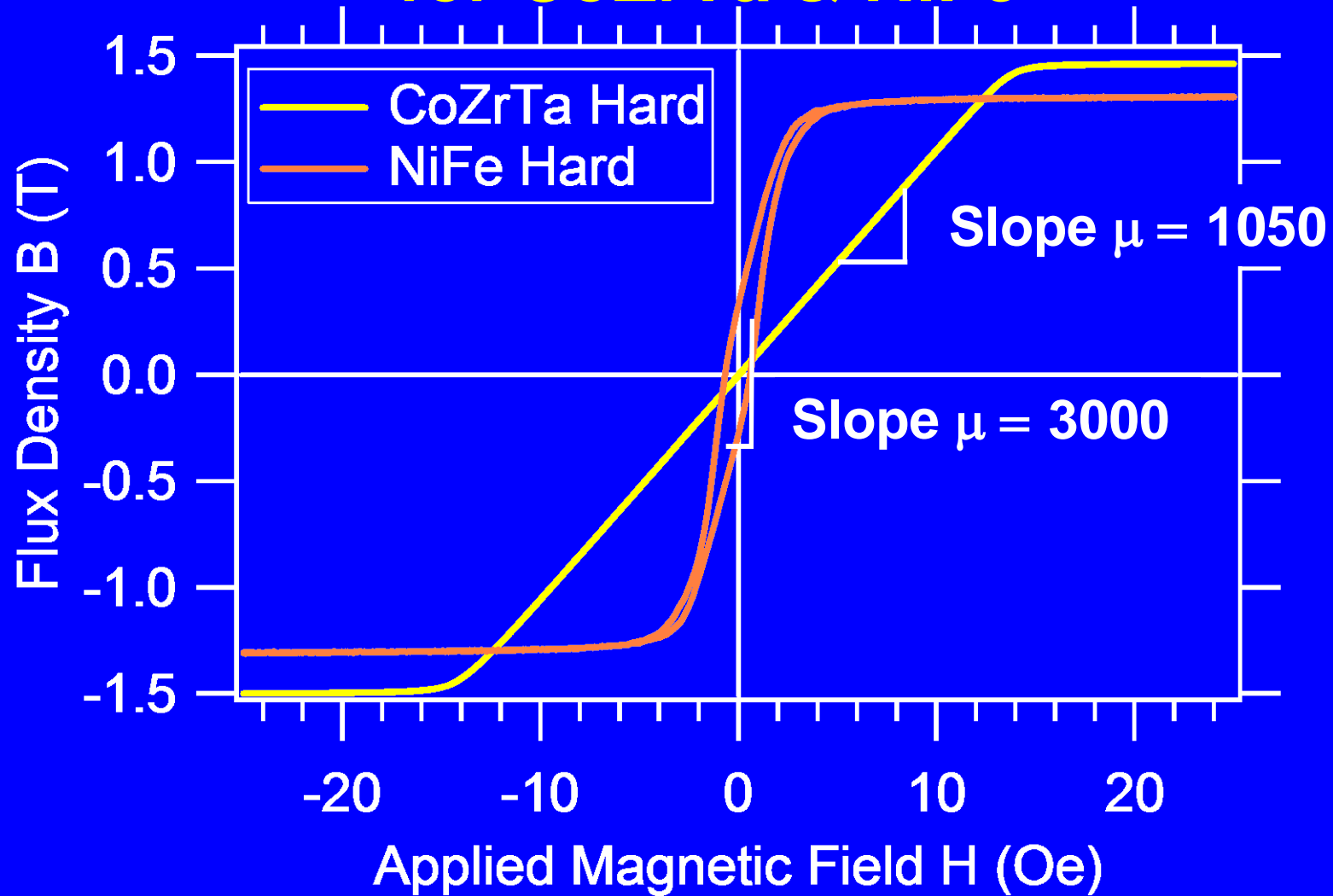

Permeability vs. Applied Magnetic Field

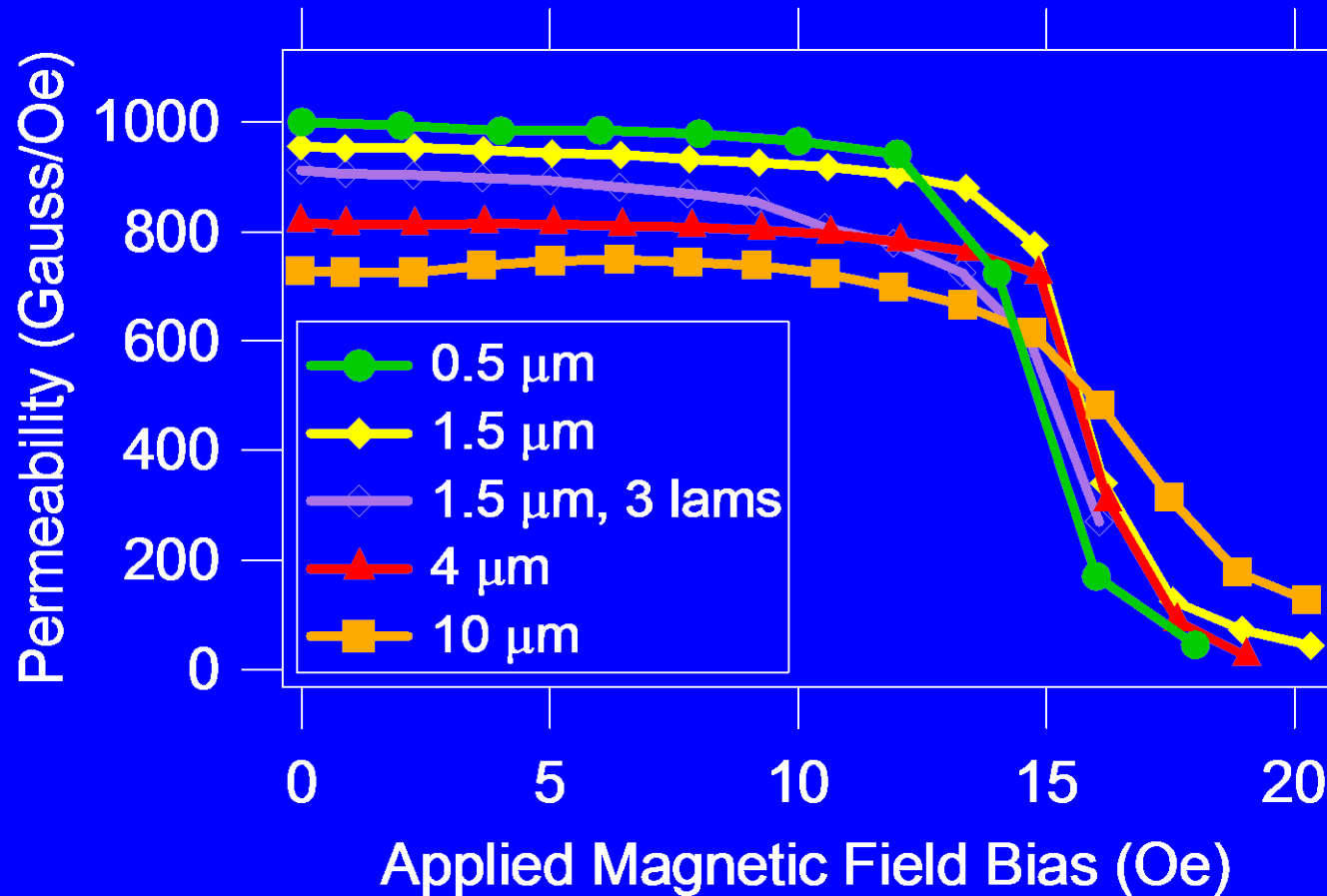

Magnetic anisotropy H_k has two components:

- The intrinsic induced anisotropy from the deposition
- The demagnetizing energy caused by the sample shape

Complex Permeability Model

$$\delta = \sqrt{\frac{2\rho}{\omega\mu_i\mu_o}}$$

δ = skin depth

ρ = resistivity of magnetic film

ω = frequency

μ_i = relative dc permeability

d = film thickness

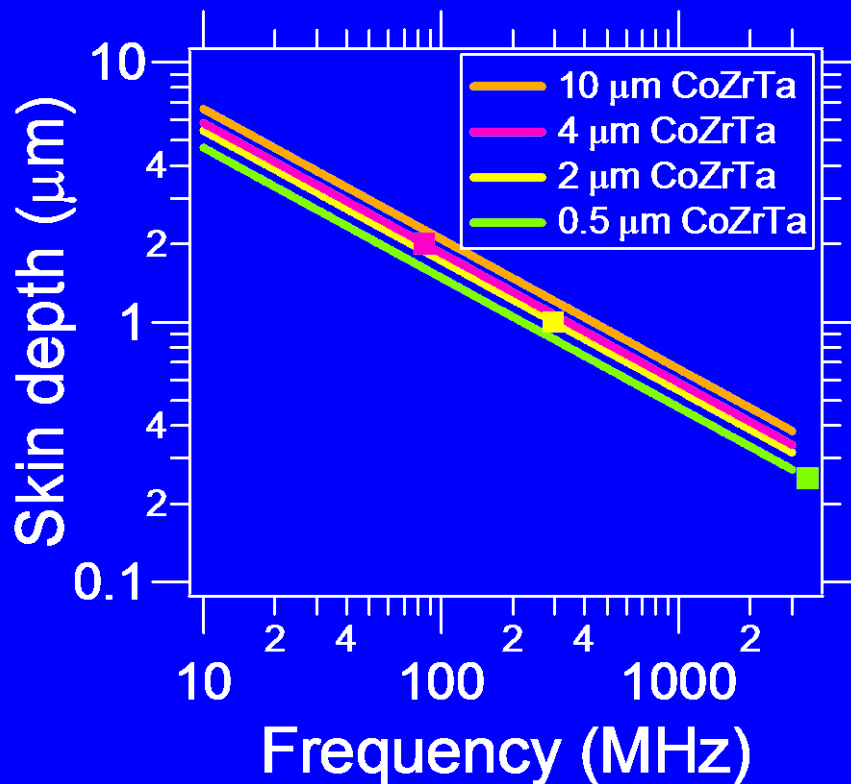

$$\mu = \mu_i \frac{2\delta}{(1+j)d} \tanh \frac{(1+j)d}{2\delta}$$

High resistivity materials are needed to reduce the eddy currents and increase the skin depth.

CoZrTa \rightarrow $\rho = 100 \mu\Omega\text{-cm}$

Permeability Spectra of CoZrTa

Real Component

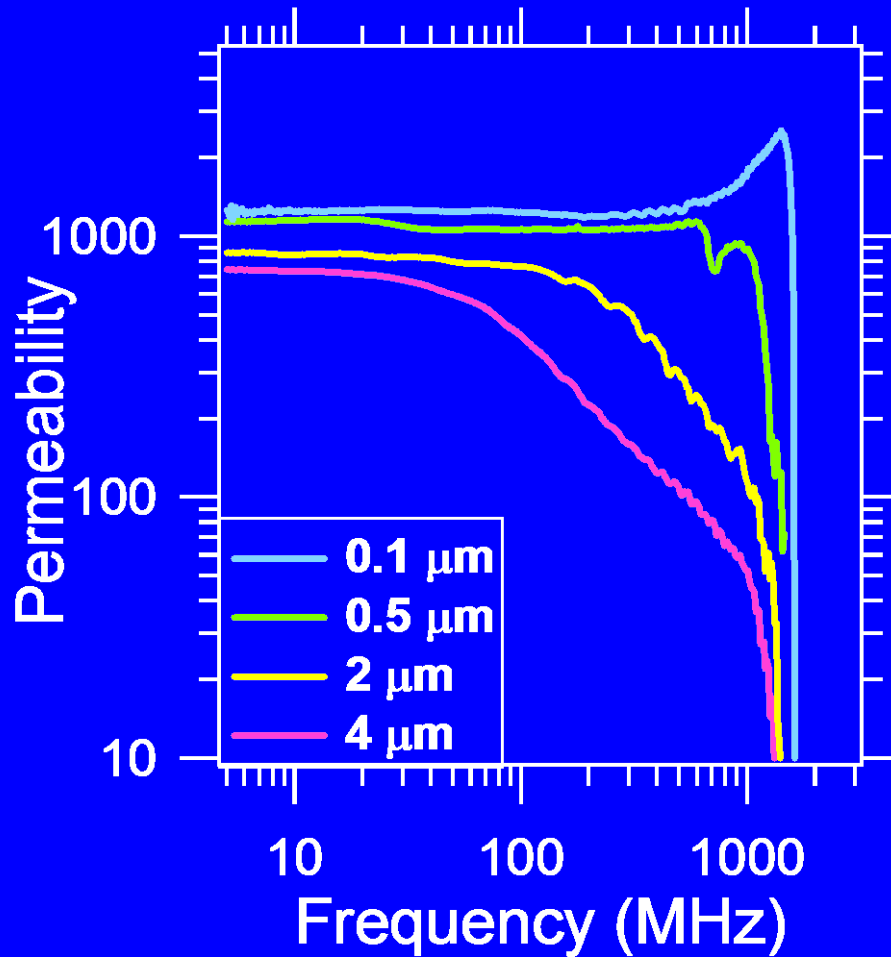

Imaginary Component

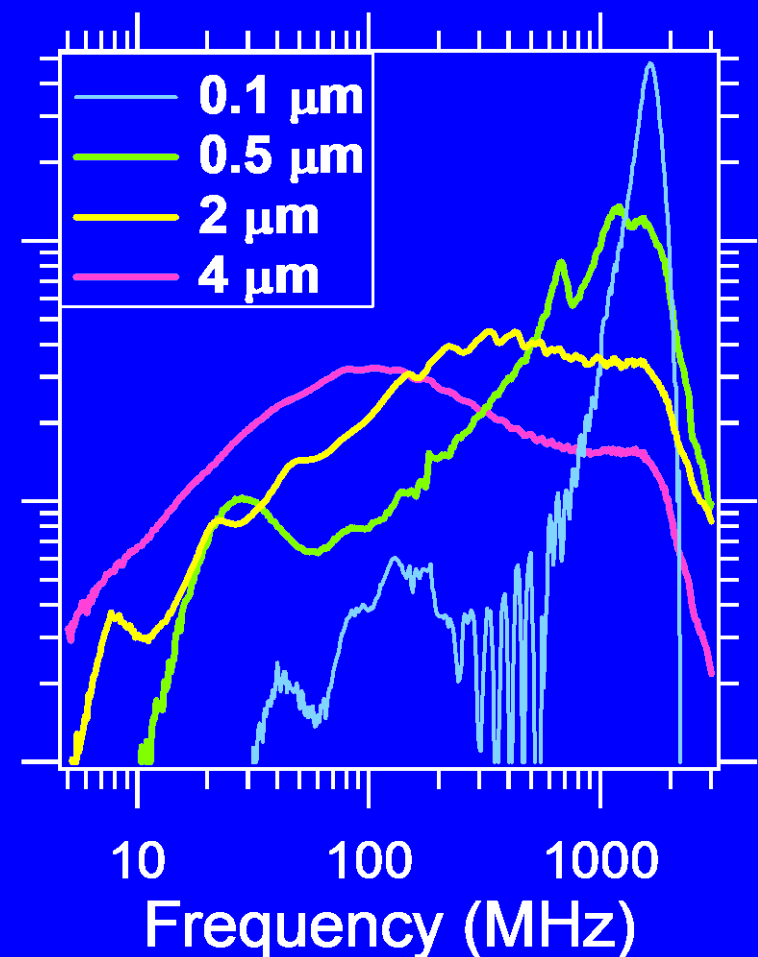

Permeability Spectra of CoZrTa

Real Component

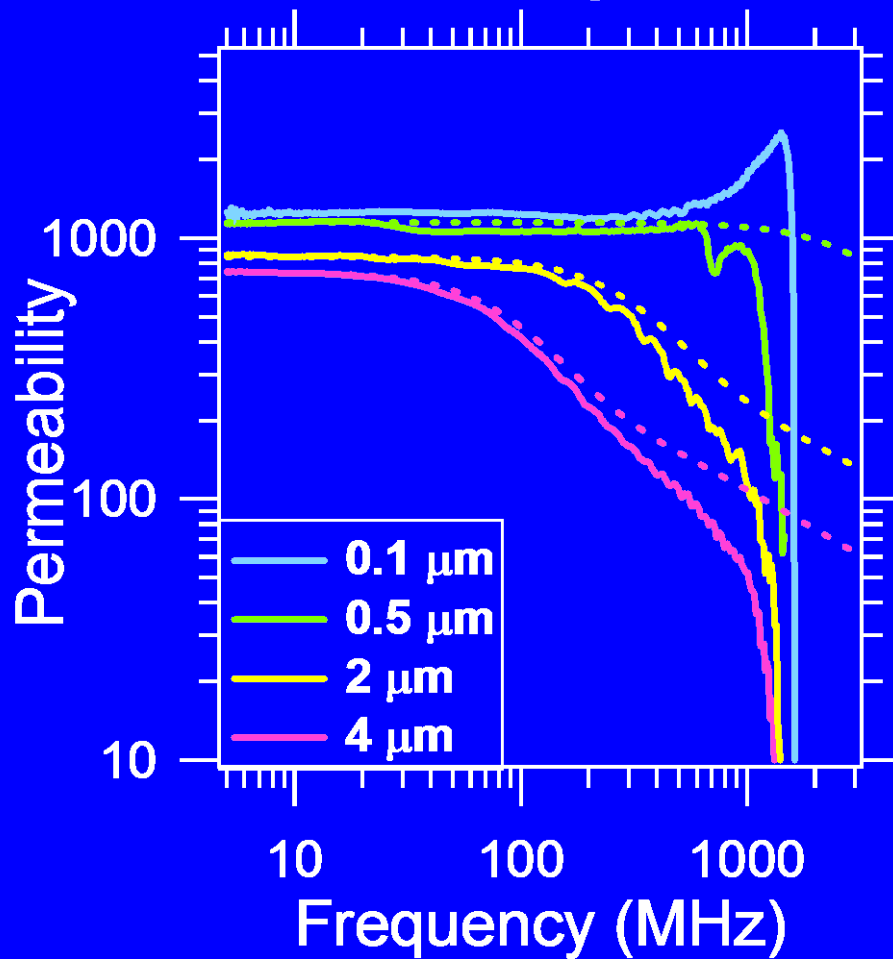

Imaginary Component

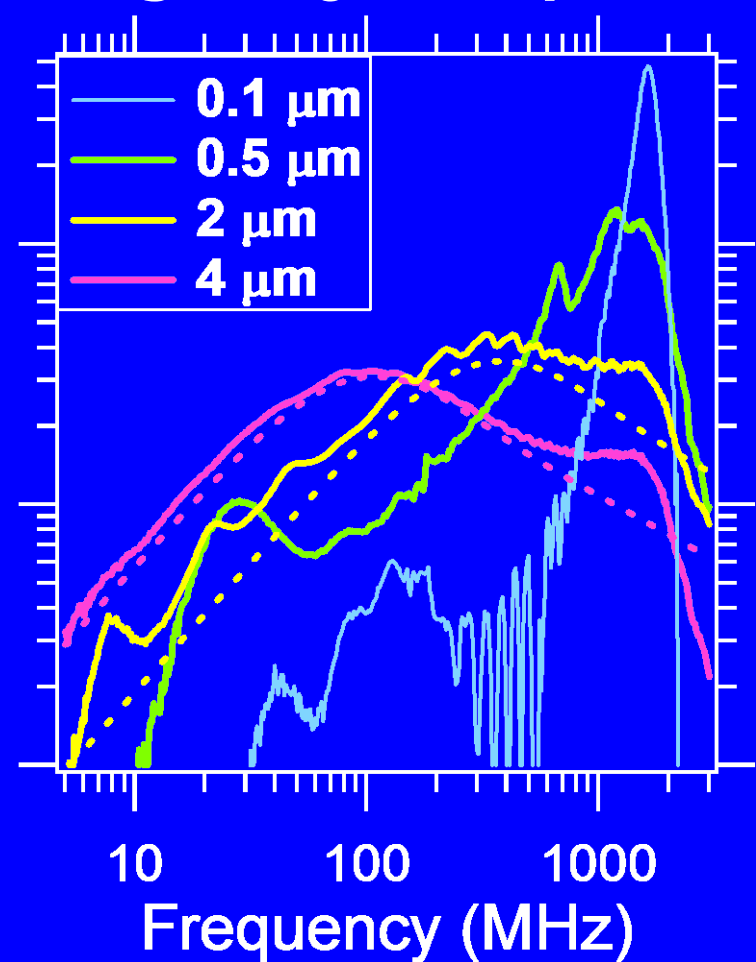

Inductance Modeling of Wire with Magnetic Material

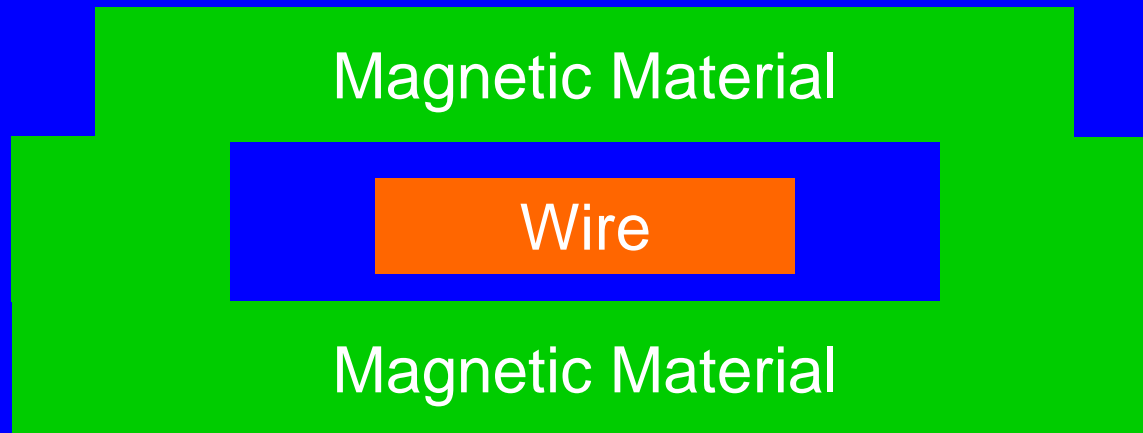

Maximum Increase in Inductance

1 layer magnetic film $\rightarrow \leq 2 \times$

2 layers magnetic film $\rightarrow \leq \mu_r \times$

Spiral and Transmission Line Inductors

Hard ↑
Easy →

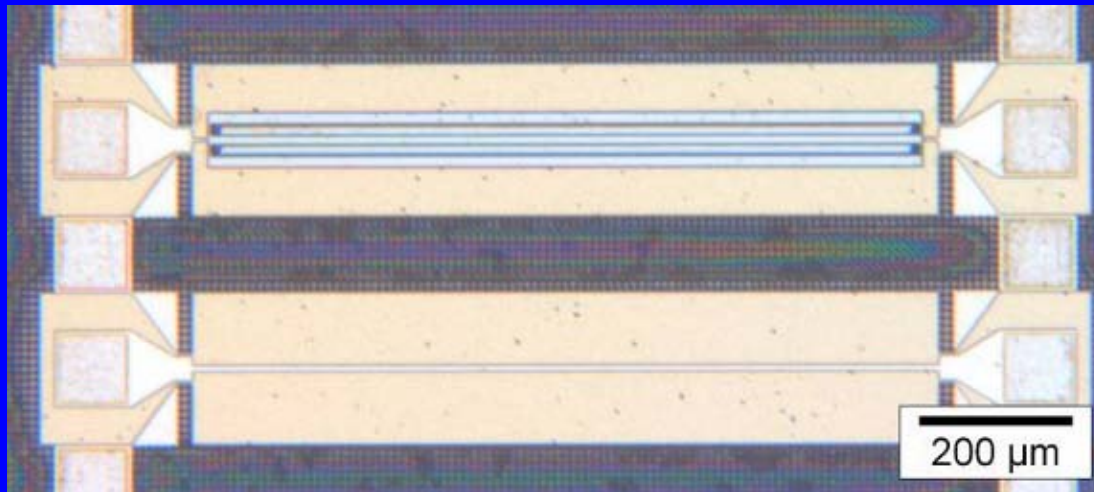
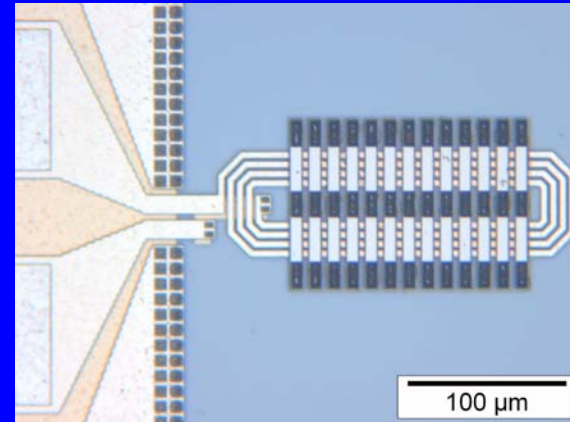
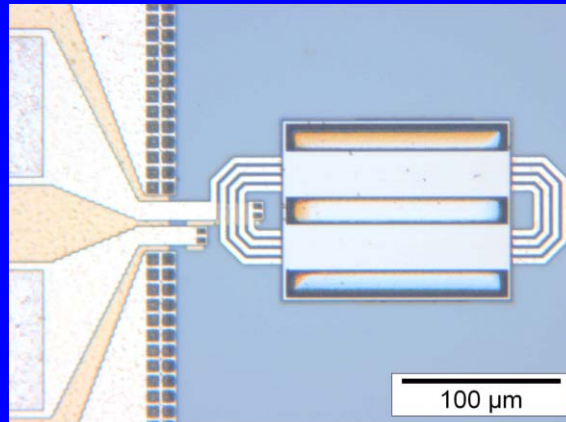

Structures take advantage of the uniaxial magnetic anisotropy.

Cross-Sectional Image of Inductor in 130 nm 6-level Metal CMOS Process

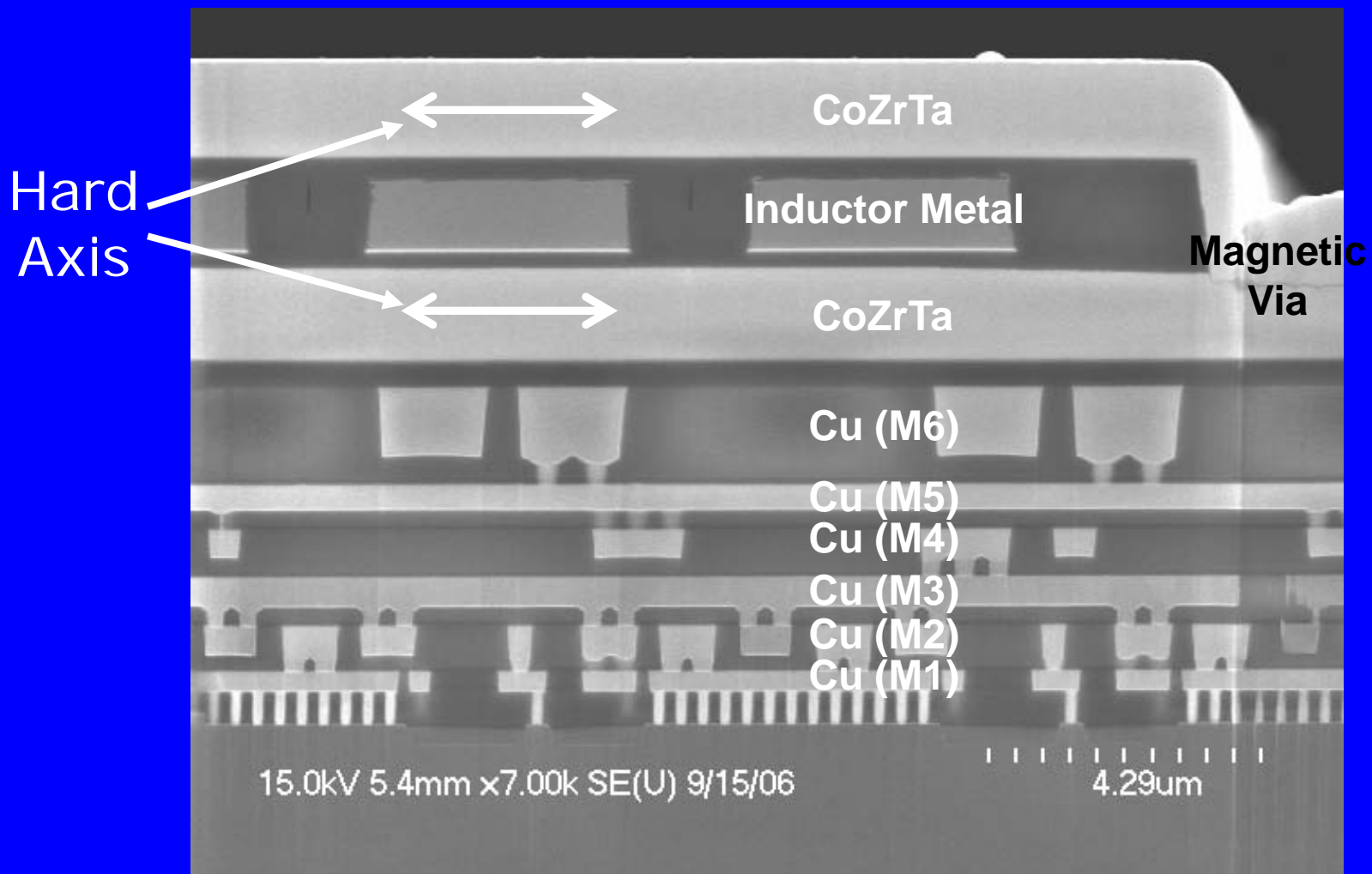

Spiral Inductors with Single Magnetic Layer

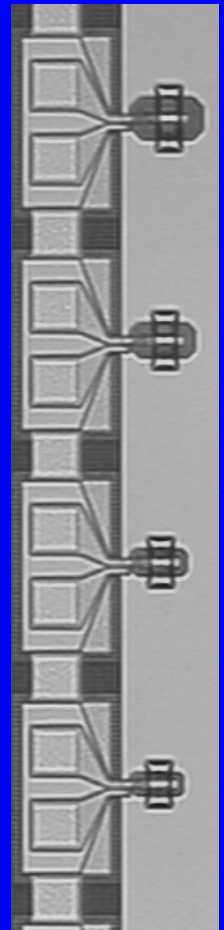
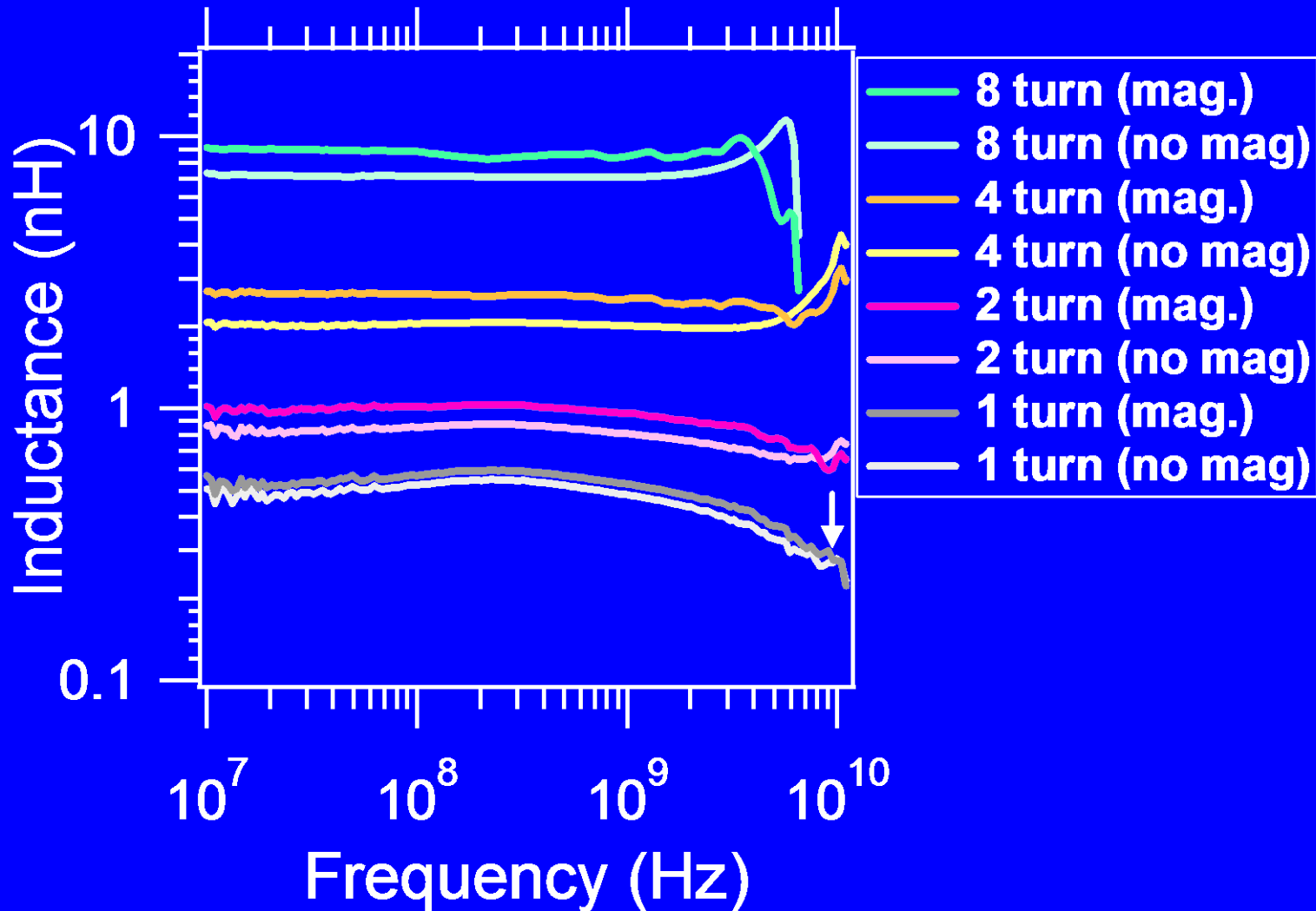

Increase in inductance is small (10~30% at up to 9.8 GHz)

Spiral Inductors with Two Magnetic Layers

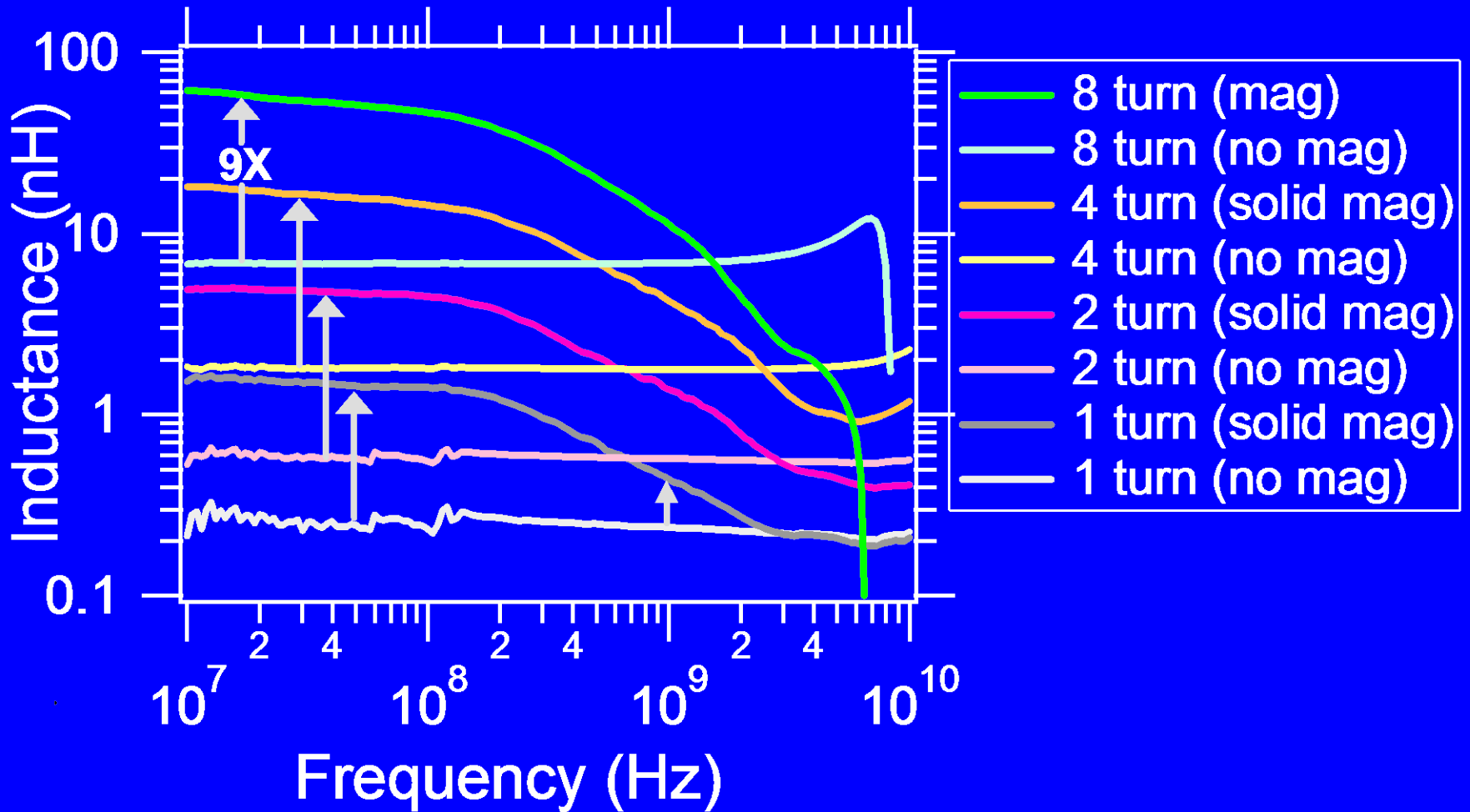

Inductance increases by 9 x

Magnetic Flux Density At 1GHz

Unlaminated
Cobalt alloy

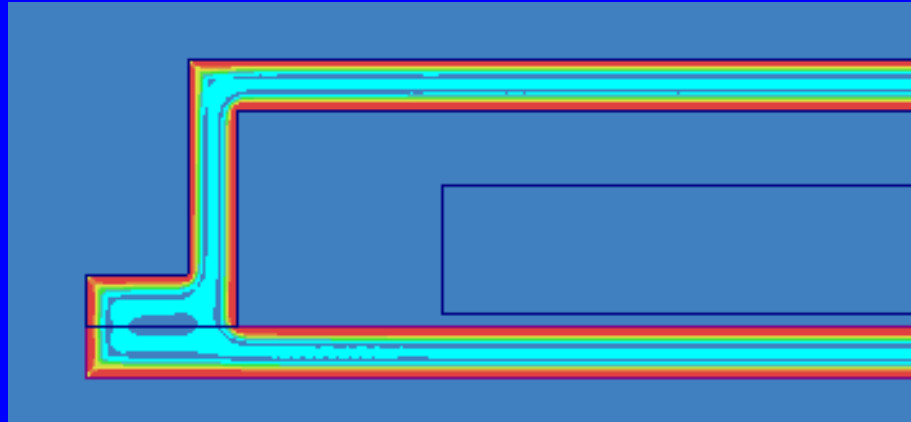

Laminated
Cobalt alloy

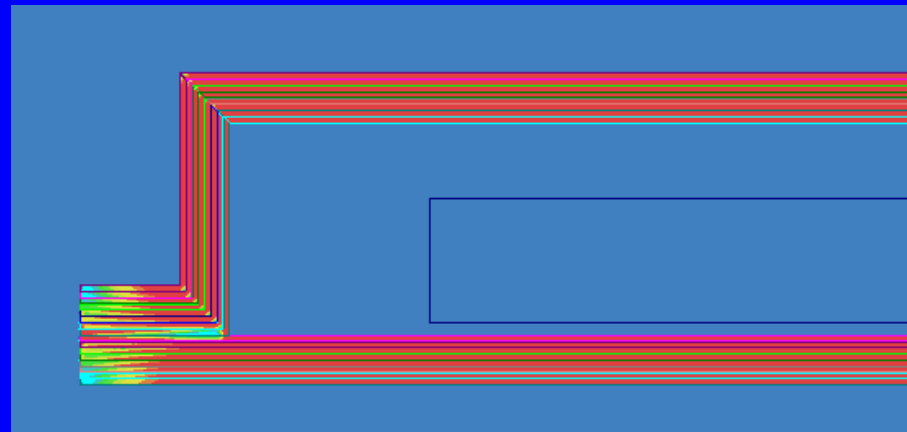

Skin-depth effect limits penetration of B-field.
Larger skin depth results in lower losses.

Inductance vs. Frequency of Spirals

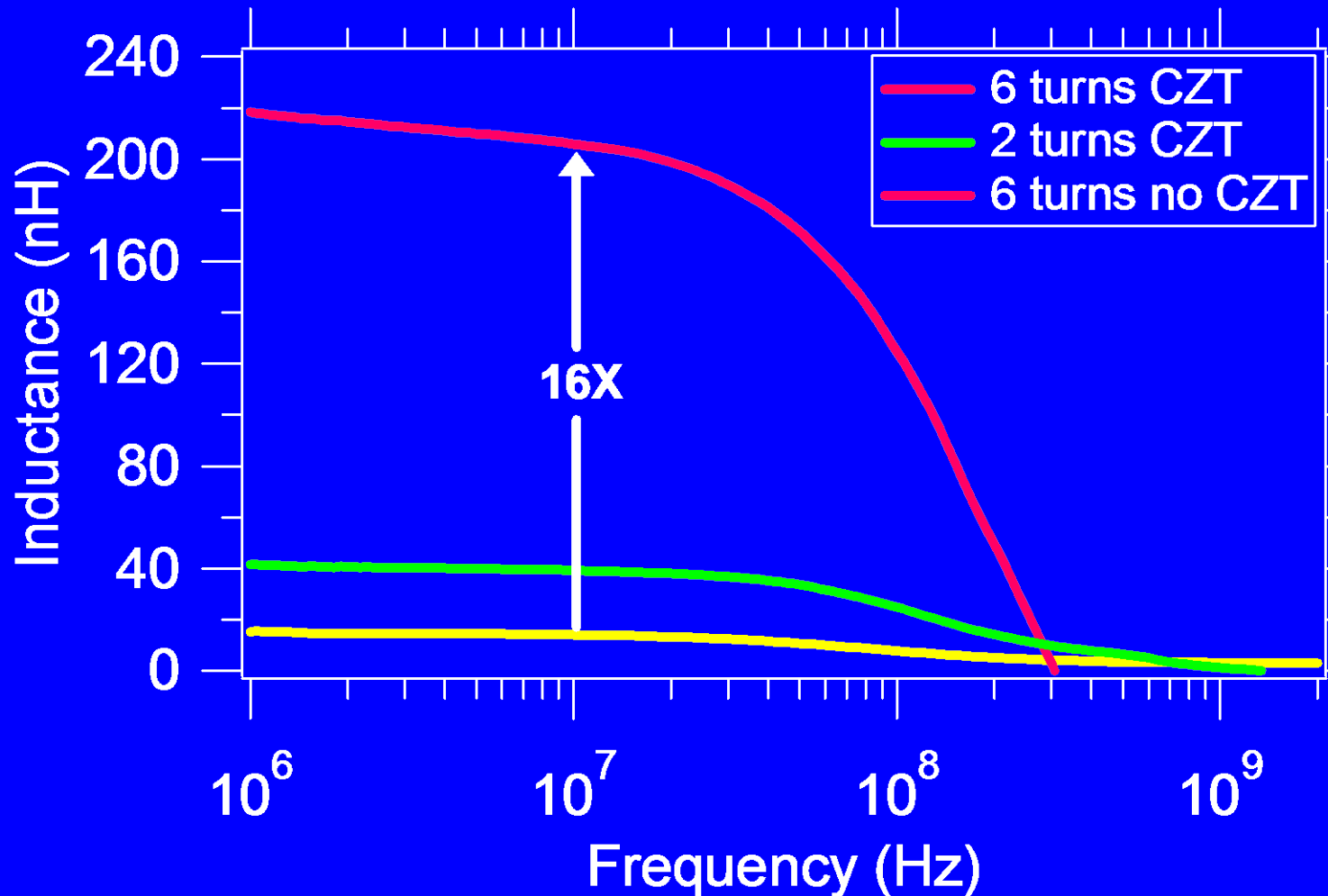

Inductance density is 1,700 nH/mm²

Roll off is from resonance ($1/\sqrt{LC}$) of inductor.

Spiral and Stripe Inductors Using 5 μ m thick Copper

Hard \uparrow
Easy \rightarrow

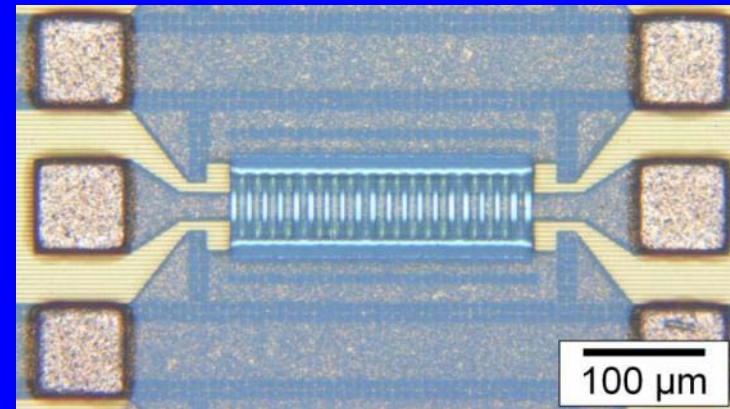
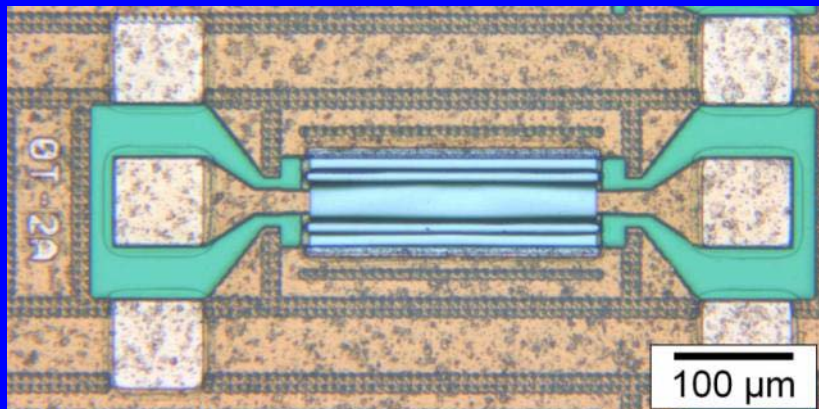
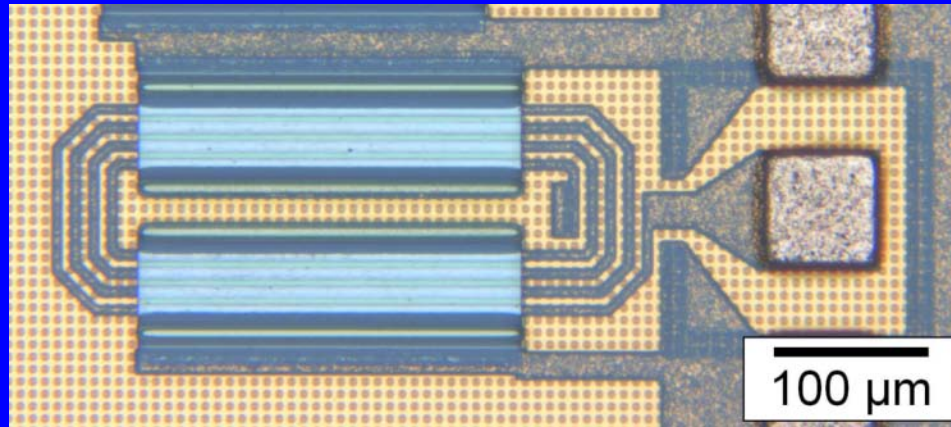

Structures take advantage of the uniaxial magnetic anisotropy.

Cross-Sectional Image of Inductor in 90 nm CMOS Process

Magnetic
Via

Magnetic
Via

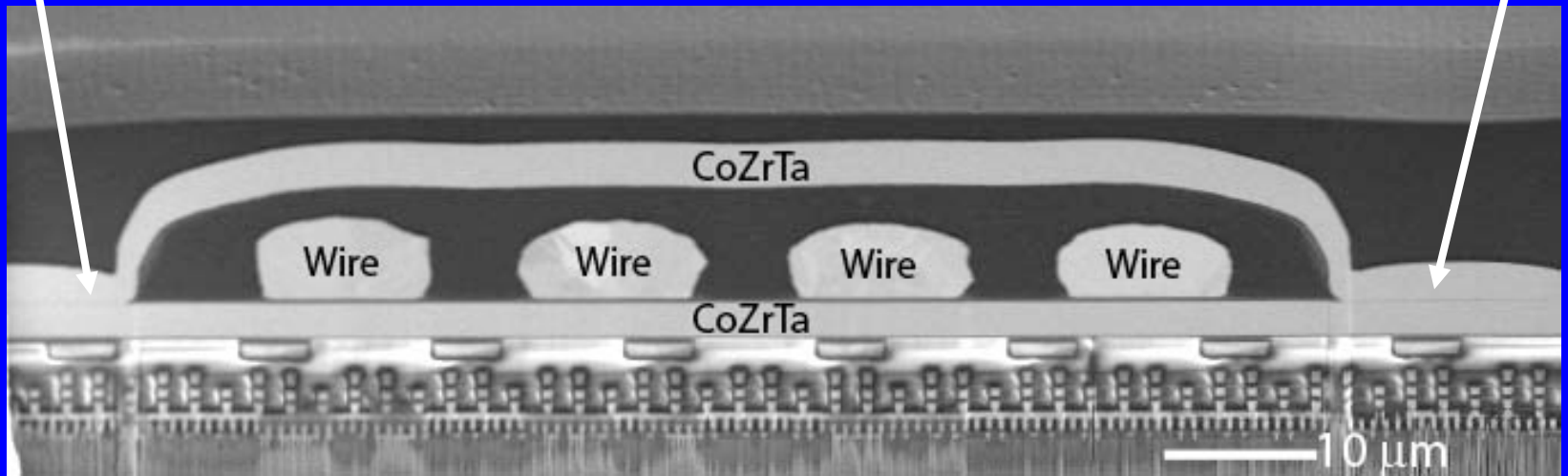

90 nm 7-level Metal CMOS Process

Cross-Sectional Image of Inductor

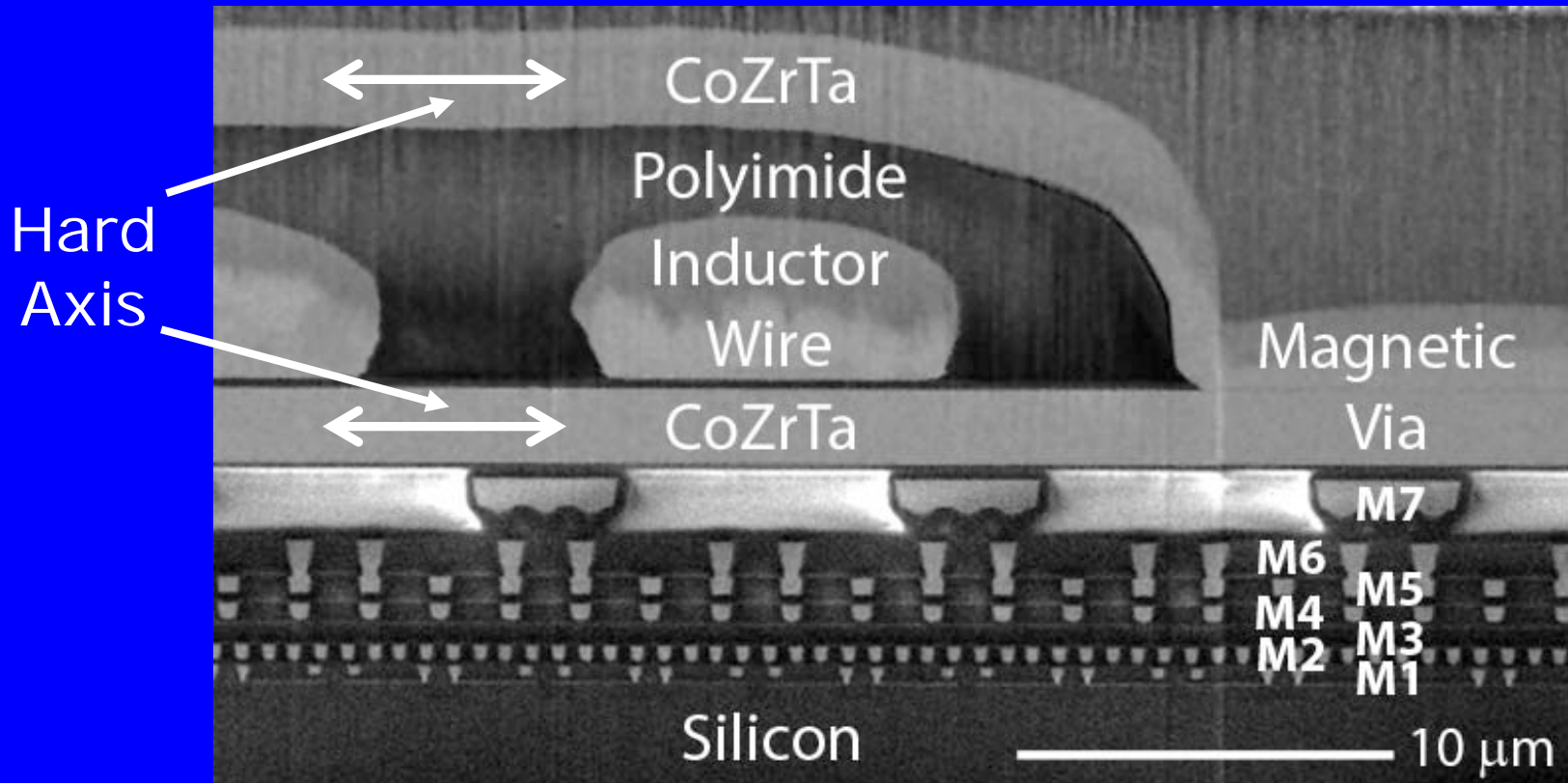

Stripe Inductors With Thick Copper

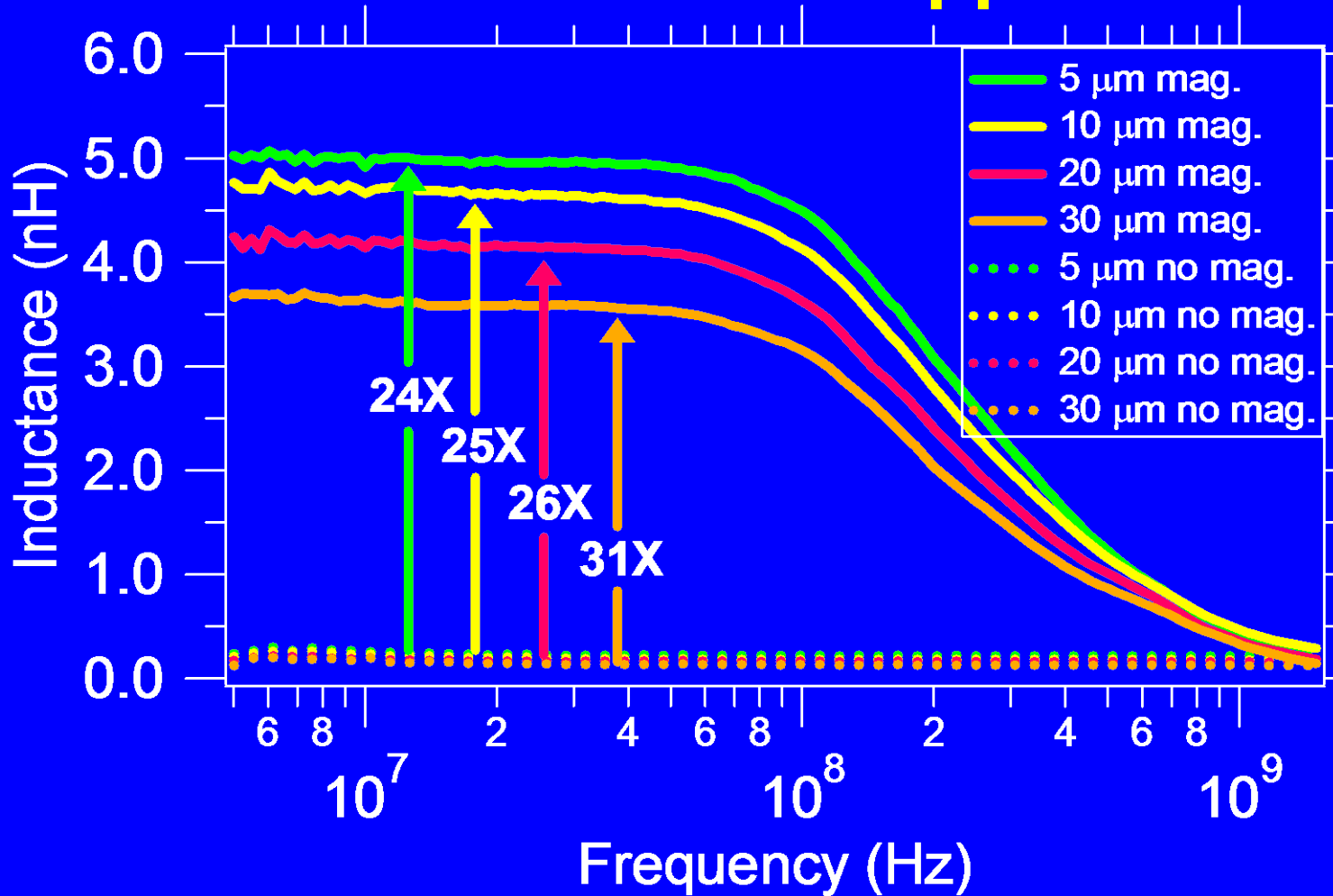

Inductance increases by up to over 30x

Inductance Modeling of Rectangular Line

$$L \approx \mu_0 \mu_r \frac{t_m}{2} \left(\frac{l}{w} \right)$$

l = line length

w = line width

t_m = magnetic film thickness

μ_r = relative dc permeability

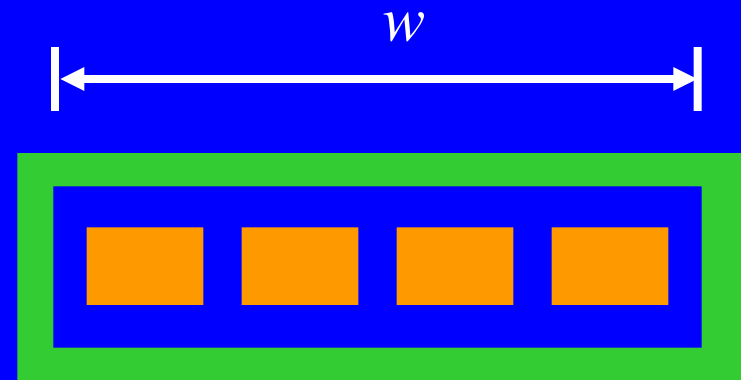
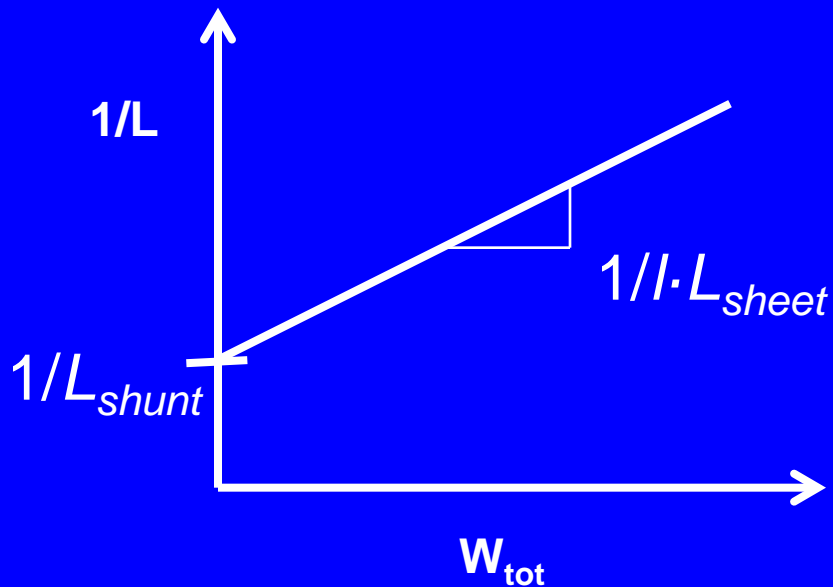

Magnetic Via Widths

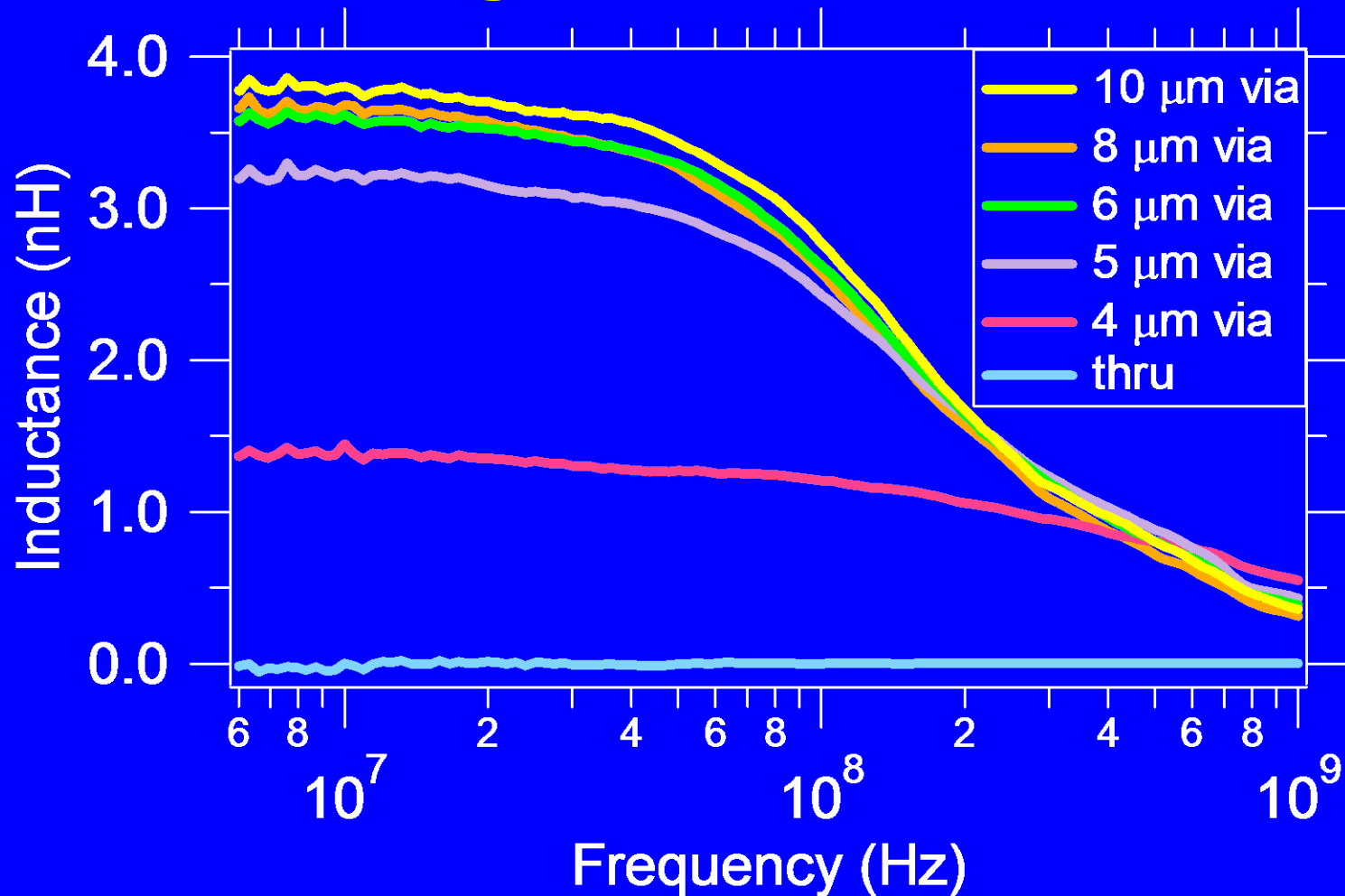

Inductance increases with via width, but the change becomes diminishingly small.

Sheet and Shunt Inductances

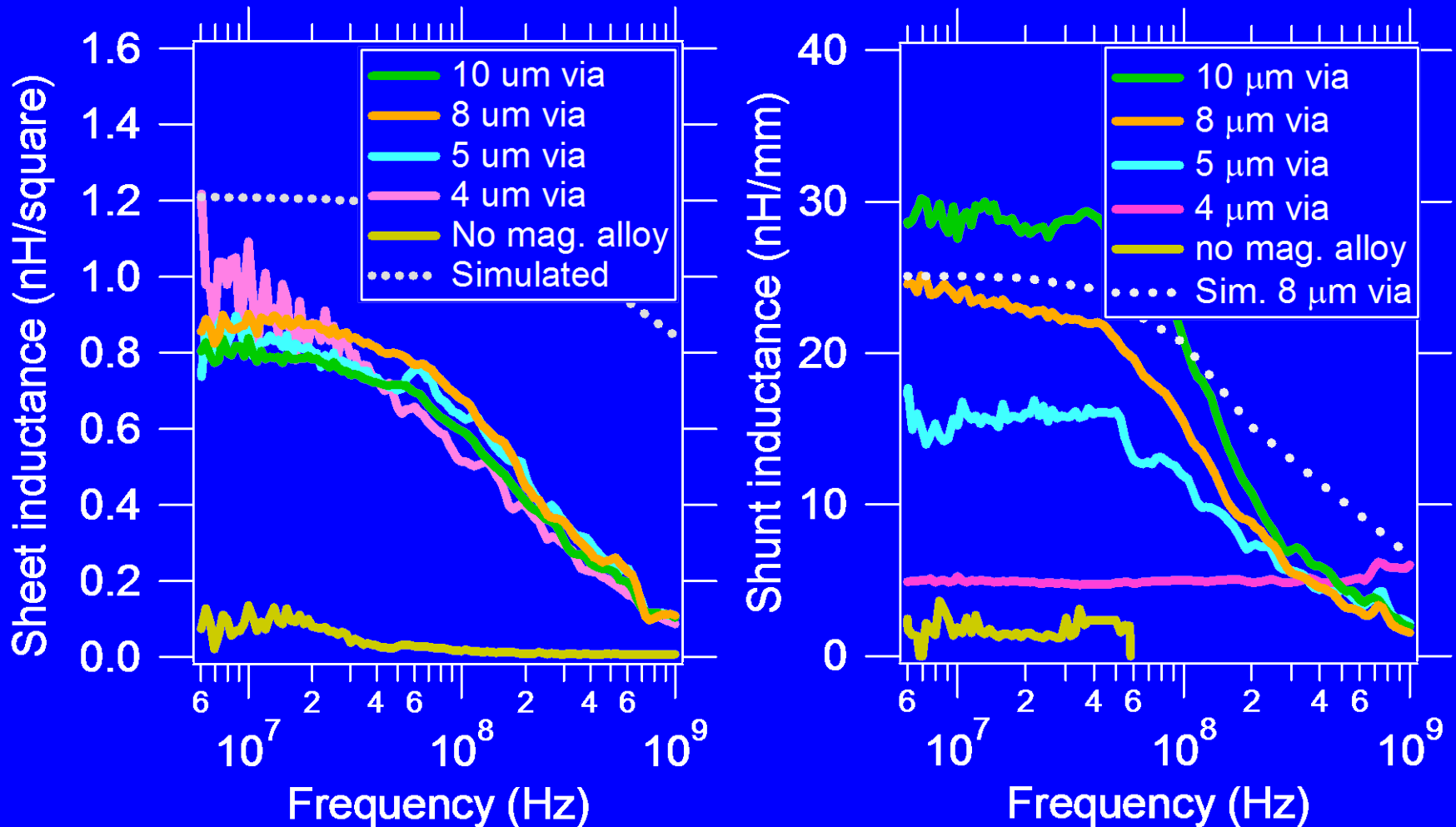

**Sheet inductance is independent of the magnetic via width.
Shunt inductance increases with increasing via width.**

Current Density At 100 MHz

Unlaminated
Cobalt alloy

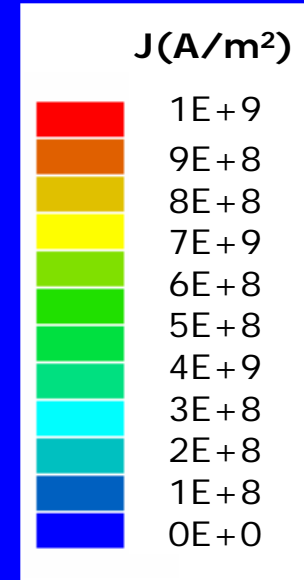
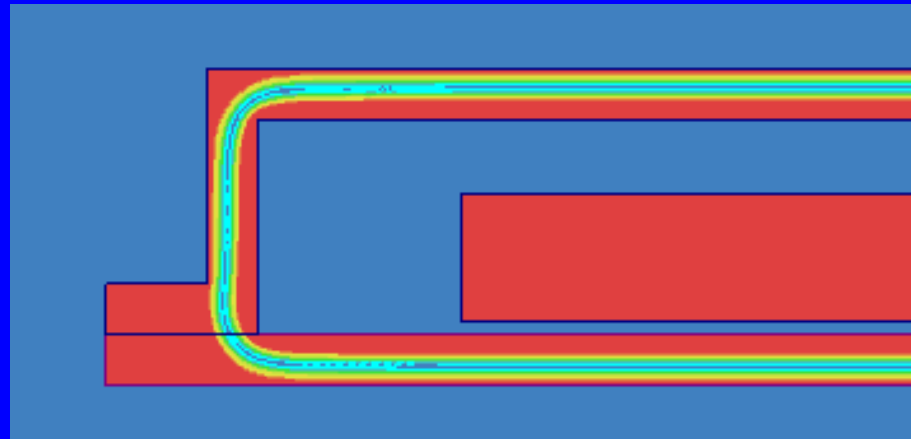

Laminated
Cobalt alloy

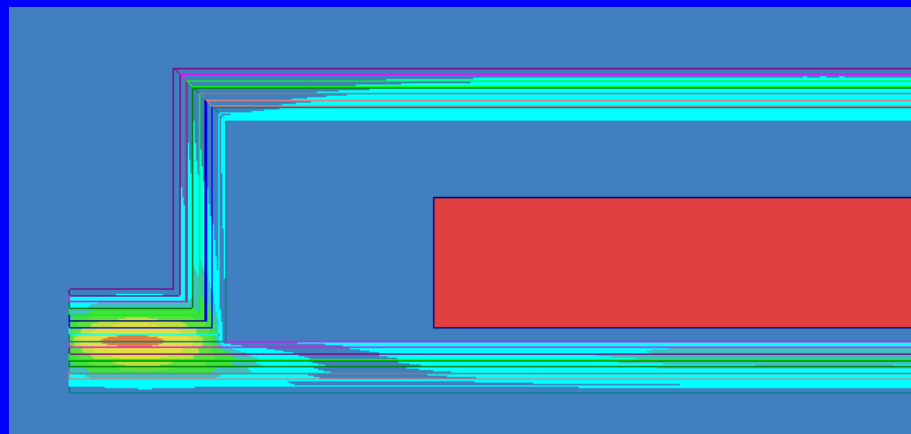

Eddy currents are reduced by laminations.

Analytical Modeling of Q-Factor

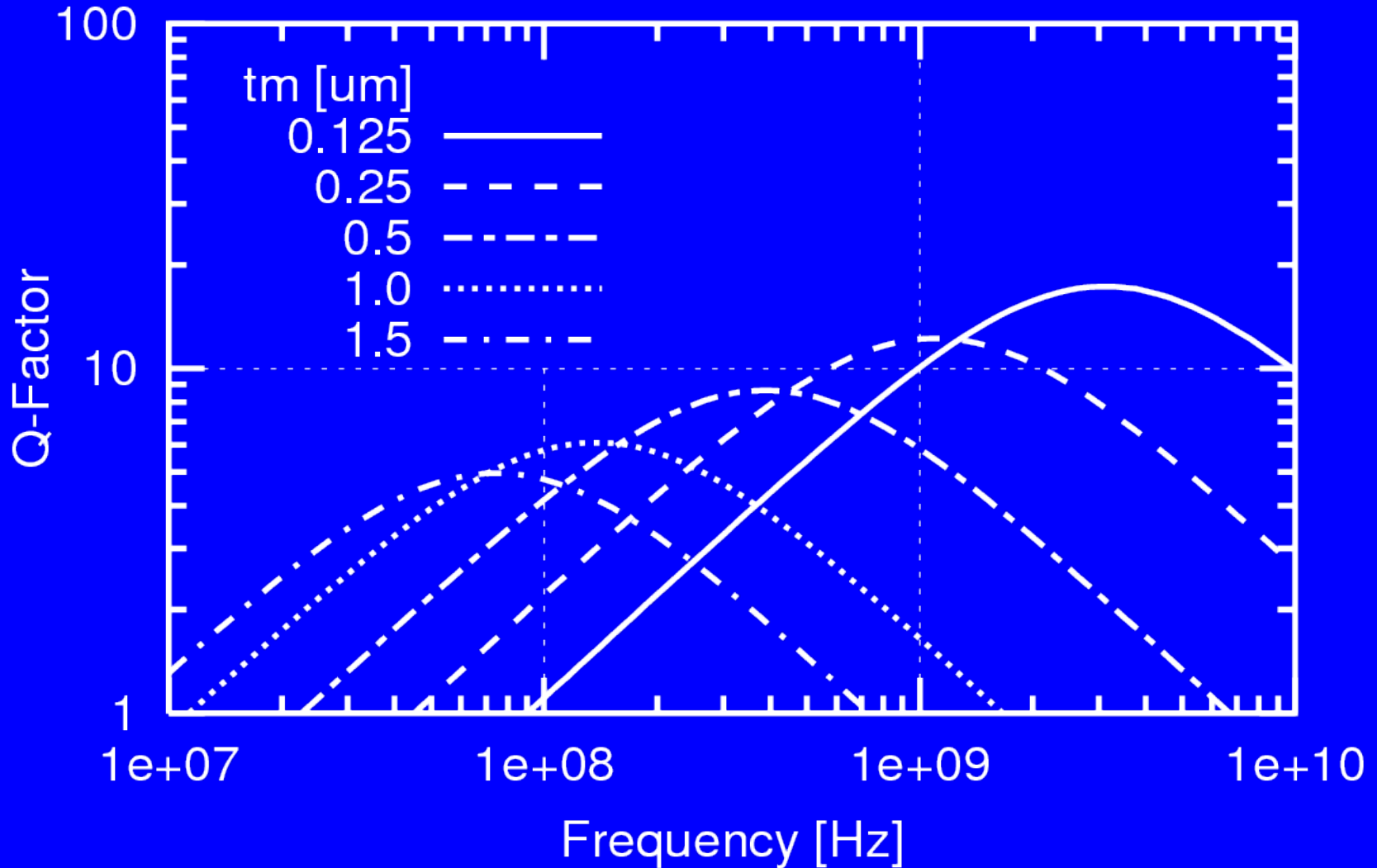

Thinner films give higher Q-factors, but lower inductance.

Analytical Modeling of Q-Factor

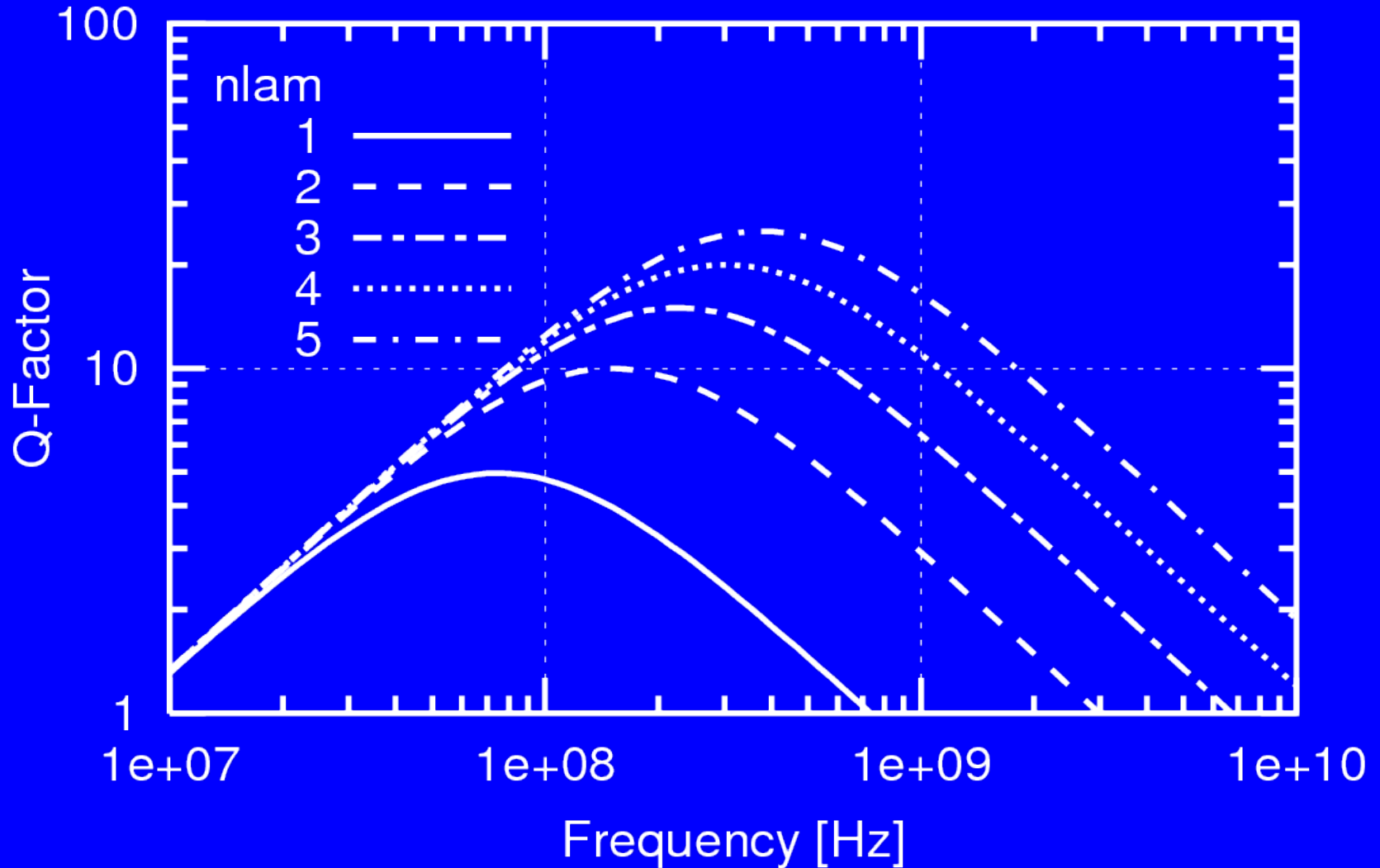

Laminations increase the Q-factor.

Quality Factor of Inductors With Laminated Magnetic Films

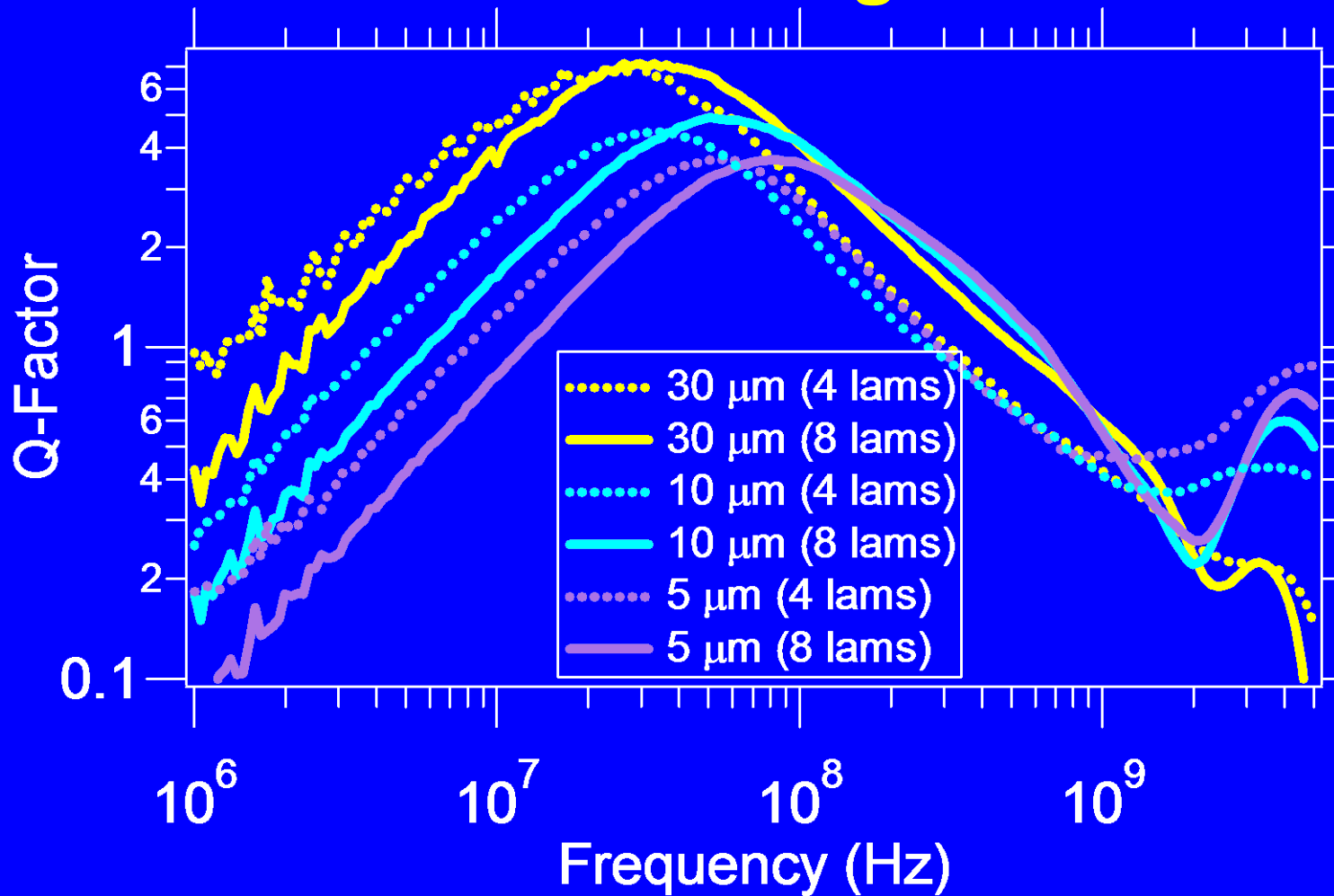

Peak quality factor is increased,
But quality factor at lower frequencies decreased.

Summary

- **DC Voltage Converters**
 - High-frequency buck converters
 - High inductance density needed
 - Low DC resistance important
- **Magnetic materials**
 - Complex permeability (real and imaginary)
 - Low hysteretic losses
 - CMOS compatibility (thermal, process compatibility)
- **Inductors with magnetic material**
 - Single films increase inductance by $\leq 30\%$ up to 9.8 GHz
 - Magnetic vias – Sheet inductance vs. shunt inductance
 - 2 magnetic films increase inductance
 - Over 30x compared to air-core
 - 200 nH inductors possible (1,700 nH/mm²)

For More Information

- IEEE Trans. Magnetics, **45**, pp. 4760, 2009.
- Journal of Applied Physics, **103**, pp. 07E927, Apr. 1, 2008.
- IEEE Trans. Magnetics, **43**, pp. 2615, 2007.
- IEEE PESC 2004 and IEEE VLSI Symp. 2004.
- APEC, Paper #SP1.4.2, p. 75, 2010.
- Intl. Electron Devices Meeting (IEDM), pp. 221-224, 2006.
- IEEE Intl. Interconnect Technology Conference, pp.101–103, 2001.

