

Electrons, Photons, Phonons, Wave, Bits, and Industrial Design: Microsoft Kinect Sensor

Hot Chips 23

Dawson Yee
Scott McEldowney

*Natural User Interface Hardware
Microsoft Corporation*

Topics

1. User Experience Goals
2. Design Considerations
3. Product Requirements
4. Design Tactics
5. System Overview
 - Major components & IC's
 - Depth
 - Audio
 - Thermal
 - Tilt
 - Mechanical structure
6. Other Considerations
 - Robustness
 - Test and Validation
 - Manufacturing and Supply chain

User Experience Goals

- Development of first large scale Natural User Interface System
 - Gesture, video and audio
 - State of the art
 - 3D Imaging
 - Array Microphone (Beam forming & Echo cancellation)
- New requirements
 - Play space range and field of view
 - Ambient light
 - Low lighting for video
 - High lighting for depth dynamic range
 - All room, clothing, etc.
 - Background noise
- Reliable and Affordable

Design Considerations

- Approachable (technology is hidden)
- Fits in with user environment
- Placement of device
- Ease of setup
- Discovery & ease of use
- Self recovery/diagnostics
- Graceful degradation
- Error notification
- Works with all Xbox 360 consoles
- Extensible for future applications and uses

Product Requirements

- Regulatory (EMC, RFI, RoHS,...)
- Reliability over time & cycles
- Operating temperature
- Hot spots
- Humidity
- Shipping stresses (vibration/shake/shock)
- User abuse
 - Drops
 - Dust

Design Tactics

- Don't know:
 - Future application requirements
 - User base (new segment)
 - User expectations (about performance)
- Do know:
 - Physics
 - Basic function
 - Schedule
 - Cost target
 - Manufacturing and supply chain constraints
- Approach:
 - Work by design (versus work by test)
 - Understand material limits
 - Understand technical limits
 - Control what you know
 - Design margin /conservative design

System Overview

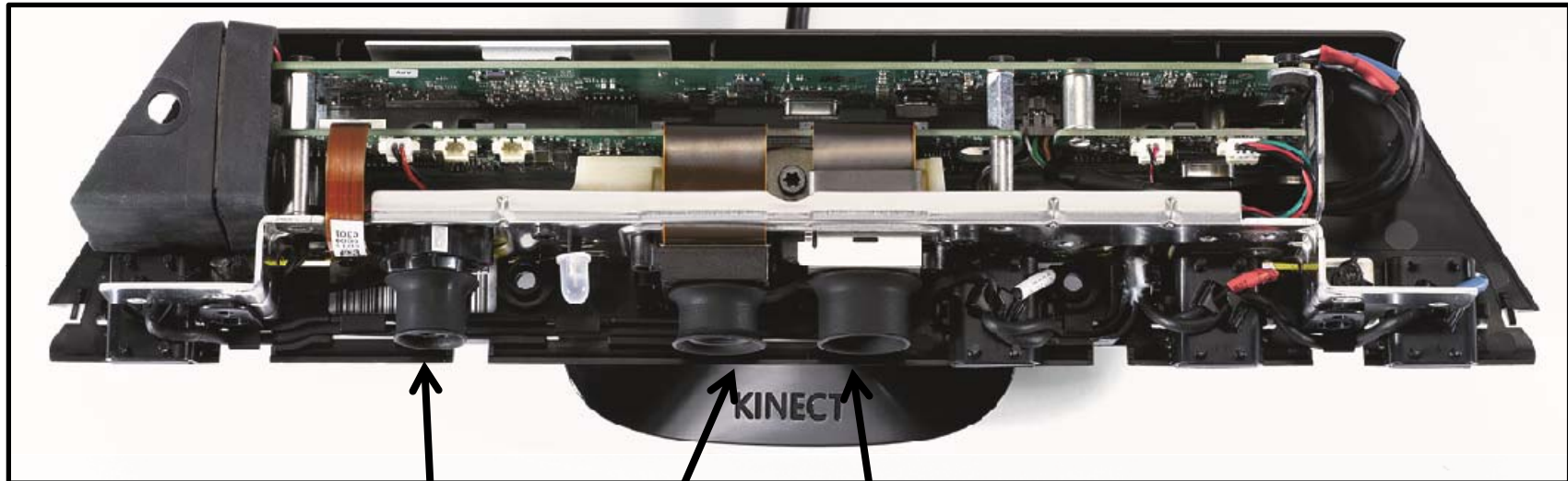

RGB Sensor

Near Infra-Red Illuminator (projector) and Depth Sensor

System Overview: Overall Assembly & Major Components

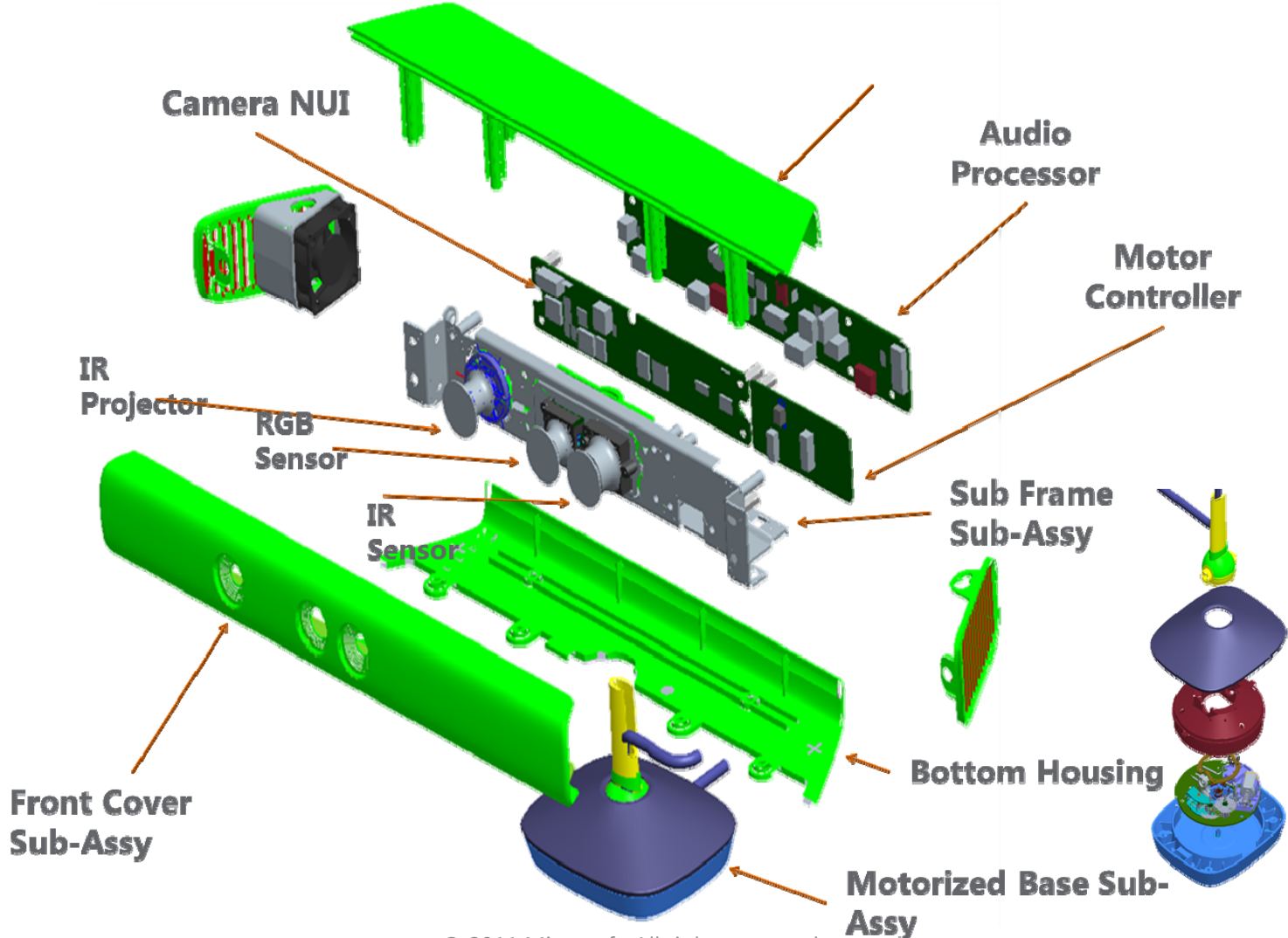

Major Components & IC's

- USB 2.0 interface (Hub)
- Data
 - Depth
 - RGB
 - Audio out
 - Audio in
 - Tilt

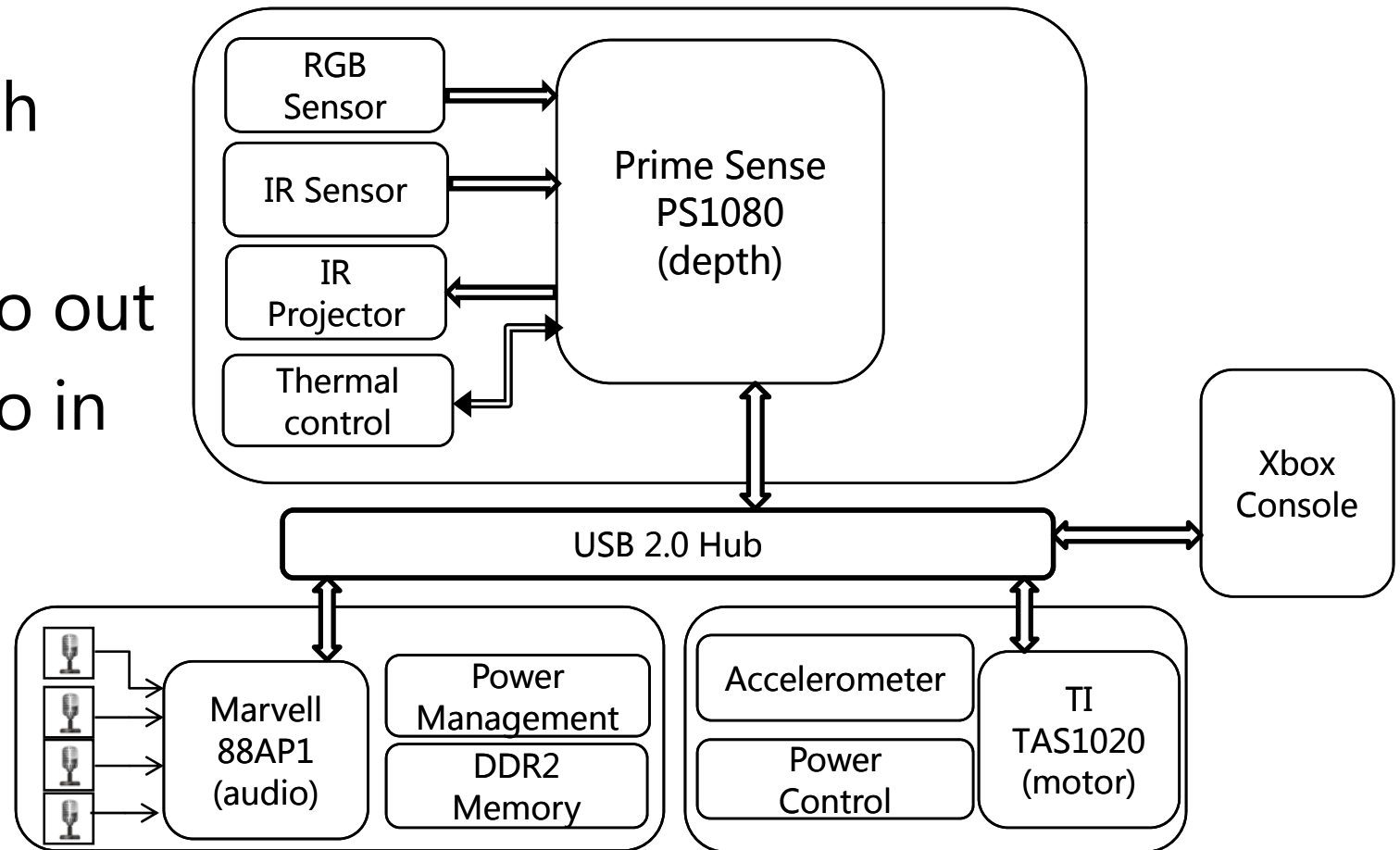

Depth: Overall Depth Sensor Design

- An infrared projector combined with a monochrome CMOS sensor allows Kinect to see the room in 3-D
- Structured Light
 - Illumination source
 - Pattern generation
 - Detector/sensor
- IR Sensor
 - High sensor responsivity reduces power consumption
 - Large FOV with low distortion and high MTF lens system
 - Narrow band pass filter reduces interference from ambient incandescent lighting
- Infrared Projector
 - Near IR Laser Diode
 - Laser diode Considerations
 - Temperature control (hold to fraction of degree C)
 - Over operating temp range within boot time
 - Mode Hopping
 - Feedback from other optics
 - Slow ramp
 - Immune to transients
 - Over power/current → catastrophic optical damage (COD)

Depth: Radiometric Design

- Sensor Power Budget
 - Ambient light (Incandescent & Halogen lights, Sun) - SNR
 - Quantum efficiency of sensor (responsiveness in amps generated /optical watt of power)
 - Near vs. Far (dynamic range of sensor) – $1/R^2$
 - Corner vs. Center (optics) – $\cos^4(q)$
 - Minimum object size (resolution, illumination) (FOV/pixels)
 - Reflectivity of objects
 - Contrast of Imaging System (MTF)
- Narrow band pass optical filter
 - Blocking undesired ambient light
 - Passing illumination source wavelength
 - Incident angles – wavelength/transmission shift with angle

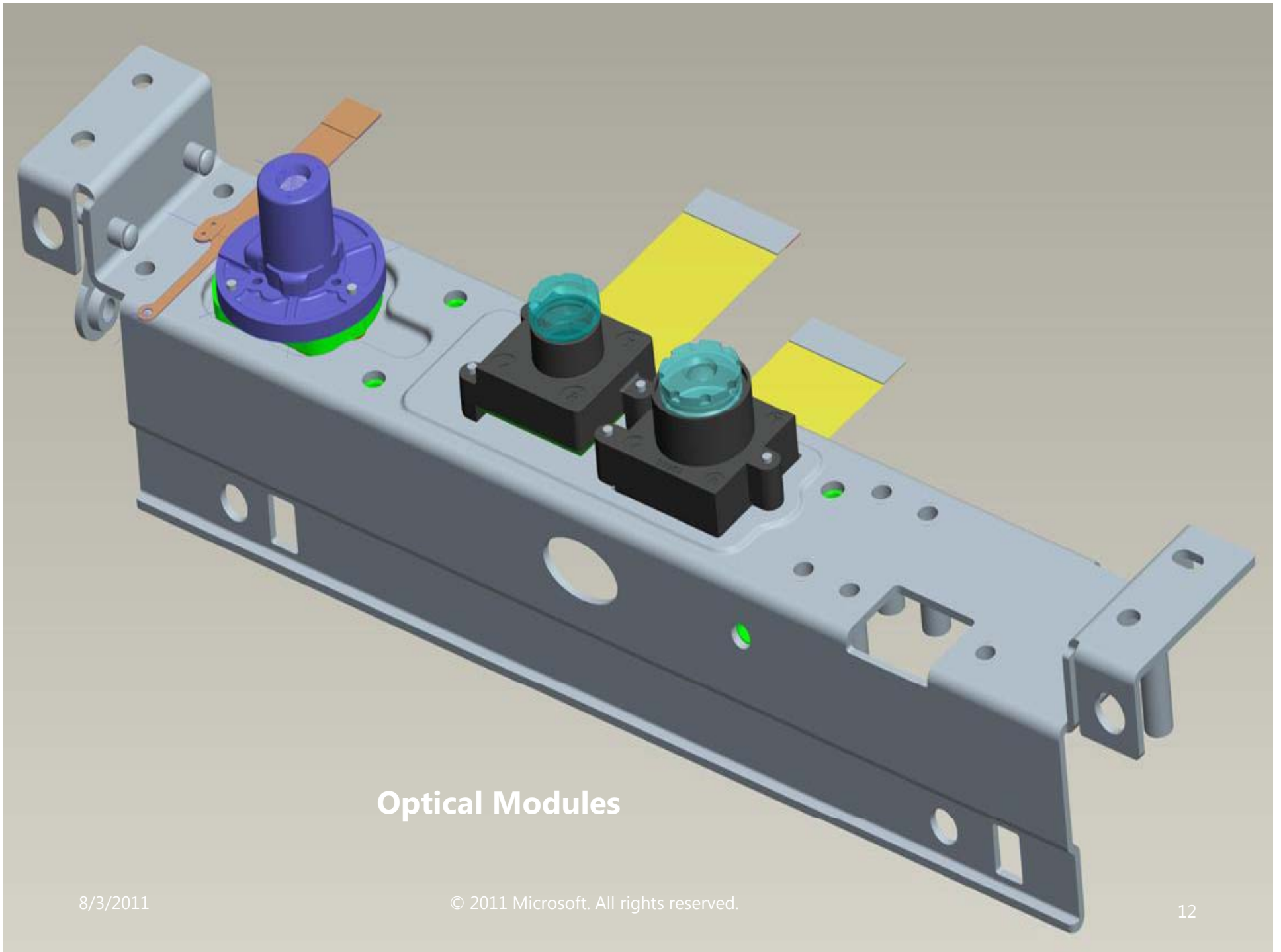

Optical Modules

Depth: Depth Error

- Calibration will ensure uniform accurate depth leaving the factory
- Must guarantee Uniform Across FOV, Temp, Time, Shake/Shock/Drop
- Mechanical alignment
 - Structured light principle is to measure illumination shift to sub-pixel levels so...
 - Sub-pixel shifts are important – tolerances measured in microns
 - Micron type deflections change depth
 - Drop
 - Temp cycles
 - Shipping
 - Metals and plastics
 - Change in lenses
 - Unintended stresses

Audio

- **Speech** commands (speech recognition)
- **Game chat** (directed full duplex with playback)
- **Video Conferencing** (further back, wider field, full duplex)
- Wideband audio 16kss @24bits
- 4 element beam forming input audio
 - Response matched to dB as built
 - Need to AEC each channel BEFORE beam forming
- Synchronization of Console 5.1 audio output with 4 microphone streams

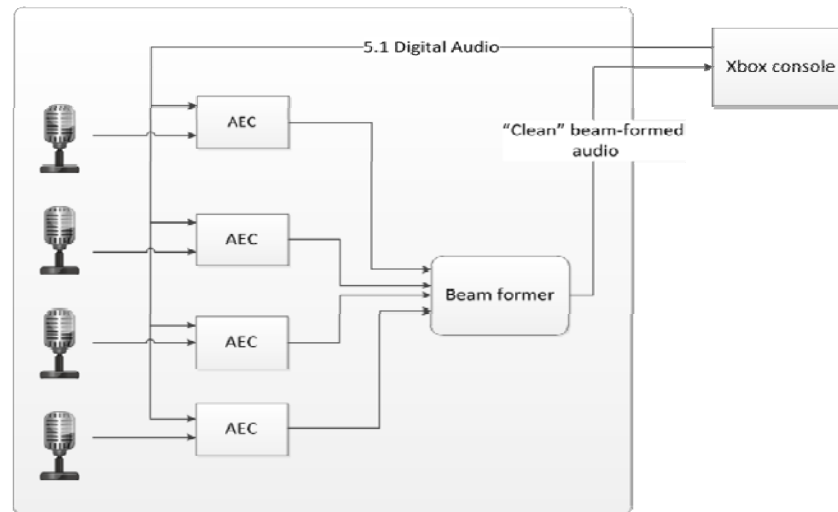

- Latency
- Received FAN noise
 - e.g. quiet talker @ 3m -> equivalent at sensor

Tilt

- Determine the play space (see the floor)
- Tall & shorter players
- Motor
- Accelerometer
- Speed tilt to target
- Accuracy
- Power draw (peak vs. RMS)
- Wear /thermal effects
- Reliability
- Acoustic noise

Mechanical Structure

- Industrial Design
- Surface fit and finish
- Manufacturing & Assembly (DfX)
- Physical acoustics (microphone, fan)
- Thermal
 - Component operation and reliability
 - Optical elements, Depth error, Case temperature
 - Fan acoustics, vibration & air turbulence (speech, chat, video conferencing)
- Optical alignment
- Shake/shock/shipping/storage
- Impact
- Weight

Other Considerations: Robustness

- Watchdog timers
- Shutdown events
- Recovery from (unintentional) thermal overload
- Error event logging
- Power delivery
 - 12v and 5v for Xbox 360s
 - 5v from Xbox 360 + auxiliary 12v supply
 - 3m extender cable (voltage & power budget)
 - Peak loading (i.e. motor moves)
 - Transient immunity
- Firmware updates
- Ongoing reliability testing

Other Considerations: Test and Validation

- New category, new technology, new methods
- Stress validation (electrical/mechanical/optical/acoustic)
- USB stress (throughput/lost packets)
- Mechanical changes over temperature (optical, acoustic, cooling, tilt)
- Thermal stress & thermal capacity
- Stable operation time from cold or hot start

Other Considerations:

Manufacturing and Supply chain

- Unknown new market - skepticism
- “Telecom quality and reliability at consumer price points”
- New suppliers – different industries
- Stretched supply chains (cross-applications)
- Blind & Buried VIA's
- New assembly processes (molding, stamping, casting, coatings, glues (Tg & modulus, UV, outgassing))

Acknowledgement