



# Poulson: An 8 Core 32 nm Next Generation Intel® Itanium® Processor

Steve Undy  
Intel®

# Legal Disclaimer

- INFORMATION IN THIS DOCUMENT IS PROVIDED IN CONNECTION WITH INTEL® PRODUCTS. NO LICENSE, EXPRESS OR IMPLIED, BY ESTOPPEL OR OTHERWISE, TO ANY INTELLECTUAL PROPERTY RIGHTS IS GRANTED BY THIS DOCUMENT. EXCEPT AS PROVIDED IN INTEL'S TERMS AND CONDITIONS OF SALE FOR SUCH PRODUCTS, INTEL ASSUMES NO LIABILITY WHATSOEVER, AND INTEL DISCLAIMS ANY EXPRESS OR IMPLIED WARRANTY, RELATING TO SALE AND/OR USE OF INTEL® PRODUCTS INCLUDING LIABILITY OR WARRANTIES RELATING TO FITNESS FOR A PARTICULAR PURPOSE, MERCHANTABILITY, OR INFRINGEMENT OF ANY PATENT, COPYRIGHT OR OTHER INTELLECTUAL PROPERTY RIGHT. INTEL PRODUCTS ARE NOT INTENDED FOR USE IN MEDICAL, LIFE SAVING, OR LIFE SUSTAINING APPLICATIONS.
  - Intel may make changes to specifications and product descriptions at any time, without notice.
    - Software and workloads used in performance tests may have been optimized for performance only on Intel microprocessors. Performance tests, such as SYSmark and MobileMark, are measured using specific computer systems, components, software, operations and functions. Any change to any of those factors may cause the results to vary. You should consult other information and performance tests to assist you in fully evaluating your contemplated purchases, including the performance of that product when combined with other products.
    - Configurations: [describe config + what test used + who did testing]. For more information go to <http://www.intel.com/performance>
  - Intel does not control or audit the design or implementation of third party benchmarks or Web sites referenced in this document. Intel encourages all of its customers to visit the referenced Web sites or others where similar performance benchmarks are reported and confirm whether the referenced benchmarks are accurate and reflect performance of systems available for purchase.
  - Intel processor numbers are not a measure of performance. Processor numbers differentiate features within each processor family, not across different processor families. See [www.intel.com/products/processor\\_number](http://www.intel.com/products/processor_number) for details.
  - Intel, processors, chipsets, and desktop boards may contain design defects or errors known as errata, which may cause the product to deviate from published specifications. Current characterized errata are available on request.
    - The code names "Poulson" and "Tukwila" presented in this document are only for use by Intel to identify products, technologies, or services in development, that have not been made commercially available to the public, i.e., announced, launched or shipped. They are not "commercial" names for products or services and are not intended to function as trademarks.
  - Intel, Intel Itanium, Itanium, Intel Xeon, Intel Core microarchitecture, and the Intel logo are trademarks or registered trademarks of Intel Corporation or its subsidiaries in the United States and other countries.

Copyright © 2011 Intel Corporation. All rights reserved.

# Agenda

Design Space

Overview

Parallelism

Data Integrity

Power

Conclusion

# Design Space: Mission Critical

## Performance

- Both single-thread speed and total throughput are important
- Goal: > 2x generational performance improvement

## Scalability

- Glueless up to 8 sockets
- Support larger topologies via node controllers from system vendors

## Reliability

- Redundancy and self-correction
- Error detection and recovery via hardware and firmware

## Compatibility

- Socket compatible with Itanium® 9300 Processor Series (Tukwila)
- Common platform ingredients with Xeon® E7 Processor Series

# Poulson Overview

	Tukwila	Poulson
Process	65nm	32nm
Devices	2.05 Billion	3.1 Billion
Area	700 mm <sup>2</sup>	544 mm <sup>2</sup>
Power (max TDP)	185W	170W
Itanium <sup>®</sup> Cores	4	8
Last Level Cache Size	24MB	32MB
Intel <sup>®</sup> QuickPath Interconnect Links	4 full + 2 half	4 full + 2 half
Intel <sup>®</sup> QPI Link Speed	4.8GT/s	6.4GT/s
Intel <sup>®</sup> Scalable Memory Interface Links	4	4
Intel <sup>®</sup> SMI Link Speed	4.8GT/s	6.4GT/s

# Poulson Overview

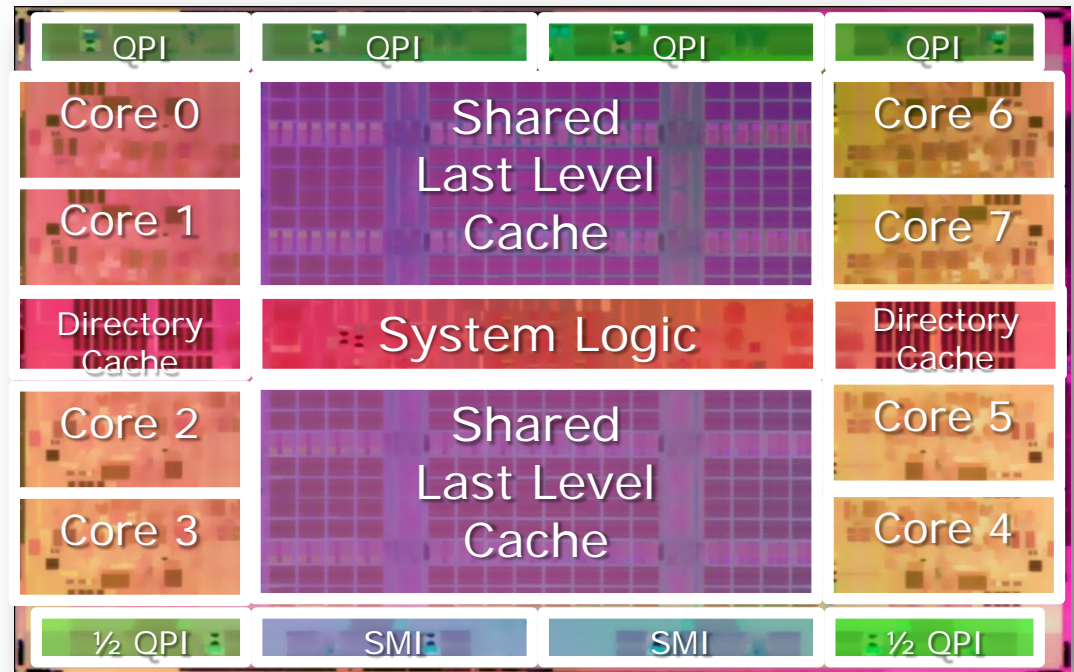

8 Itanium® Cores

32MB Last Level Cache

4 full-width and 2 half-width Intel® QPI links

2 Directory caches

2 Integrated memory controllers with 2 Intel® SMI links each

# Example 8-Socket Topology

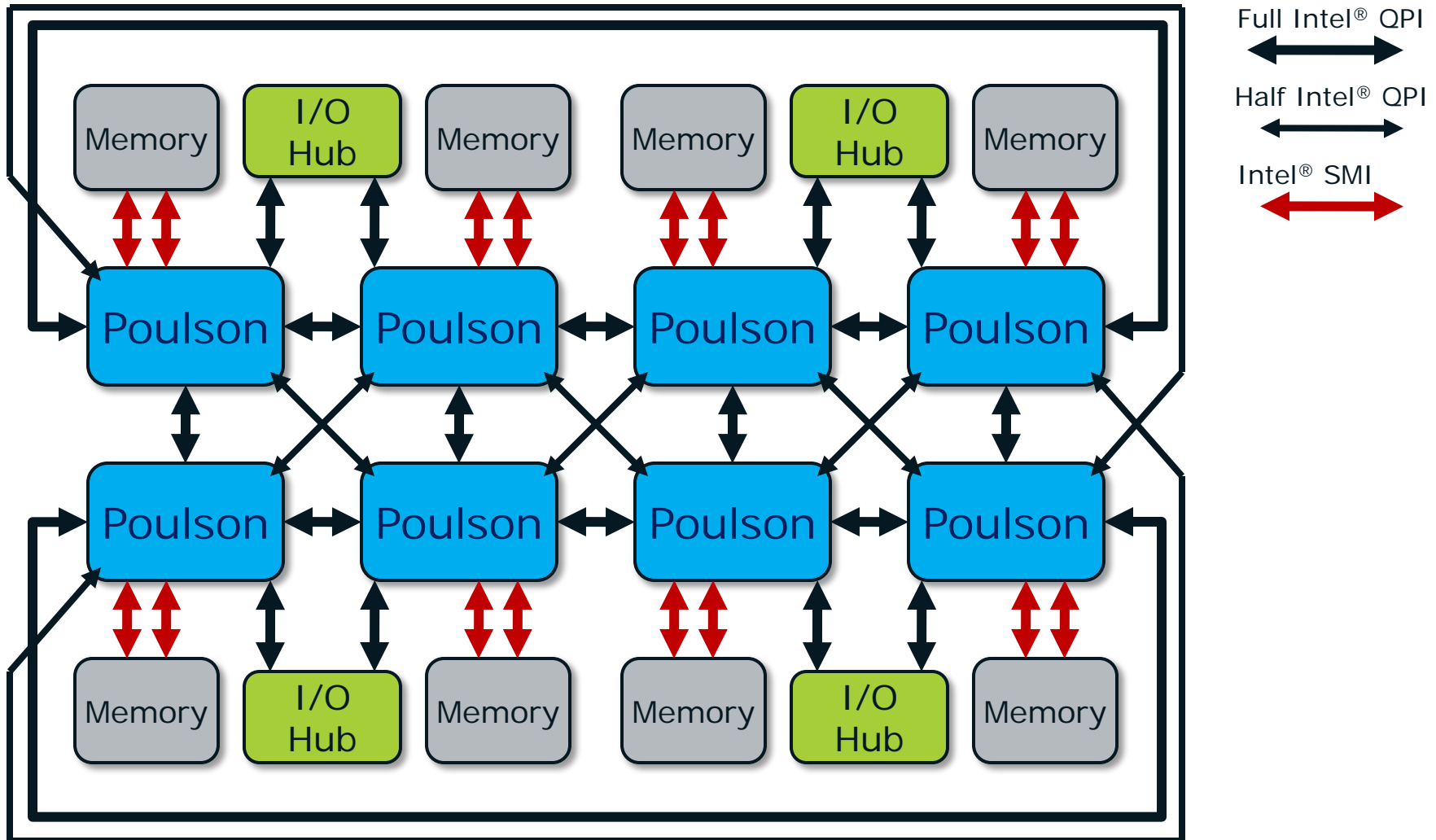

# Poulson Core

	Tukwila	Poulson
Devices	108 million	89 million
Area	69 mm <sup>2</sup>	20 mm <sup>2</sup>
Process scaled power @ TDP	1.0	0.4
Process scaled frequency	1.0	>1.2
Threads	2	2+2
Instruction Q size	48	96x2
Max instruction issue/cycle	6	12
Pipeline stages	2 + 6	4 + 7
Pipeline hazard resolution	Interlock+Stall	Replay
Integer RF size	144	185
Integer RF ports	12R 8W	12R 12W
RF protection	Parity	SECDED

**All-new Itanium® core**

Intel and the Intel logo are trademarks or registered trademarks of Intel Corporation the U. S. and other countries. Other names and brands may be claimed as the property of others. All products, dates, and figures are preliminary and are subject to change without any notice. Copyright © 2011, Intel Corporation.

Intel Confidential



# Itanium® New Instructions

## Integer operations

- mpy4
- mpyshl4
- clz

## Thread Control

- hint@priority

## Expanded Data Access Hints

- mov dahr

## Expanded Software Prefetch

- lfetch.count

# Exploiting Parallelism on All Levels

Instruction Level Parallelism

Memory Parallelism

Thread Parallelism

Multi-core Parallelism

**Multi-level parallelism exposed to software control**

# Instruction Parallelism

## Front-end Pipeline

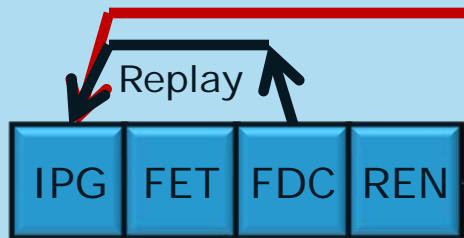

IPG: Address Gen  
 FET: Array Access  
 FDC: Early Decode  
 REN: Register Rename

Fetch width: 32B/cycle  
 Multi-level branch Prediction  
 Renaming: 128 logical to  
 185 physical registers

Independent thread domain

## Main Pipeline

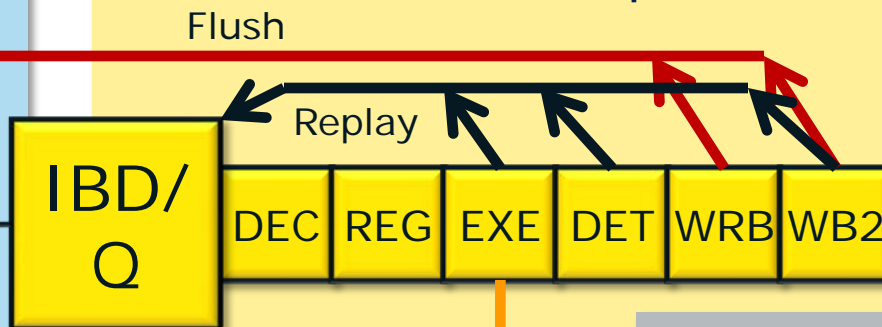

IBD: Instr Buffer/Dispersal  
 DEC: Instr Decode  
 REG: Register Read  
 EXE: Execute  
 DET: Exception Detect  
 WRB: Write-back  
 WB2: Commit

Q holds 96 instructions  
 In-order issue

Independent thread domain

## MLD Pipeline



MLD: Mid-level data cache  
 OZO: Architectural memory  
 ordering queue

OZO holds 16 memory ops  
 OOO issue

Independent thread domain

## Concurrency via 3 decoupled pipelines

# Instruction Parallelism

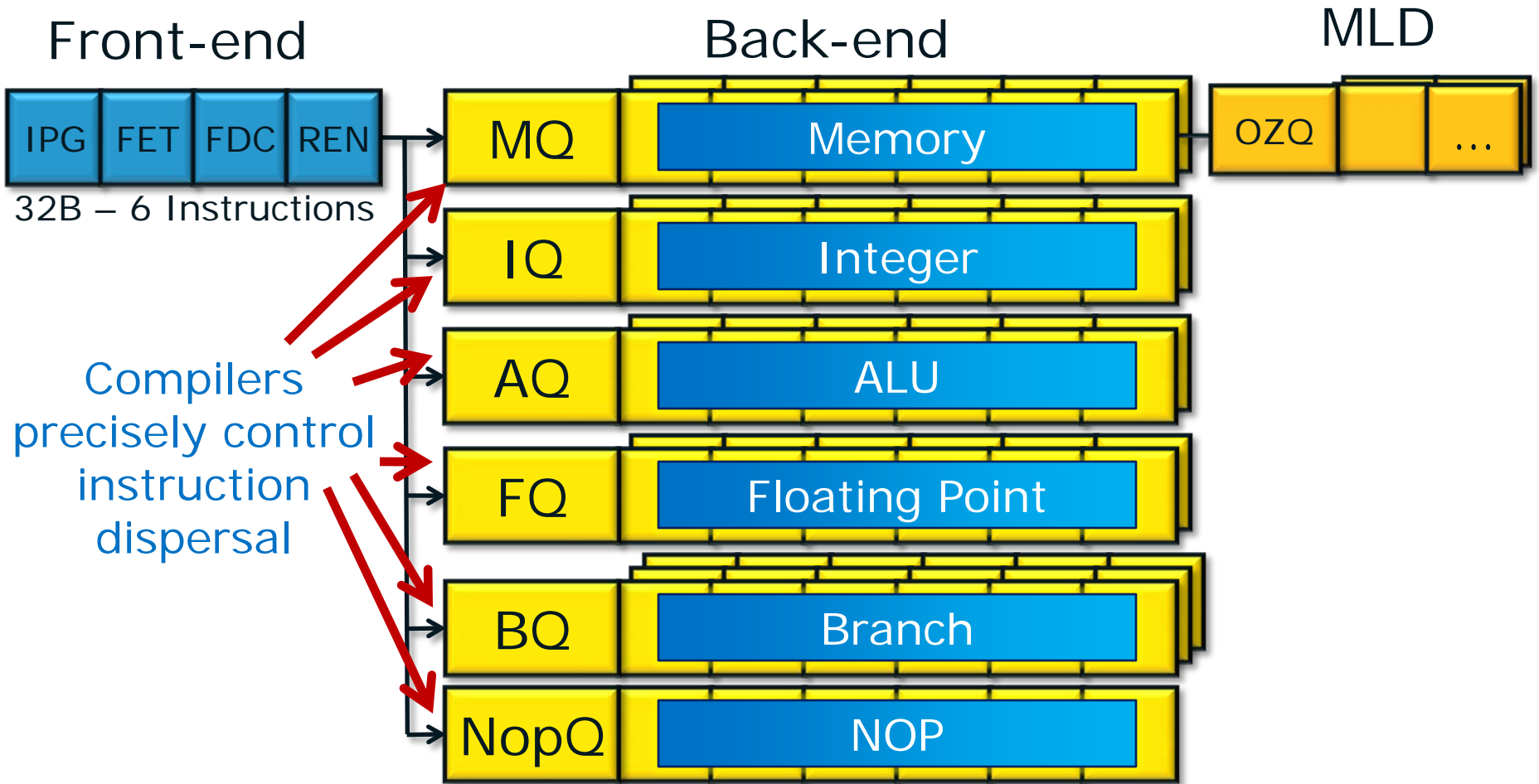

**12-wide issue under software control**

# Memory Parallelism – Avoiding Hazards

## Expanded Software Hints

- Provides control over allocation, speculation and prefetch policies
- Multi-line software prefetch

## Reduced Speculation Costs

- Spontaneous Deferrals on speculative loads
- Deferred load can transform into a prefetch to cache and/or TLB

## New Hardware Prefetcher

- Into FLD and/or MLD
- Adaptive based on FLD/MLD miss patterns

## Reduced Data Hazards

- Expanded store to consumer bypassing in FLD and MLD
- Single-cycle MLD to FLD line transfers

**Pipeline bottlenecks removed**

# Memory Parallelism – Increasing Throughput

More pending memory operations in each core

- Increased from 48 to 64 operations in MLD
- Increased from 44 to 80 operations in Ring interface

Ring Cache

- 8 Independent LLC pipelines and controllers per socket
- 2 caching agents per socket to generate Intel® QPI transactions

Increased Intel® QPI link bandwidth for multi-socket throughput

Memory Subsystem Improvements

- Home agent in-flight transaction tracker increased by 50%
- MC scheduler algorithm changes focused on performance and power efficiency
- Intel® SMI link speed increased

**Improved queuing and B/W**

# Thread Parallelism

Intel® Hyper-Threading Technology with Dual Domain Multithreading support

- Front-end and main pipelines are independently threaded
- Pipeline-specific thread switch mechanisms

More per thread resources

- Instruction queues
- Data TLBs
- Hardware page walker handles concurrent walks to both threads

Instructions provide software hints to thread switch hardware

Attention to Thread Fairness

- Hardware to identify unfair behavior
  - Measures instruction retirement and data cache resource usage
- Firmware configurable responses to unfairness
  - By biasing towards victim thread

**Increased throughput via improved threading**

# Multi-core and Multi-socket Parallelism

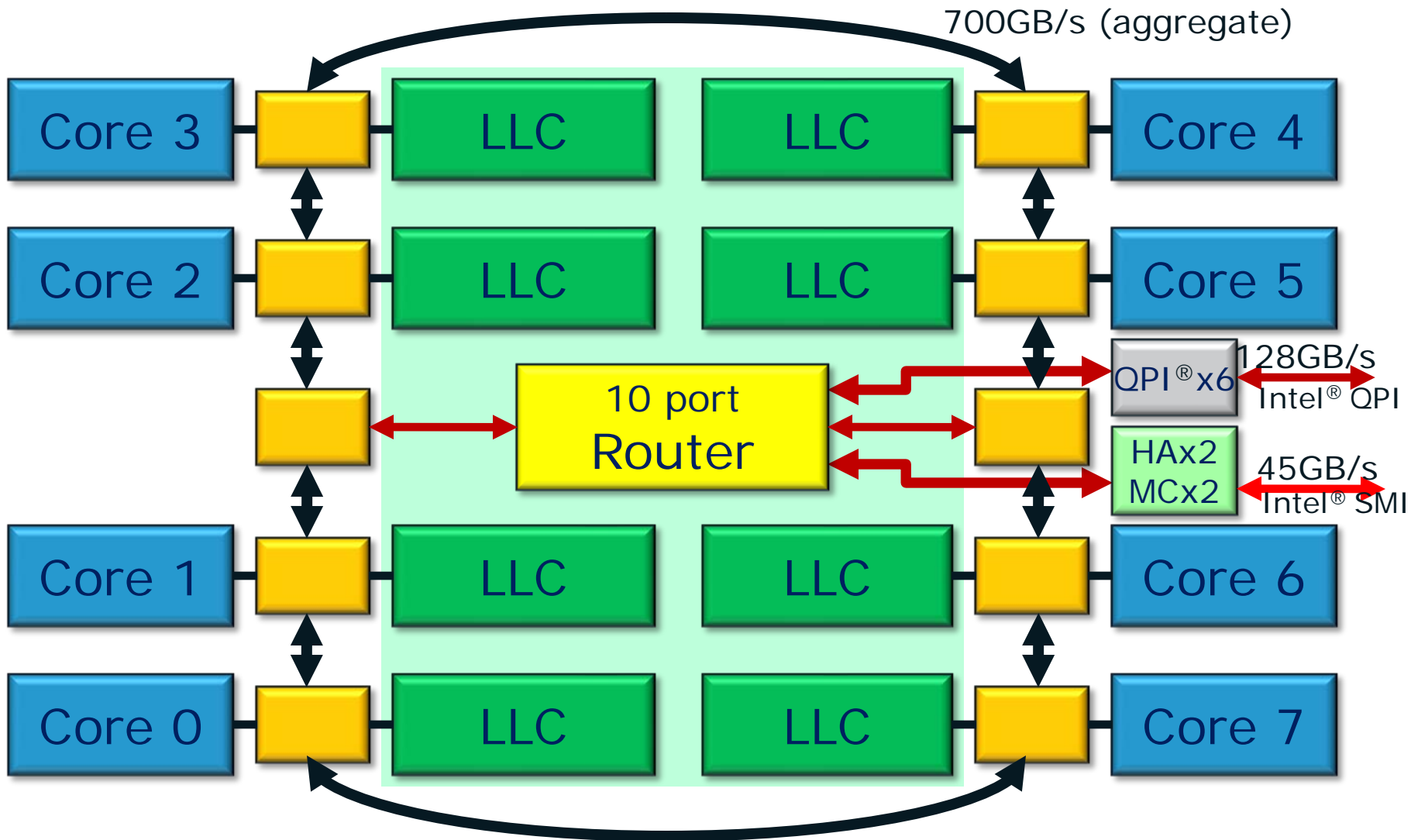

# Reliability, Fault Tolerance and Recoverability

## Intel® Instruction Replay Technology

- Main pipeline redesigned for error handling
- Enabled hardware and firmware recovery of correctable errors

## Increased Error Detection and Correction

- Arrays
  - MLI, MLD, LLC tag and Directory cache – SECDED
  - LLC data – DECTED
  - Register files (GR and FR) – SECDED
- Logic path error detection in FP ALU via residues
- Key paths are protected “end to end” with invalidation and replay

## Reworked Error Detection, Response and Reporting Framework

- Large increase in error detection and response capabilities
- Increased hardware responses and recovery
- Intel® Cache Safe Technology: lockout of failing cache locations

# Power Aware Design

## Replay-based Pipeline

- Enabled fully gated clocks
- Eliminated slow and power-wasting global pipeline stalls

## Aggressive Clock Gating

- Substantial reductions in both idle, typical and max power

## Removed Dynamic Logic from FPU

## Low-Leakage FETs

## Digital Power Prediction

- Measures, weights and averages key core state signals
- Beyond architectural state – uses data patterns
- Estimation error decreased from 35% to 2%

**60% TDP, 70% idle  $C_{dyn}$  reduction  
over process scaled Tukwila**

# Poulson Status

Well into post-Si validation

Booted and being tested on multiple operating systems

Running in many topologies

On track for 2012 shipments

# Conclusion

## All new core design

- 12-wide issue
- Intel® Hyper-Threading Technology with Dual Domain Multithreading
- Itanium® New Instructions and policies for fine-grain software control of hardware parallelism
- Intel® Instruction Replay Technology for frequency, power and fault tolerance
- Core power efficiency: > 3x better than Tukwila<sup>1</sup>

## Ring-based design

- Large last level caches
- High bandwidth system interface

## Outstanding data reliability

- Enhanced error detection
- Improved error recovery
- Better RAS integration

1 – Internal lab measurement

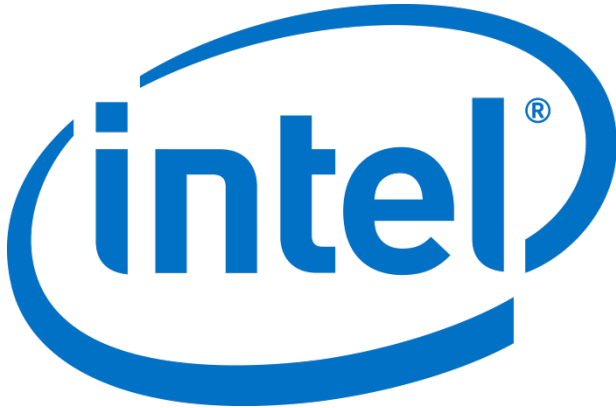

# Glossary

<b>DECTED</b>	Double Error Correction, Triple Error Detection
<b>DTB</b>	Second Level Data TLB
<b>FIT</b>	Failure in Thousands
<b>FLB</b>	First Level Branch Cache
<b>FLD</b>	First Level Data Cache
<b>FLI</b>	First Level Instruction Cache
<b>HA</b>	Home Agent: Intel QPI agent responsible for managing memory
<b>ILP</b>	Instruction Level Parallelism
<b>IPF</b>	Itanium® Processor Family
<b>LLC</b>	Last Level Cache
<b>MC</b>	Memory Controller

<b>MLD</b>	Mid Level Data Cache
<b>MLI</b>	Mid Level Instruction Cache
<b>OZQ</b>	Ordering cZar Queue: architectural memory ordering
<b>QPI</b>	Intel® QuickPath Interface
<b>RAS</b>	Reliability, Availability and Serviceability
<b>RF</b>	Register File
<b>SECTED</b>	Single Error Correction, Double Error Detection
<b>SMI</b>	Intel® Scalable Memory Interconnect
<b>TDP</b>	Thermal Design Power
<b>TLB</b>	Translation Look-aside Buffer