



Fermi GF100 Graphics Processing Unit (GPU)

Craig M. Wittenbrink,
Emmett Kilgariff, Arjun Prabhu



Acknowledgements



- **We would like to thank Jonah Alben, John Robinson, Mark Daly, Henry Moreton, and the entire Fermi GF100 Development team for success of this project**

Outline

- **GF100 Specifications**
- **GF100 Architecture**
- **Tessellation**
- **Physics**
- **Computational Graphics**
- **Demos**

“GF100”

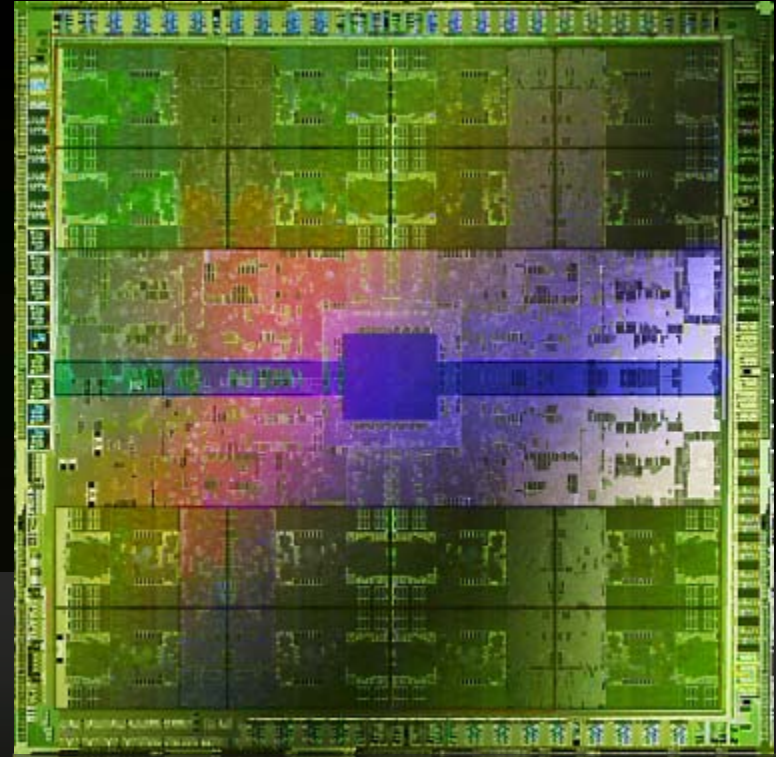

GF100 Specifications



- **3 Billion Transistors in 40 nm process (TSMC)**
- **Up to 512 CUDA / unified shader cores**
- **384-bit GDDR5 memory interface, 6GB capacity**
- **GeForce GTX480: Graphics Enthusiast**
 - **Full Microsoft DirectX 11 Shader Model 5.0**
 - **32x coverage sample antialiasing (AA)**
 - **128-bit floating point high dynamic-range lighting with AA**
- **Tesla C2070: Compute HPC**
 - **CUDA programming: C, C++, OpenCL, DirectCompute, or Fortran**
 - **515 GigaFLOPS double-precision peak floating point**
 - **ECC Register Files, L1/L2 caches, shared memory and DRAM**

GF100 Architecture

- 512 CUDA cores
- 16 PolyMorph Engines
- 4 raster units
- 64 texture units
- 48 ROP units
- 384-bit GDDR5



GF100 SM Architecture

- SM – Streaming Multiprocessor
- 32 CUDA cores: 4x GT200
 - GT200 – previous high-end GPU by NVIDIA
- 48 or 16KB of shared memory: 3x GT200
- 16 or 48KB of L1 cache: No L1 on GT200
- ISA improvements
 - 32-bit integer operations
 - FMA (fused multiply add) IEEE-754 2008
- 4 Texture units
- 1 PolyMorph Engine

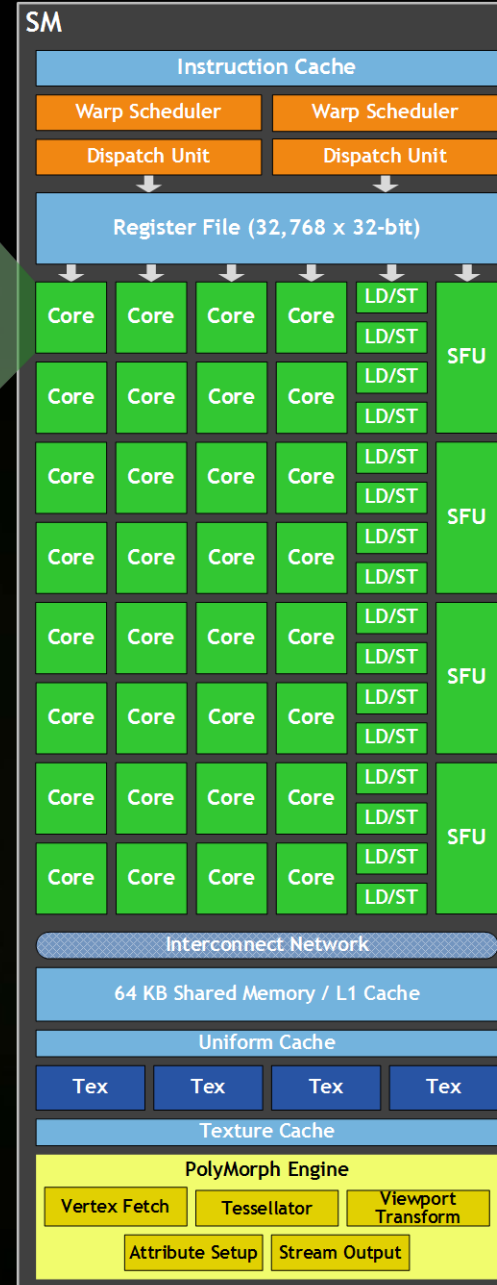
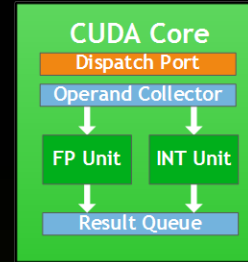

Cache Architecture for Graphics



- **Data stays on die**

- **L1 cache**

- Register spilling
- Stack ops
- Global LD/ST

- **L2 Cache**

- Vertex, SM, Texture and ROP Data

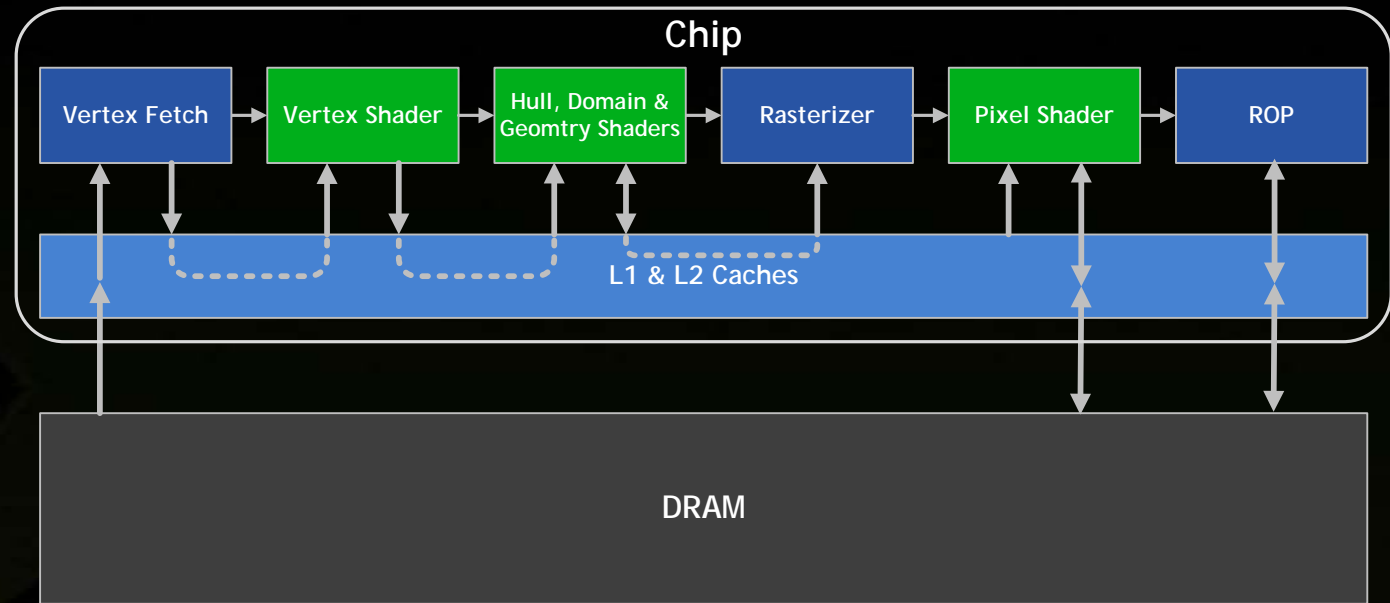

Cache Architecture Comparison



	GT200	GF100	Benefit
L1 Texture Cache (per SM)	12 KB	12 KB	Fast texture filtering
Dedicated L1 LD/ST Cache	✗	16 or 48 KB	Efficient physics and ray tracing
Total Shared Memory	16KB	16 or 48 KB	More data reuse among threads
L2 Cache	256KB (TEX read only)	768 KB (all clients read/write)	Greater texture coverage, robust compute performance

DX10 Game Problems, too little detail



- **Geometry throughput is challenge**
 - Flat head
- **Silhouette results from coarse triangulation**
- **There are other artifacts**



Image from Far Cry® 2,
courtesy of Ubisoft



Offline Film Rendering uses Tessellation

- Tessellation + displacement mapping modelling standard
- Rich geometric detail
- More Geometry, Takes More time



© Disney Enterprises, Inc. and Jerry Bruckheimer, Inc.
All rights reserved. Image courtesy Industrial Light & Magic.

Tessellation & Displacement Maps



Add Geometric Detail

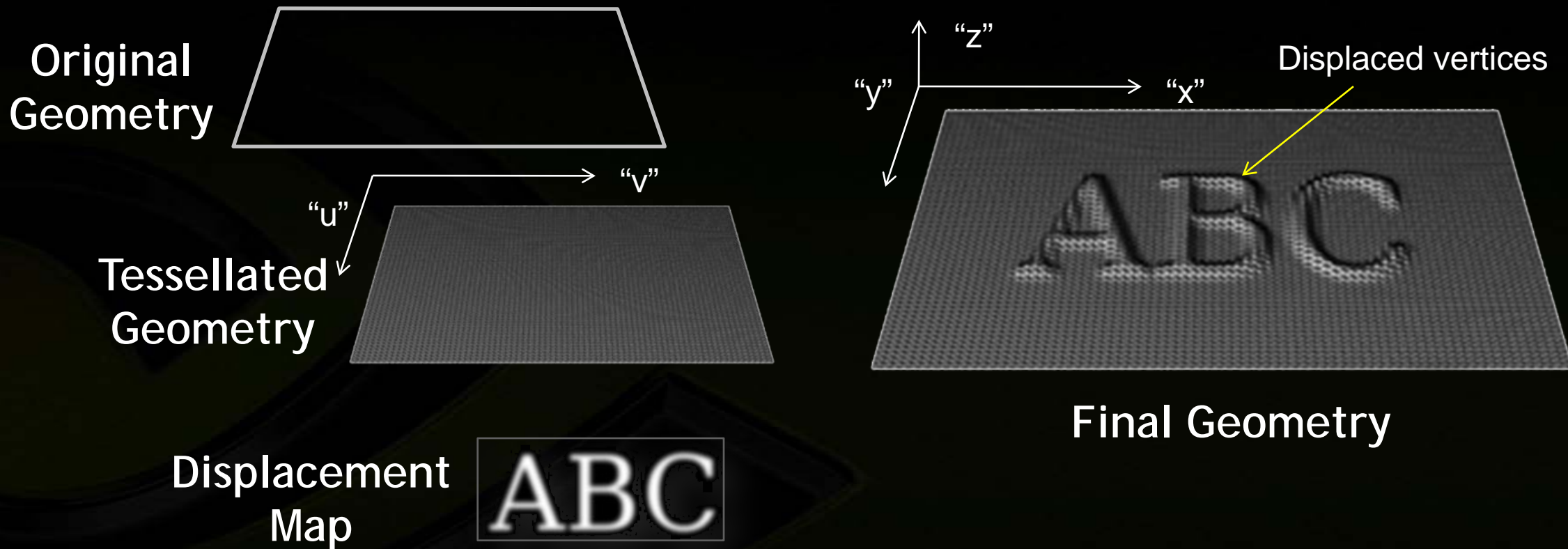

Tessellation in DirectX 11

- **Hull shader**
 - input new patch primitive
 - Outputs tessFactors, modes
 - Runs pre-expansion (1 arrow)
- **Fixed function tessellation stage**
 - input TessFactors and modes
 - Outputs triangles and lines
 - On chip data expansion (3 arrows)

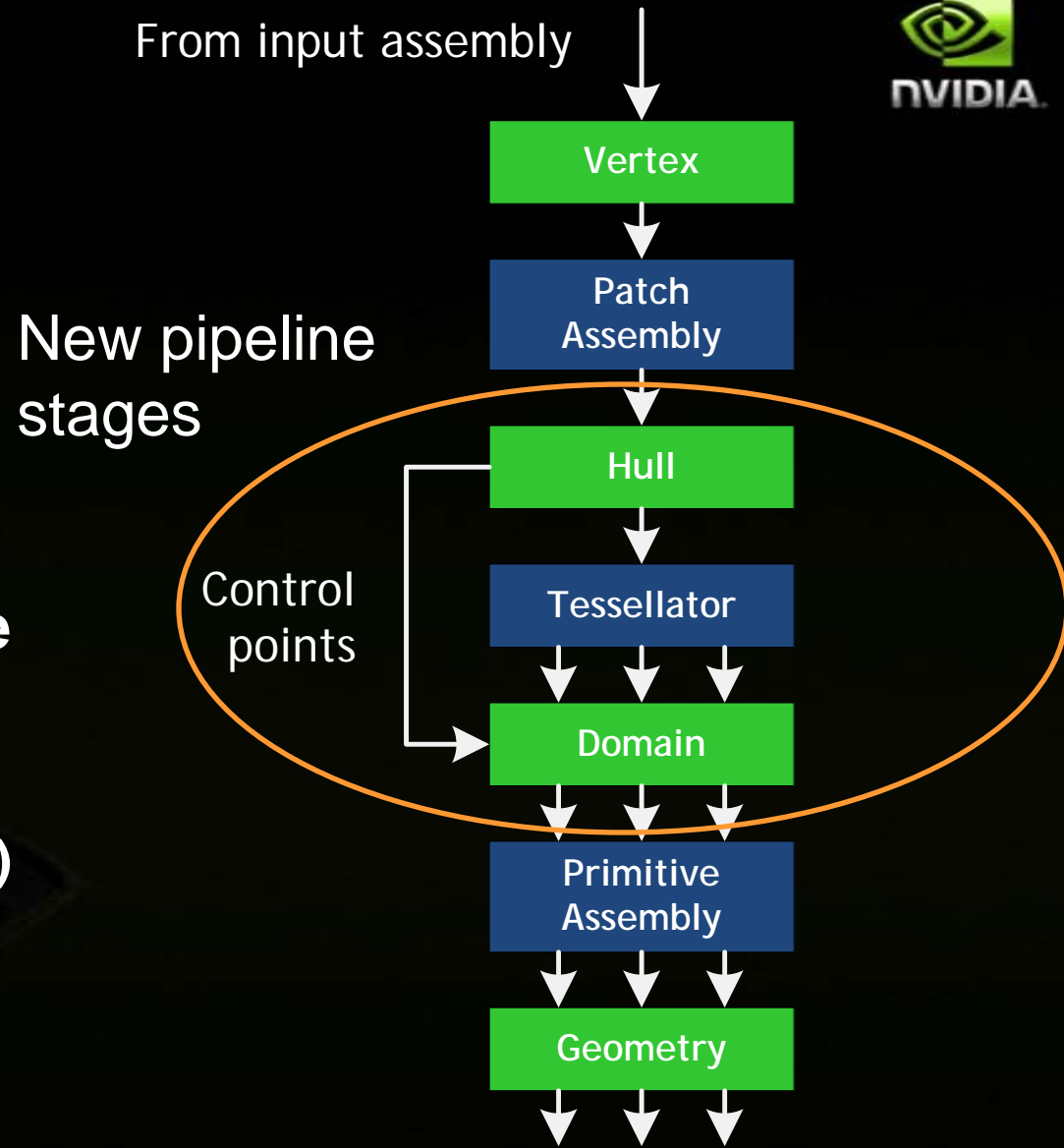

Tessellation in DirectX 11, cont



- **Domain shader**

- **Input TessFactors, (u,v) domain points**
- **Outputs vertices in (x,y,z,w)**

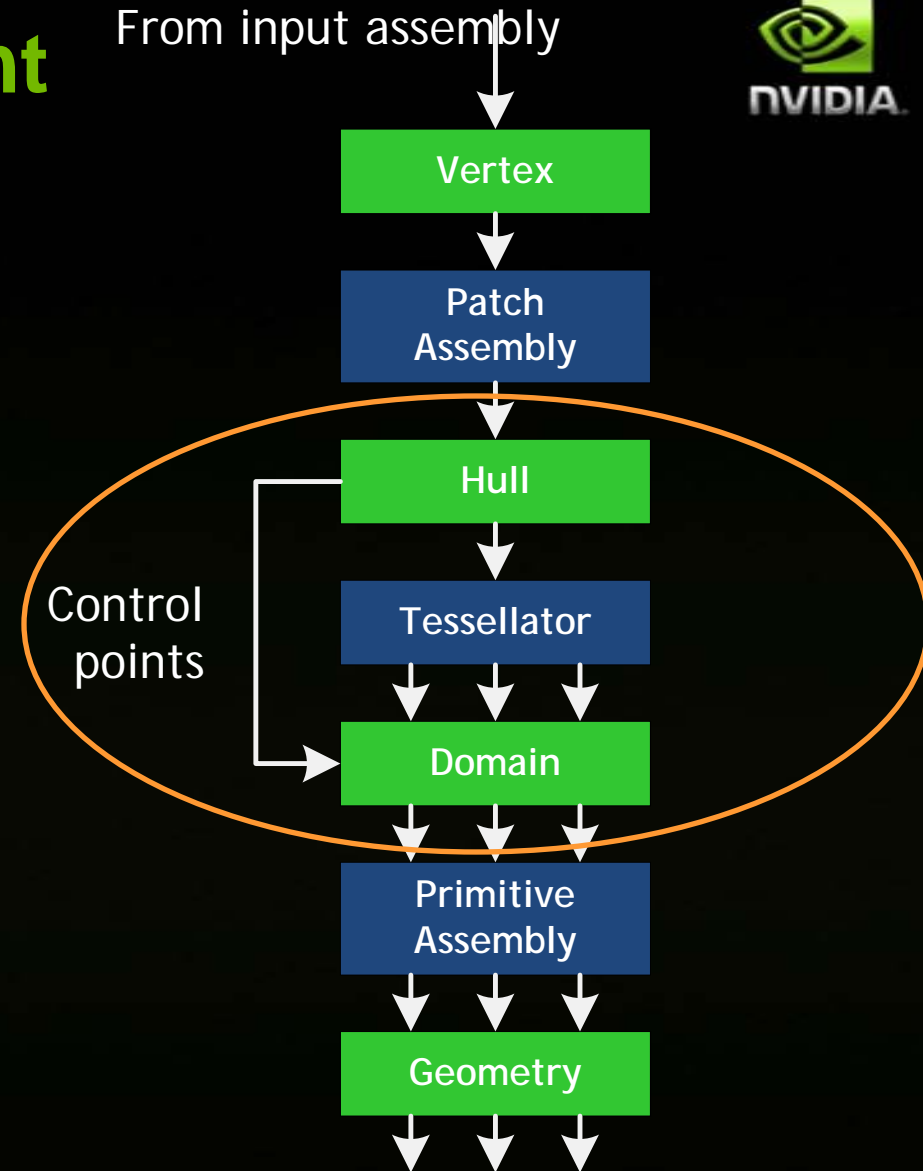
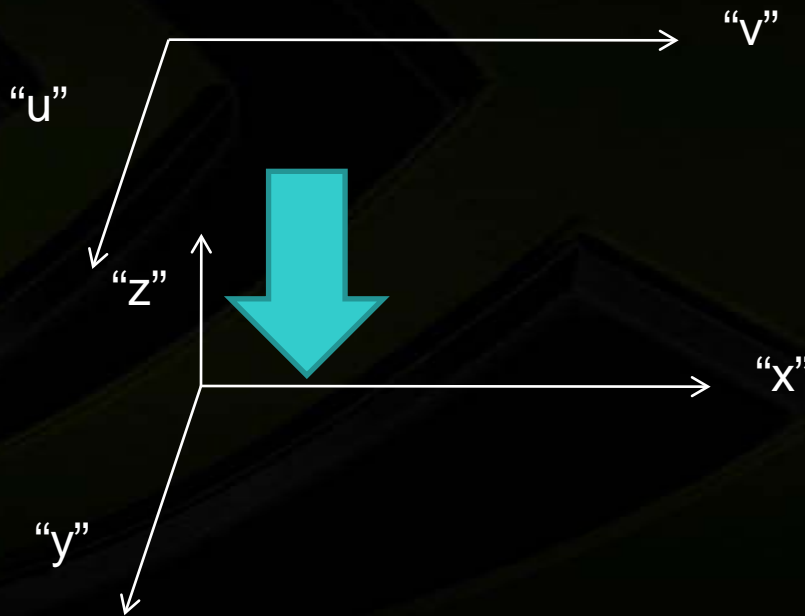

GF100 Scalable Parallel Implementation

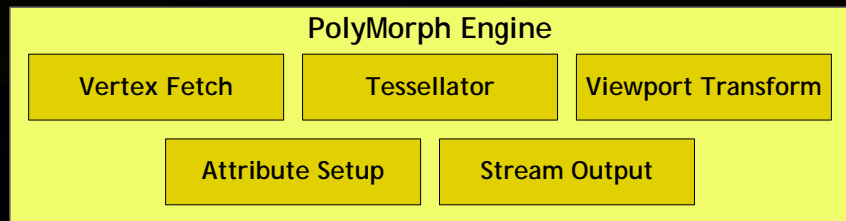
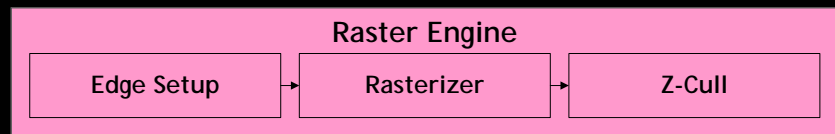

Distributed, parallel geometry
4 Raster Engines
16 PolyMorph Engines

8x geometry performance
vs. GT200

Enables > 2.5 triangles/clock



GF100 Enables Geometric Realism



- **Tessellation provides interactive smooth silhouette**
 - Film like capabilities in games
- **More geometry detail—3D Stereo viewing benefits**
 - Dynamic shadows
 - 3D Vision™
- **Memory footprint & BW savings**
 - Store coarse geometry, expand on-demand
 - Enables more complex animations
- **Scalability**
 - Dynamic LOD allows for performance/quality tradeoffs
 - Scale into the future – resolution, compute power



Dramatic Increase in Geometry Capability

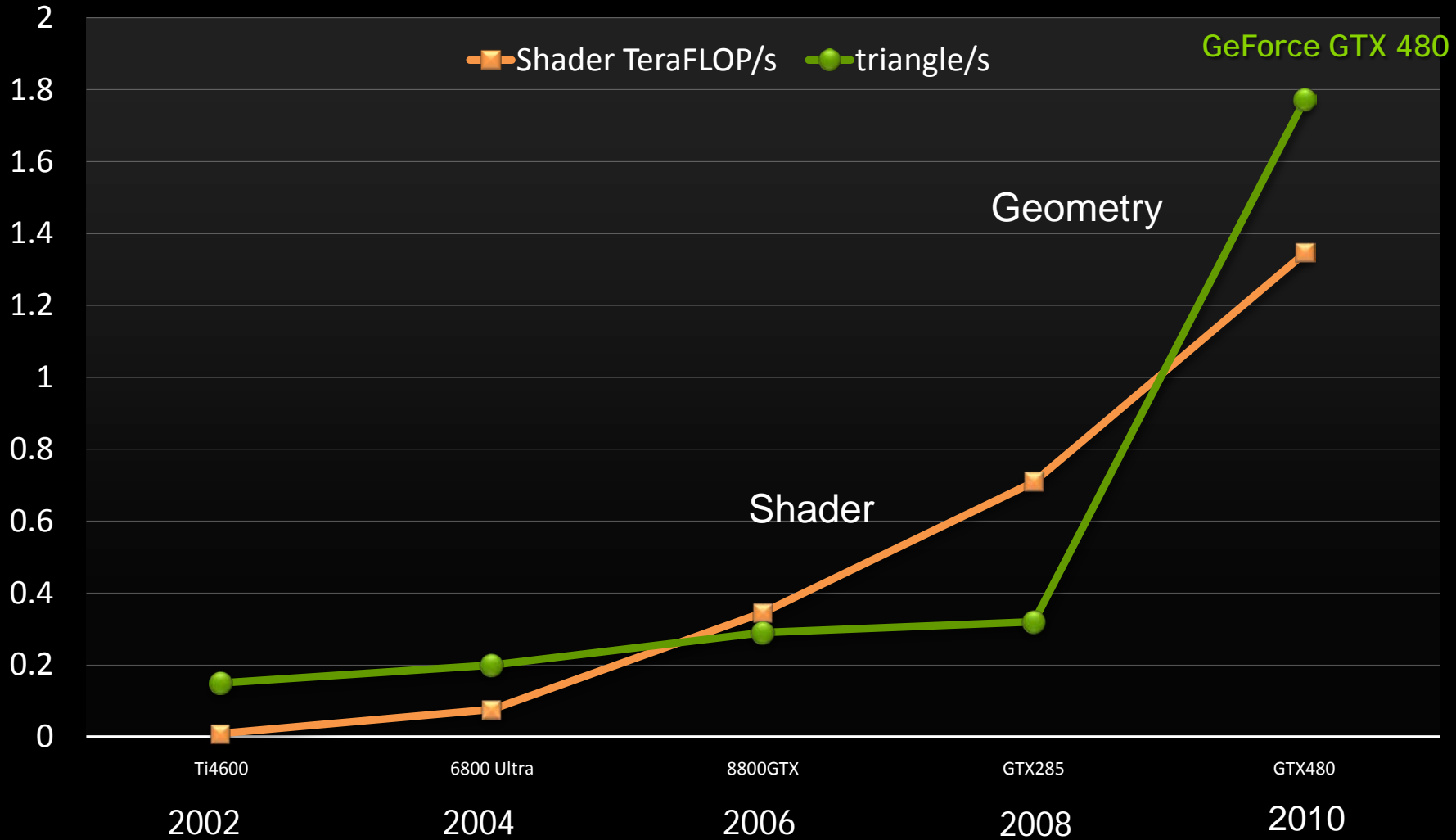

Advance in Geometric Complexity

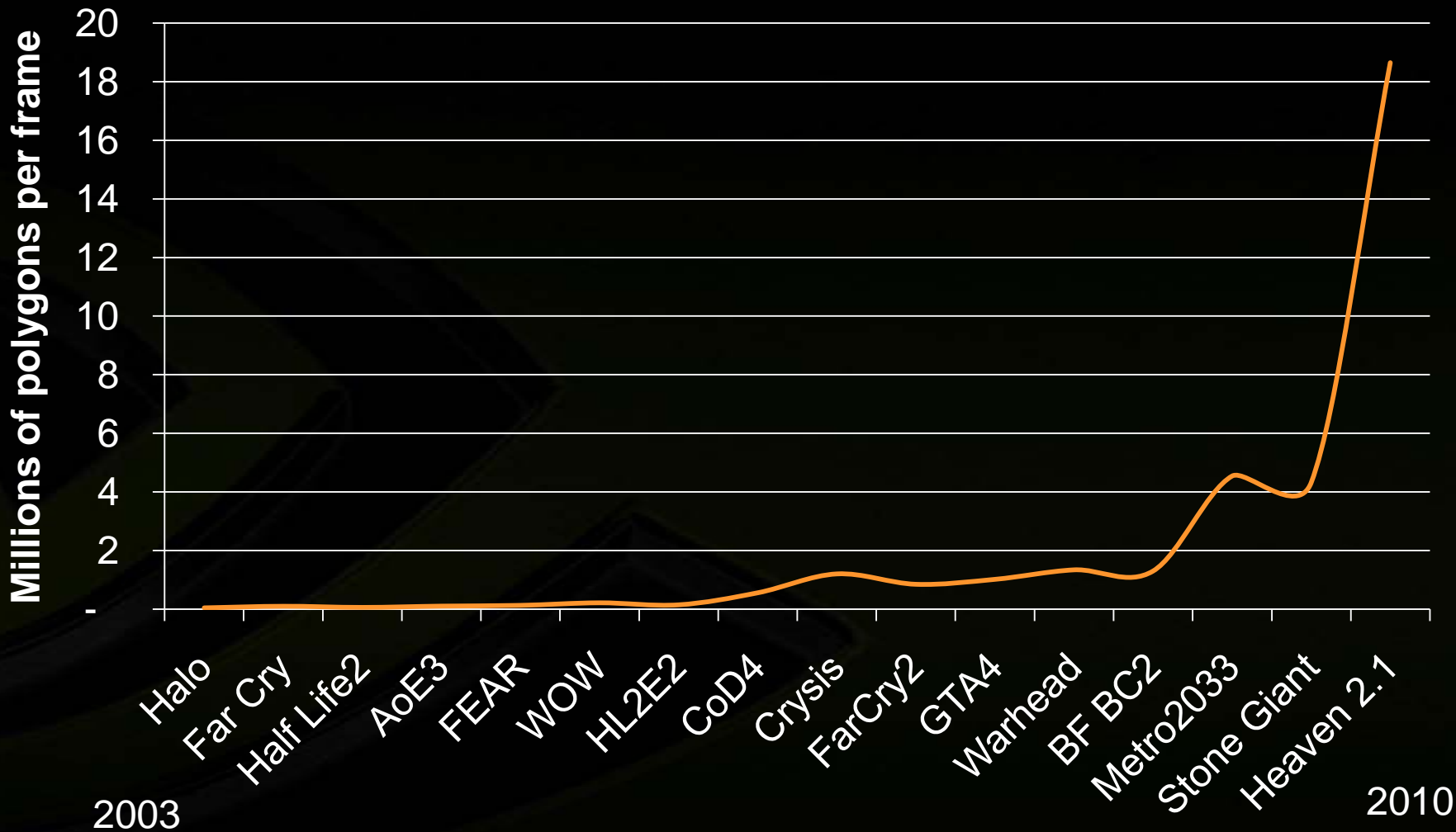

Physics: PhysX[®] Example: Fluid Simulation



- **PhysX[®] is NVIDIA physics engine**
 - Uses CUDA SW stack
 - Used in over 150 computer games
- **Particle-based fluid simulation (SPH)**
 - 128,000 particles
 - Includes surface tension
- **3x speed up going from GT200 to GF100**
 - 67 to 200 fps
- **Games fluid for water splashes, mud, blood...**

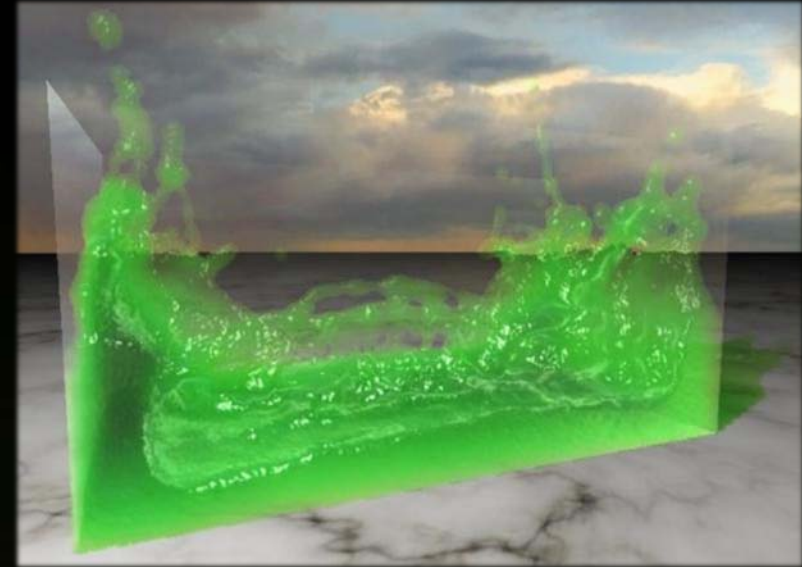

Computational Graphics: Image Processing – Motion Blur

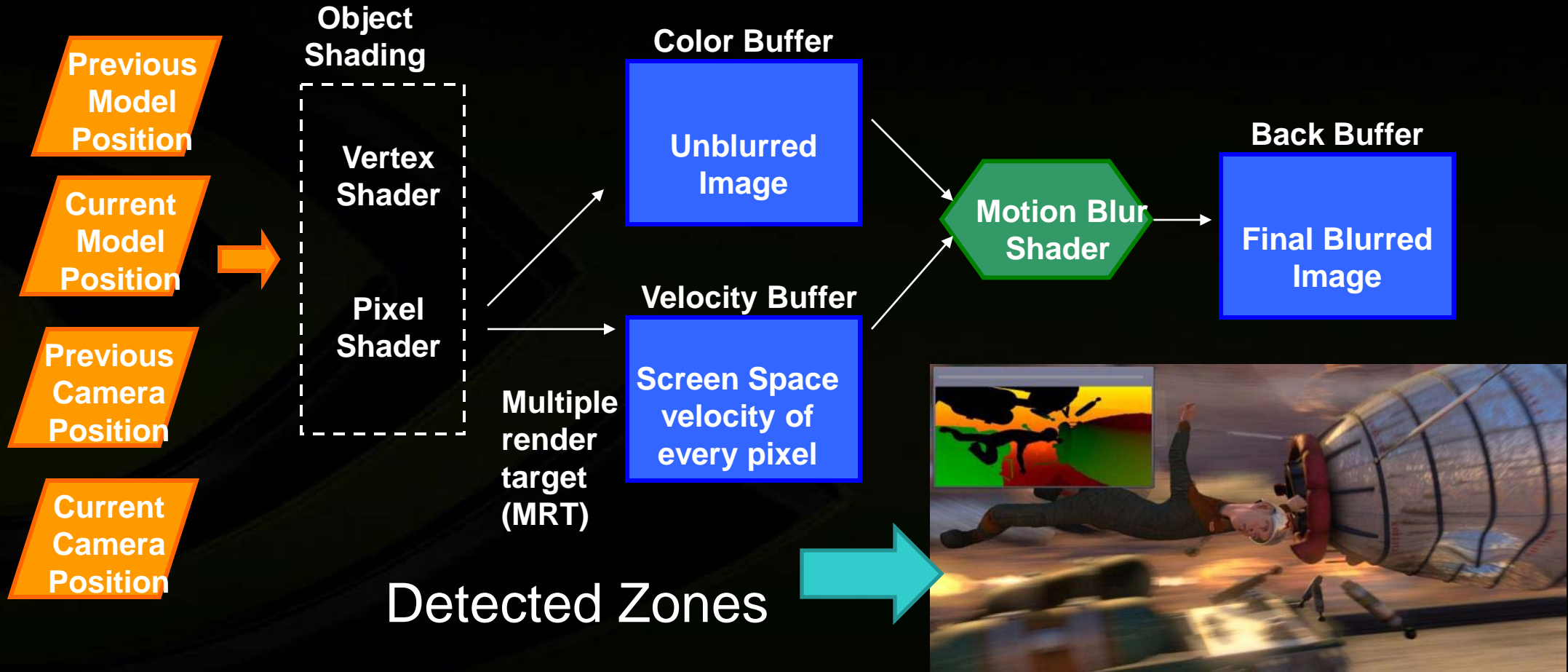

Computational Graphics: Ray Tracing



- **Combine Rasterization with Raytracing**
 - Rasterize primary rays
 - Raytrace shadows and reflections
- **4x faster than GT200**
 - Efficient use of cache architecture



GF100 GPU Compute Performance

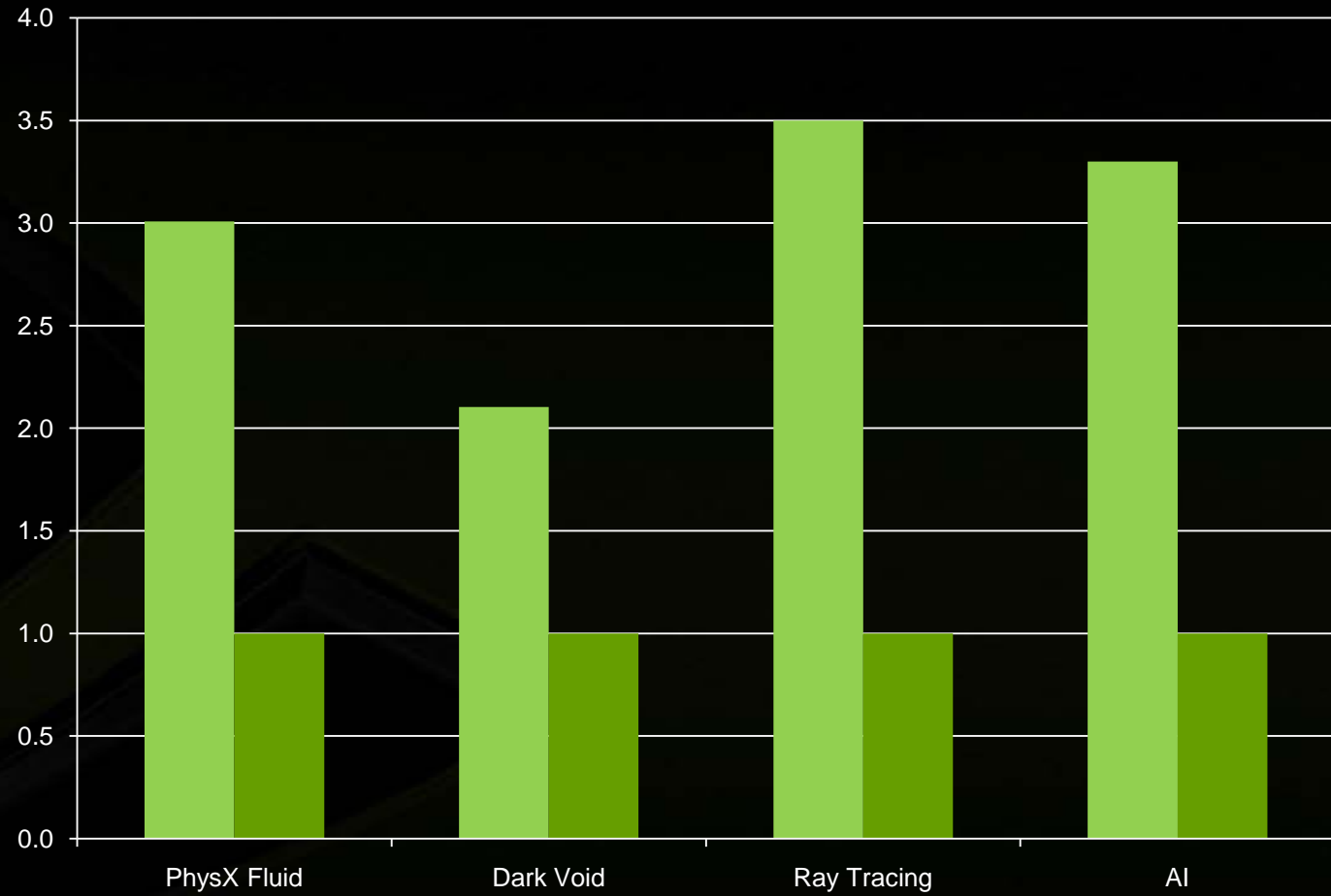
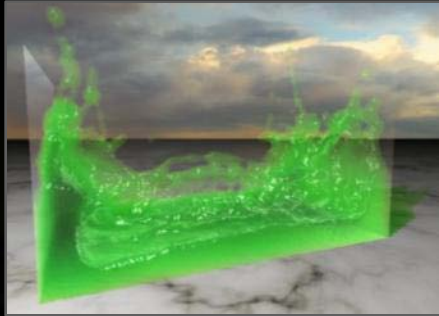

■ GF100
■ GT200

Demo: SuperSonic Sled--tessellation, physics, and computational graphics



SuperSonic Sled: Tessellation - Terrain



Terrain Displacement Map

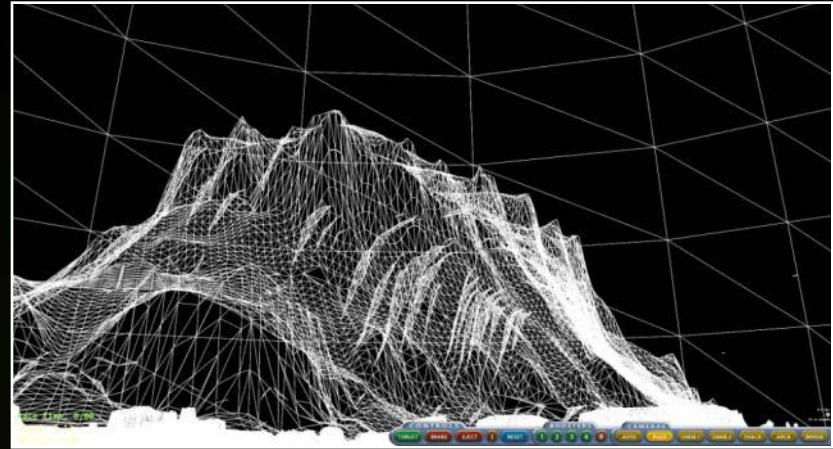

SuperSonic Sled: Physics – Smoke, Bridge, Fireballs

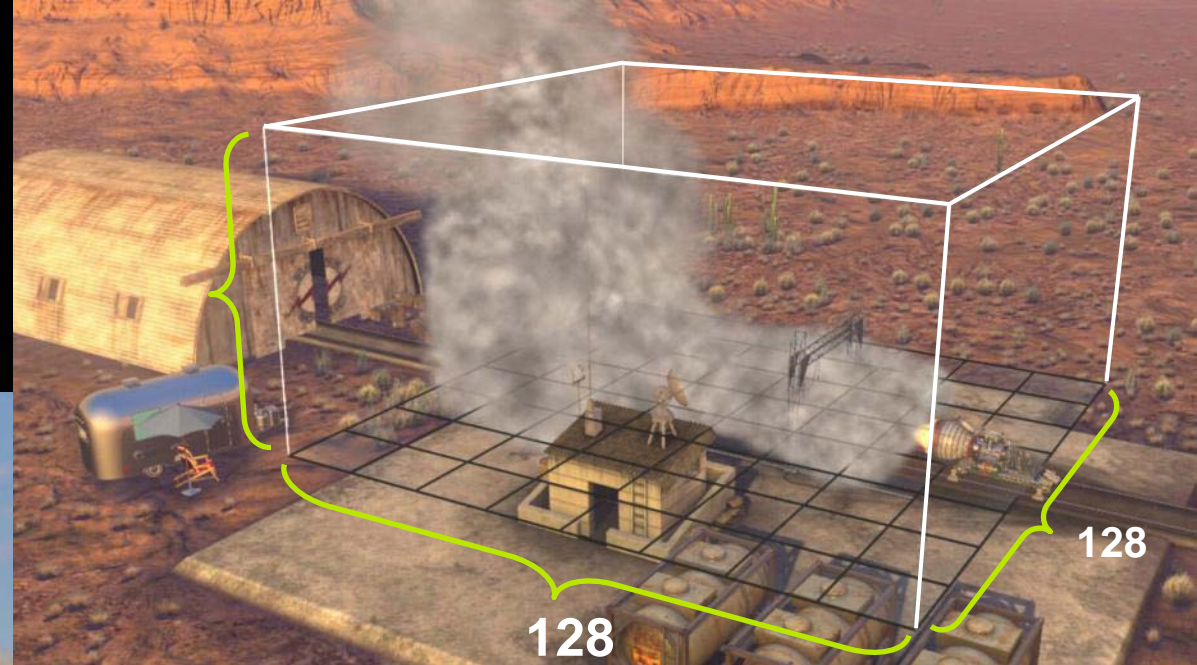
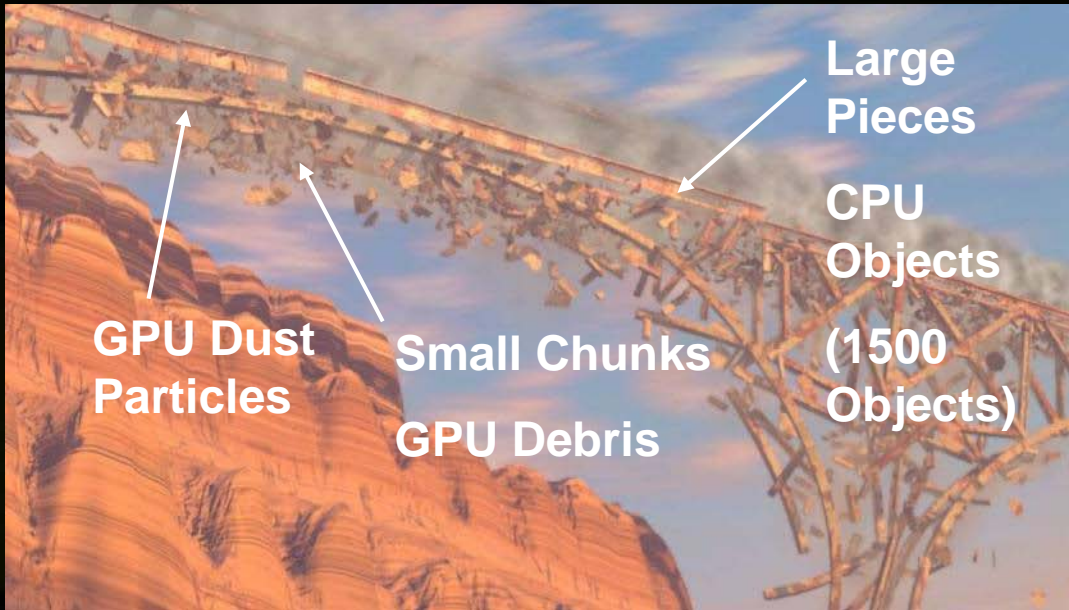

SuperSonic Sled: Computational Graphics- Motion Blur



Demo



Conclusions



- **GF100 Improves Geometry processing up to 8X over GT200**
- **New Architecture and New family of chips**
- **GF100 Architecture breaks 1 triangle per clock barrier**
 - **More than 2.5 Triangles/clock**
 - **High throughput tessellation has benefits for interactive gaming**
- **Demonstration of**
 - **Tessellation**
 - **Physics**
 - **Computational Graphics**