



28nm Generation Programmable Families

7 Series FPGAs

Extensible Processing Platform Family

AMBA AXI4 IP

Brad Taylor
Ralph Wittig

August 8, 2010

Agenda

- **Xilinx 7 Series 28 nm Families**
- **Enhanced Power Efficiency**
- **Enhanced Logic Density**
- **Enhanced IO Bandwidth**
- **Extensible Processing Platform**
- **Advanced Interconnect System**

Xilinx 28nm High Performance Low Power Process

28nm process node

- First wave of 28nm HK/MG devices from fabless Si vendors
- >2x device capacity over 40nm devices
- ~50% total power reduction over 40nm devices

Xilinx 28nm High-Performance, Low-Power process

- High-K Metal Gate (HK/MG)
- Developed by Xilinx and TSMC - optimized for high performance & low power
- 65% lower static power than 28nm variants offering similar performance

Process	Xilinx 40nm High Performance	28nm Low Power	28nm High Performance	28nm High Performance Low Power
Gate Scheme	SiON/Poly	SiON/Poly	HK/MG	HK/MG
VCC	1V	1.05V	.85V	1V
Static Power	>2.5x	1.5x	2x	1.0x
FPGA Performance*	1.0x	0.9x	1.02x	1.0x

* Estimation of FPGA performance based on Xilinx internal benchmark suite

Xilinx 28nm Total Power Reduction

■ New for 28nm – 50% Total Power Reduction from 40 nm

- Static Power - 65% reduction
 - Xilinx High Performance Low Power Process
- Dynamic Power – 25% reduction
 - 40nm => 28nm process shrink
- IO Power – 30% reduction
 - VCCAUX voltage reduction from 2.5V to 1.8V
 - High Speed Transceiver power saving features
 - Single Ended IO (DDR3) power saving features
 - Support for 1.2V, 1.35V for memory standards

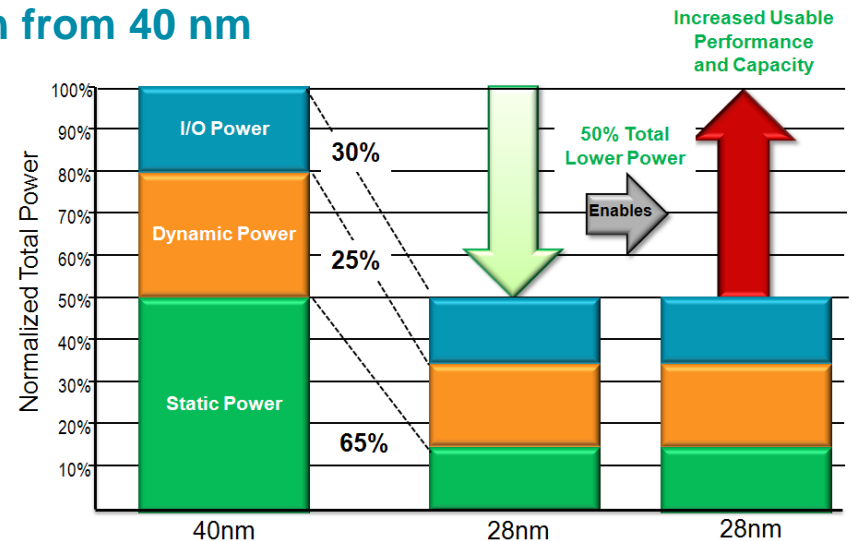

■ Activity Based Logic Optimization – 20% reduction

- Available in ISE v12
- Average 20% savings (benchmark results)
- Leverages clock gating built into Logic Slice

■ Additional Low Power Device Options

- -1L low power .9V speed grades - 20% power reduction

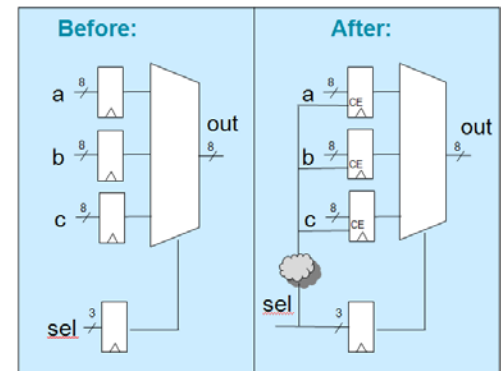

- 1) Total Power reduction estimated from Xilinx internal benchmarks (Range 45%-61%)
- 2) Static power reduction for max VCC, 100 DegC, worst case process

Xilinx Architecture Evolution

- **Unified Architecture Advantages**
 - Rapid deployment of 28nm devices
 - Xilinx IP reuse across all devices
 - FPGA tools optimized for Series 7 architecture
 - 3 families for optimal power, cost, performance
- **1st Step Toward Unification**
 - Virtex-6 and Spartan-6 share compatible 6LUT, DSP48 and IO blocks
- **Two FPGA Base Families**
 - Virtex[®] FPGAs: 4 LUT based high performance, high density family
 - Spartan[®] FPGAs: 4 LUT based low cost family

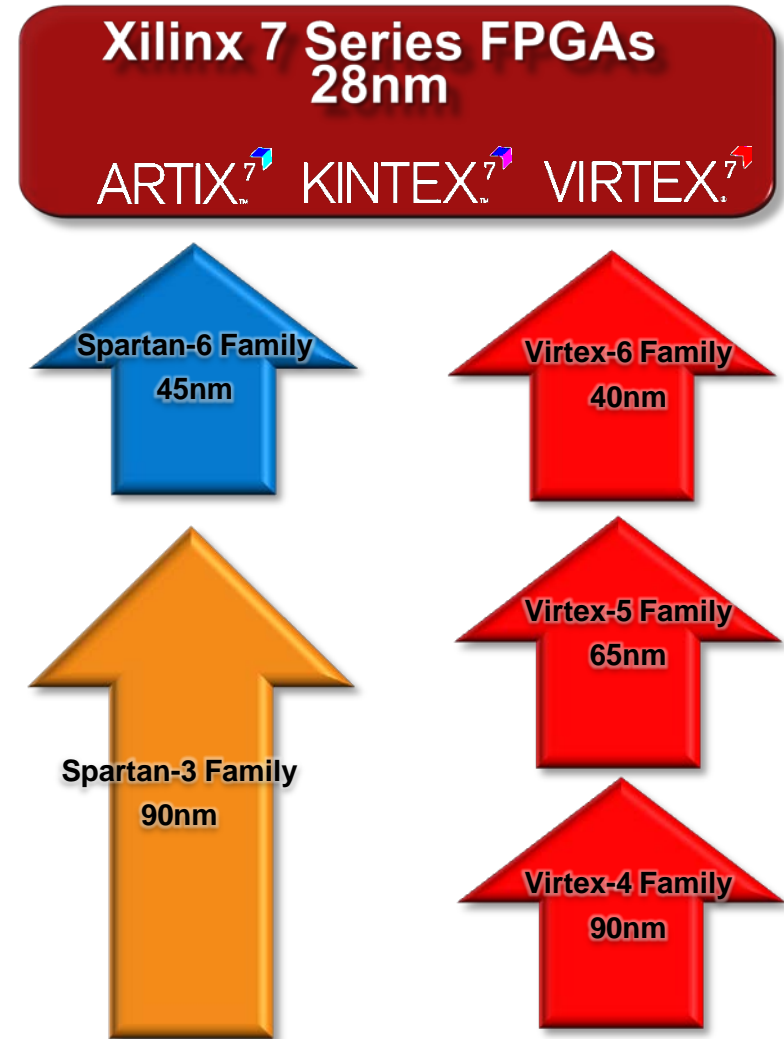

Unified FPGA Family Architecture

ARTIX⁷

KINTEX⁷

VIRTEX⁷

Series 7 Family	Artix	Kintex	Virtex
Market	Lowest Power & Cost	Best Price/Performance	Highest System Performance
Logic Cells	20K - 355K	30K - 410K	285K - 2,000K
Memory Kbits	720 - 12,060 Kbits	2,340 - 28,620 Kbits	14,760 - 64,800 Kbits
DSP Slices	40 - 700	120-1,540	700 - 3,960
Max Transceivers	3.75 Gbps	6.6 Gbps 10.3 Gbps	10.3 Gbps 13.1 Gbps 28.0 Gbps
External Memory Performance	800 Mbps	2,133 Mbps	2,133 Mbps
Max Select IO	450	500	1200
Select IO Voltages	3.3V and below	3.3V and below 1.8V and below	3.3V and below 1.8V and below
Relative Static Power	.5x	1.0x	1.0x
Relative Performance	.65x	1.0x	1.0x

More than Moore

■ Challenge:

- Frequency scaling is minimal
- Performance gains focused on parallelism (= capacity)
- Moore's Law only doubles capacity

■ Solution:

- New packaging & assembly methodology

■ Result:

- > 2x capacity gains over 40nm devices

Family	Capacity Range
Artix-7	20K – 355K LCs
Kintex-7	30K – 410K LCs
Virtex-7	285K – 2,000K LCs

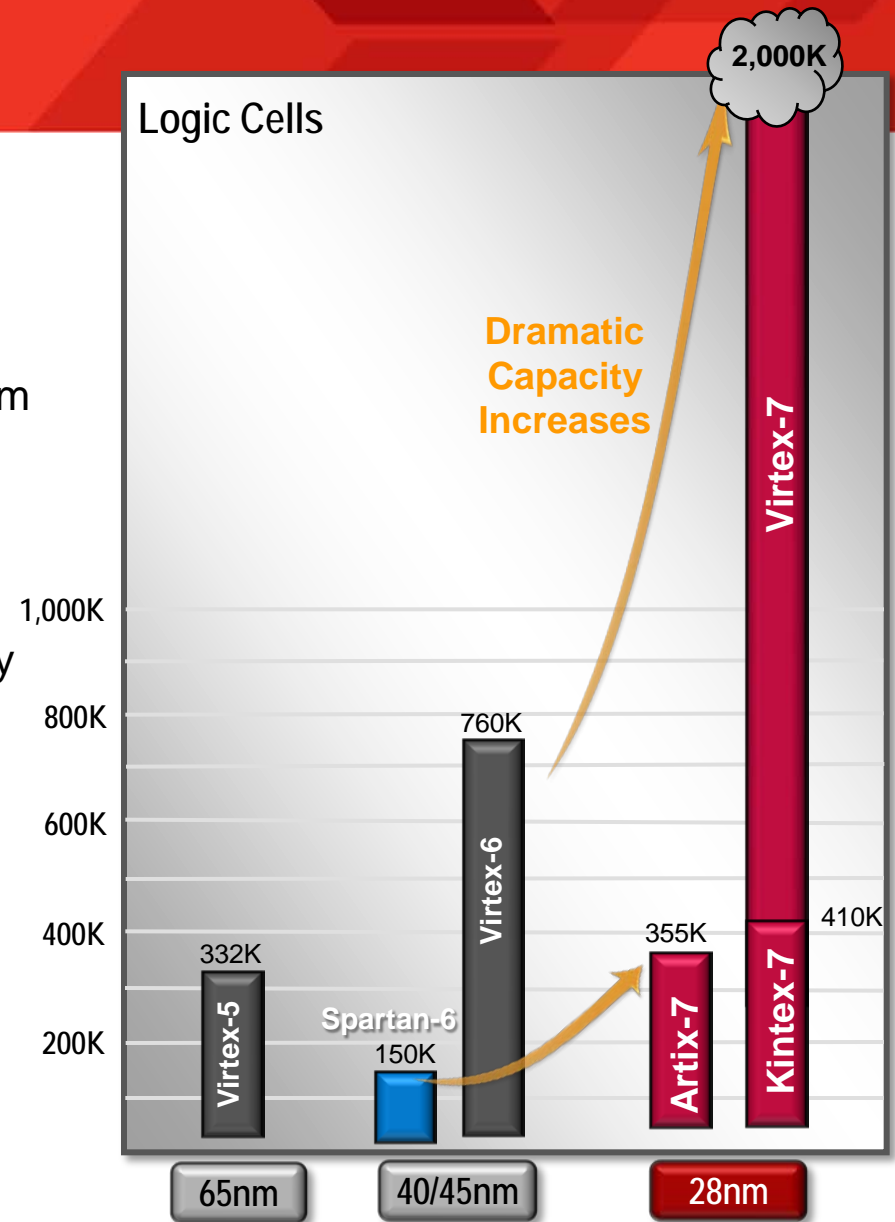

More than Logic

Family Comparisons: RAM, DSP, I/O BW

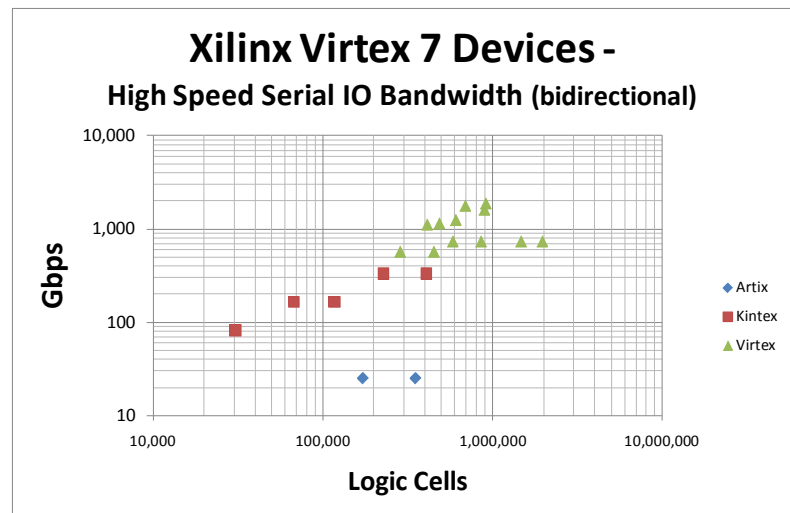
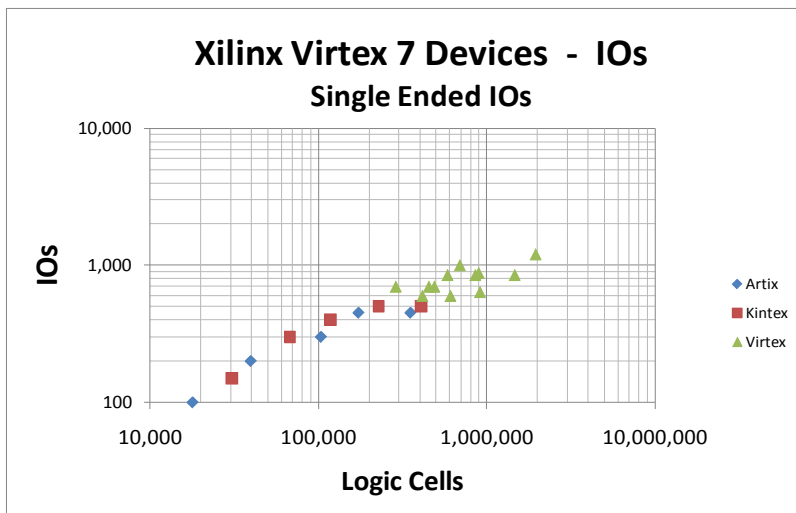
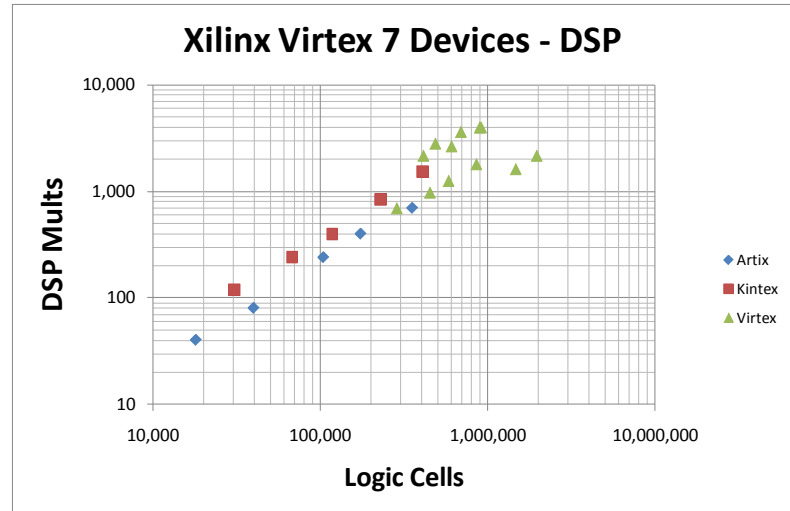
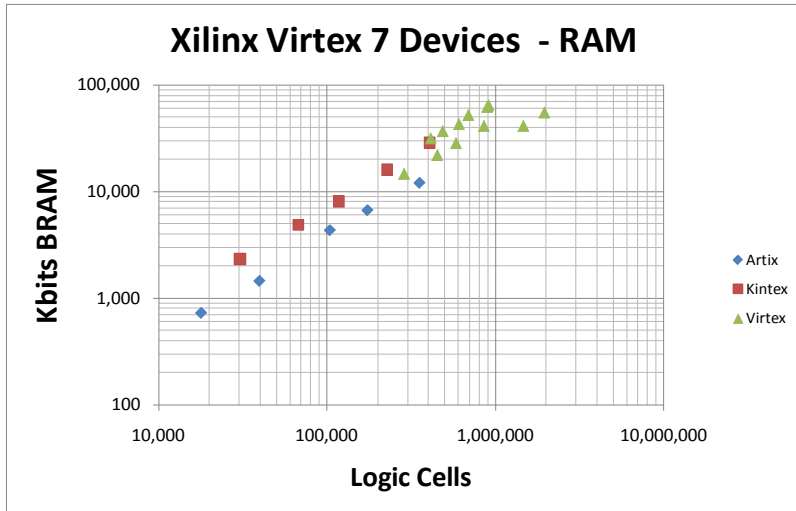

High-Speed Transceiver Evolution

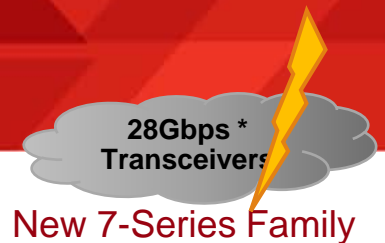

Challenge:

- Increase device BW
- No increase in total device power
- XCVR gains from scaling: negligible

Solution:

- Careful circuit design throughout XCVR
- Increased Gbps / XCVR
- More XCVR / Device
- Low power mode for short channels
- Lanes share a PLL vs PLL per lane

Result:

- 60% Increased max device BW
- Device XCVR power unchanged

	GTP	GTX	GTH	GT28
Max Rate (Gbps)	3.75	10.3125	13.1	28
Relative Power (Per GT)	.35x	.7x	1x	-
Max GTs per Device	4	56	72	-

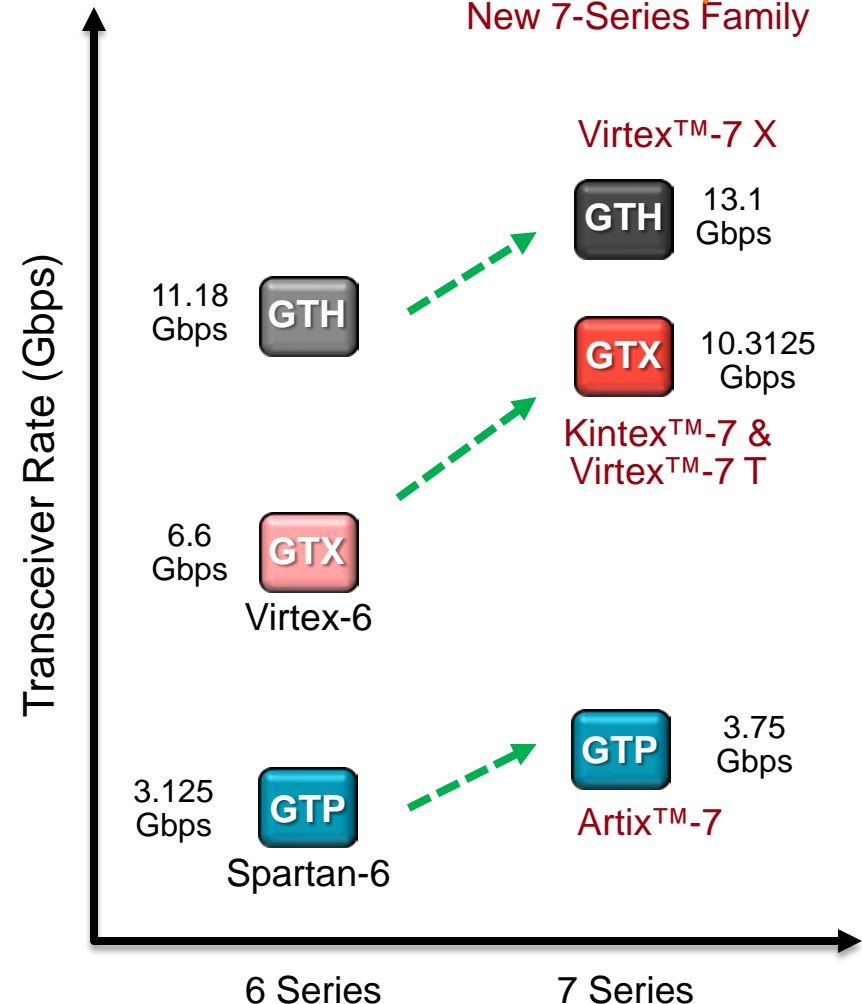

Single Chip 300G Programmable Bridge

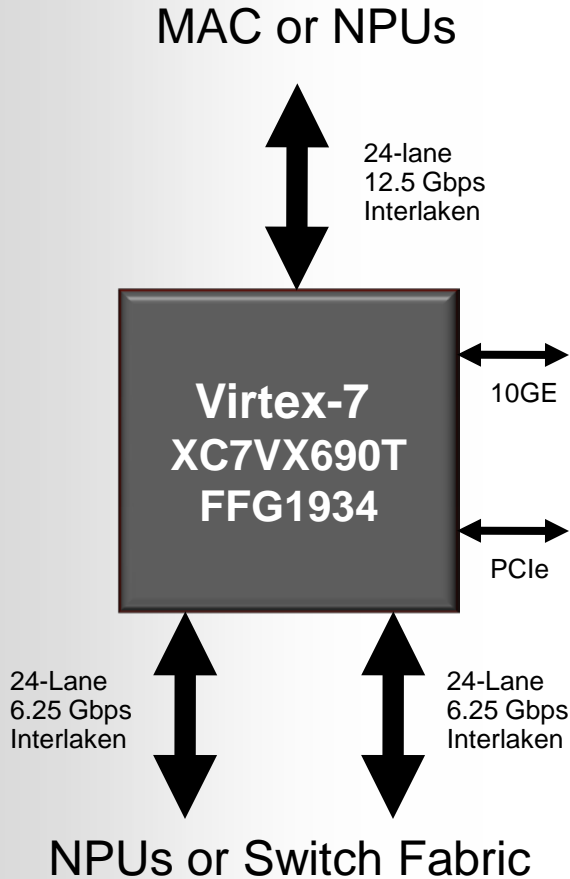

Requirements	ASIC/ASSP	Virtex-7 Single Chip	Theoretical Part w/o Power Optimization
Density	10 Million ASIC Gates	689,920 LC (~10.3 Million ASIC Gates Equivalent)	689,920 Logic (~10.3 Million ASIC Gates Equivalent)
IO Bandwidth	1.2Tbps	1.2Tbps	1.6Tbps
Power	30W	30.4W	42.2W

28% Power Savings Compared to Device without Power Optimizations

Matching ASIC Performance, Bandwidth, and Power

Kintex-7

Balancing Price/Performance

Challenge

- Cost sensitive mid range market segment
- No compromise in fabric performance

Solution

- Same process as Virtex-7
 - ⇒ Same Performance (as Virtex-7)
- Bare die flip chip packages
 - ⇒ 50% reduced cost (vs Virtex-6)

Trade Offs

- Restricted max die size
- Reduced max XVER rate

KINTEX⁷

	Industry's Best Price-Performance
Logic Cells	30K – 410K
DSP Slices	120 – 1,540
Max. Transceivers	16
Transceivers Performance	6.6Gbps 10.3Gbps
Memory Performance	2133Mbps
Max. SelectIO™	500
Select IO Voltages	3.3V and below 1.8V and below

Real World Customer Impact

2x2 LTE Radio

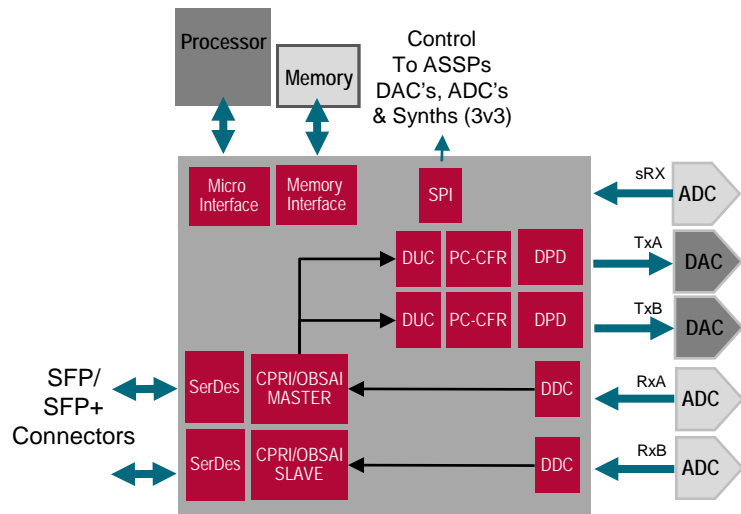

Virtex-6 LX75T

2x2 LTE Radio

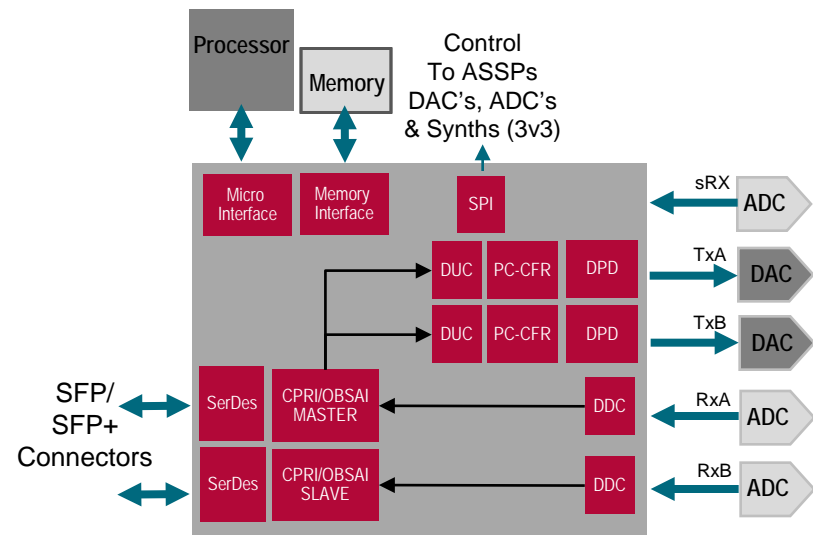

Kintex-7 XC7K70T

Requirements	Virtex-6 LX75T-FF784	Kintex-7 K70T-FBG676
FPGA Cost	1.0	.5
Sys Performance	368MHz	368MHz
Power	8.7W	4.48W

Kintex-7 Performance Upgradable to 491MHz

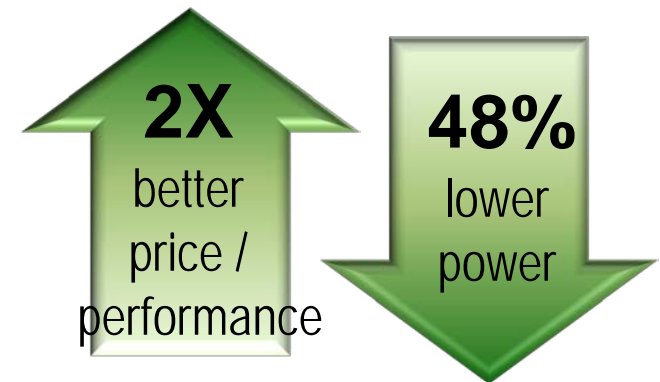

Availability

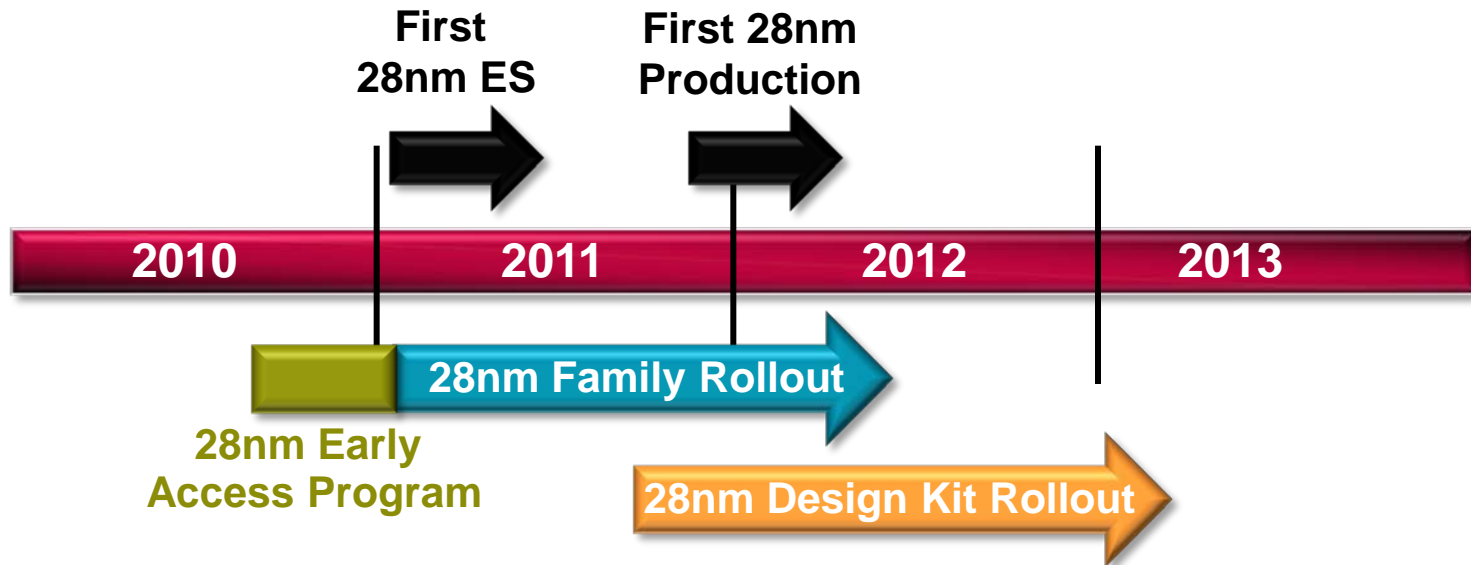

- **Tools available now**
- **First devices in early 2011**
- **Solution kits phasing in in late 2011**

Xilinx EPP

- **Hybrid SOC + FPGA creates *a new product class***
 - Unprecedented configuration compared to an SOC
 - Unprecedented integration compared to an FPGA
- **28nm based product**
- **Significant advantages over a discrete uP + an FPGA**
 - Cost, power, bandwidth and latency
- **Leverages best of ARM and Xilinx Ecosystem**
 - Rich ecosystem of OS, Middleware and Tools support for ARM
 - Tools and IP support for Xilinx FPGA
- **Today: EPP Overview**
- **Future: Detailed family charts, performance numbers, etc**

EPP: An SOC from Xilinx

(Coming from an FPGA company?)

An SOC with an embedded FPGA

- Application level Dual Core ARM A9
- Hard Peripherals
- Cache and Memory
- ASIC-like Cost
- ASIC-like Power
- + 7 Series Programmable Logic

Boots like a Processor

Acts like a Processor

Really ... is a Processor

... and more

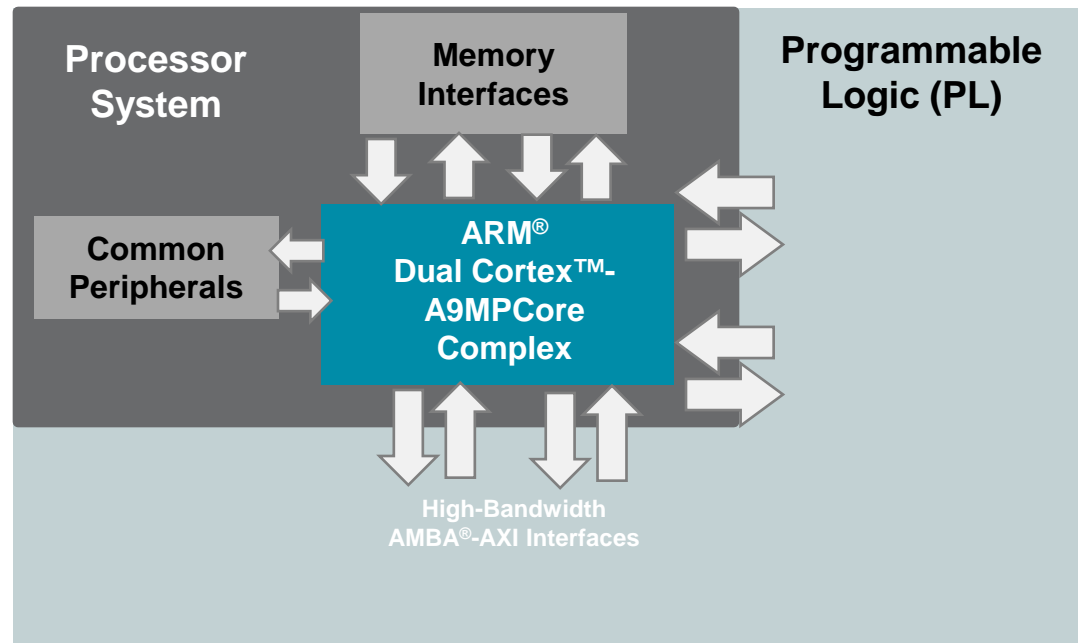

Can you find the FPGA?

EPP: Extensible

(the FPGA value add)

- **Extensible I/O Interfaces**
 - Augment the built-in peripheral set
 - Pre-designed standard peripherals
 - User designed custom peripherals
- **High BW Real Time Processing**
 - Video pipelines
 - Low latency, real time events
- **CPU Offload (accelerators)**
 - Xilinx XtremeDSP functions
 - Custom processing functions
 - Up to 0.2 T MAC/s, Up to 2.8 T (int16)
- **CPU Power Offload**
 - ~10x power reduction per operation
- **Hybrid Many Core**
 - Sea of custom processors in PL*
 - OpenCL like machine

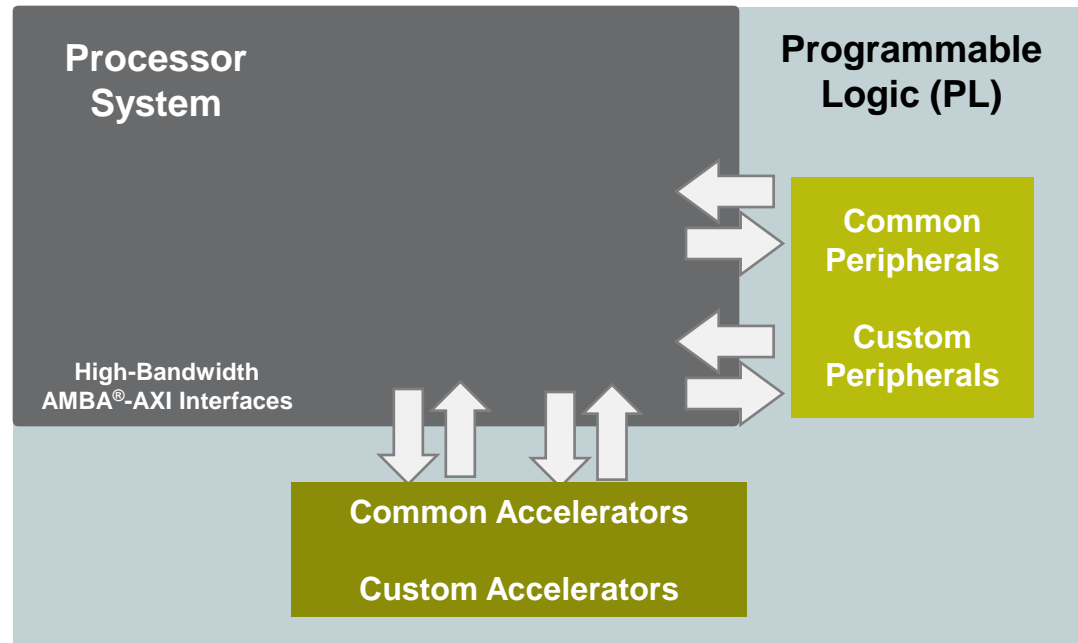

Change the program
Customize I/O interfaces
Add compute accelerators

*PL = Programmable Logic

EPP: Processor System

- **Processor System boots first**
 - Separate power for PL*
 - Peripherals alive before PL configuration
- **Processor controls PL configuration**
 - Multiple security levels supported
 - Boot in secure or non-secure mode
 - Download PL image via network, SD, USB
- **Multiple AXI interfaces to PL**
 - Processor System can access IP in PL
 - PL IP has access to Processor System peripherals and memory system at full BW

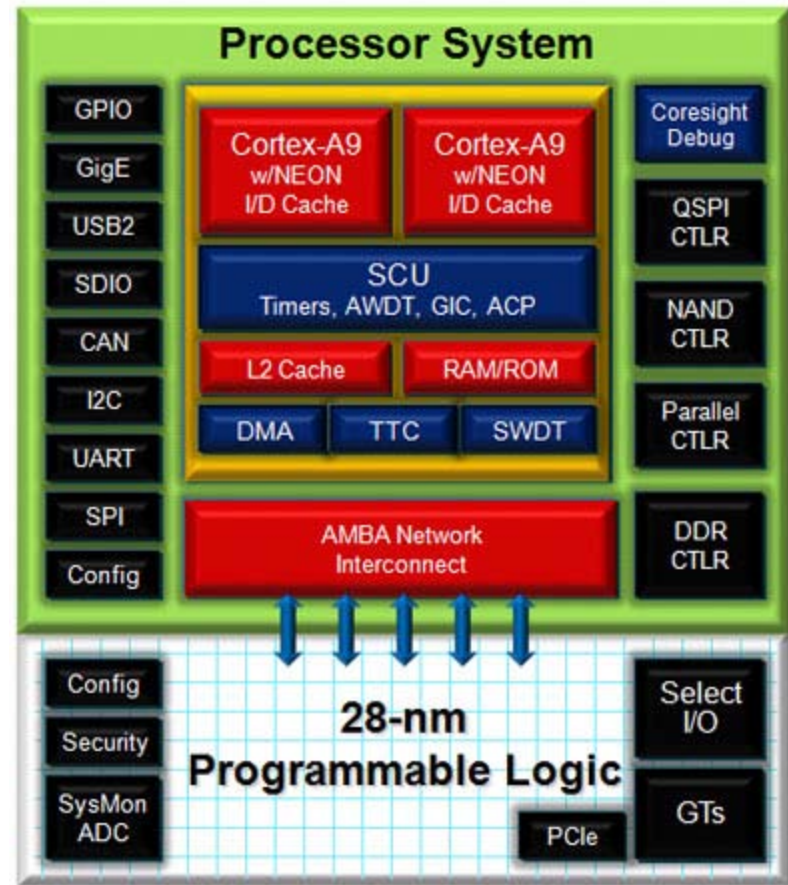

*PL = Programmable Logic

EPP: Programming

- **Out-of-the-box SW programmable**
 - No FPGA design expertise required
- **Standard OS support**
 - Dual core ARM A9 base platform
- **Many Sources of SW and HW IP**
 - Standardized around AMBA-AXI
 - Xilinx, ARM libraries
 - 3rd Parties
- **Industry-Leading Tools**
 - ARM RVDS Suite & Ecosystem
 - Open source GNU tools
 - Xilinx ISE® Design Suite
 - Xilinx Targeted Design Platforms

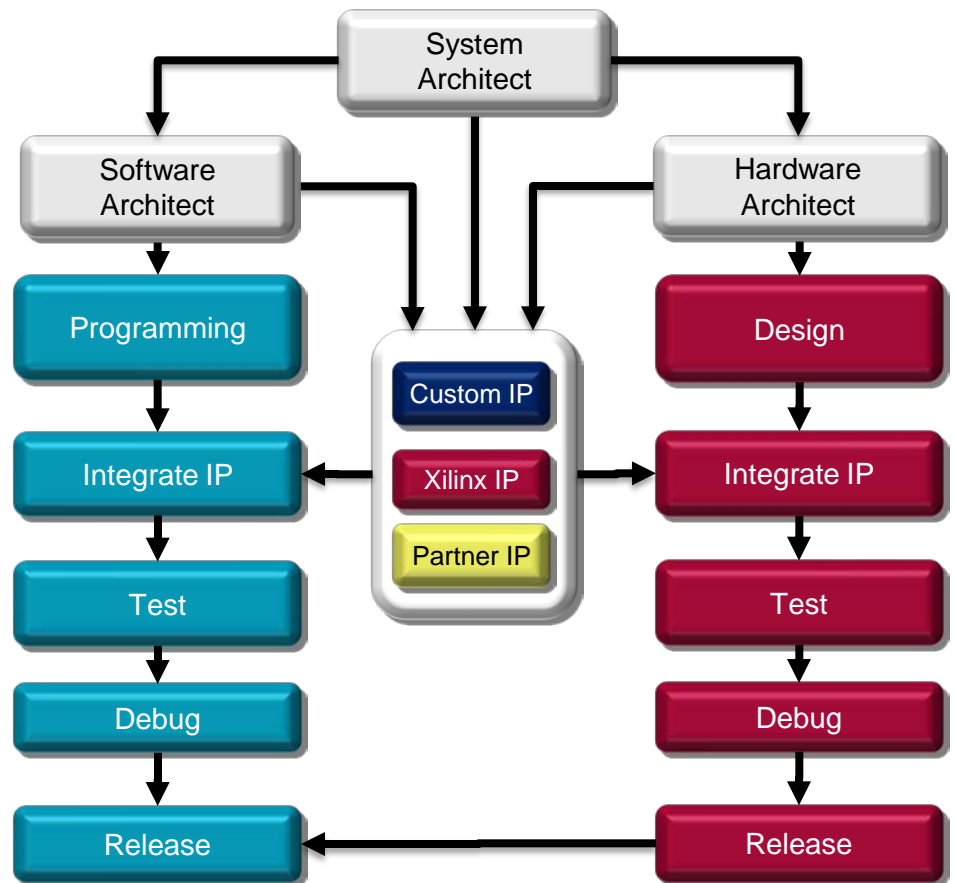

Lessons Learned

Past Experience (8 Years)

- MicroBlaze and PowerPC
- Processor IP and HW Tools
- FPGA design centric

Customer Requests

- Out-of-box programmable
- CPU architecture roadmap
- Open standards
- Ecosystem
- Scalable performance

Xilinx EPP Solution

- Processor-centric approach
- Software-centric approach
- ARM® processing engine
- AXI interface standard
- MicroBlaze continues as soft core solution

*ARM®, AMBA® are Registered Trademarks of ARM Ltd.
PowerPC is a Register Trademark of IBM
MicroBlaze® is a Registered Trademark of Xilinx*

AMBA AXI

(New interconnect standard for all Xilinx IP)

- **Open standard from ARM**

- Well supported, documented and widely adopted
- Broad set of IP available with AXI interface
- Royalty free on any target technology

- **High performance interface**

- Optimized for frequency, throughput, latency and/or area
- Supports pipelining with optional register slice
- QoS controls

- **Easy to use**

- One family of interfaces to learn
- Supports embedded, DSP, and logic users

- **Ecosystem**

- Partners are embracing Xilinx' move to AXI
- Verification IP available
- Widely adopted in the ASIC world

- **New AXI4 interface variants optimal for FPGA**

- Xilinx contributed to specification process

AXI Interconnect Usage

AXI4 interface variants optimized for area and performance

- **AXI4:** Maximizes data throughput for an interface
- **AXI4-Lite:** Area efficient implementation, used for control and status
- **AXI4-Stream:** Easily connect to non-address based peripherals

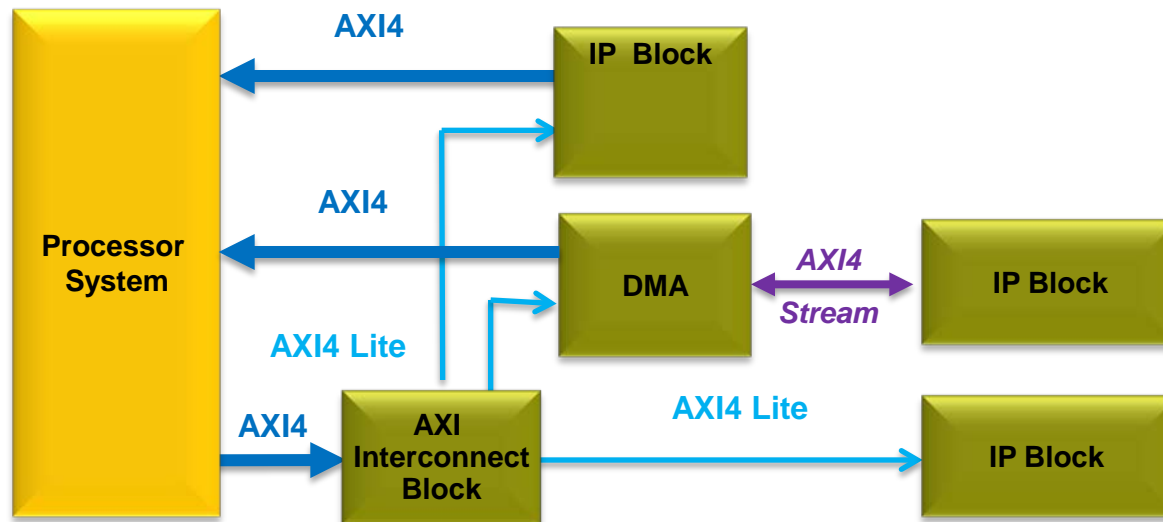

AXI4 Transaction Examples

AXI4 Base Protocol

- Independent read and write interfaces
- Split transaction
 - Address xfer decoupled from data xfer
- Simple READY/VALID handshake
- Data width from 8 to 1024 bits
- Burst size from 1-256 data beats
- Pipelined operation
 - ID tags on each channel
 - Overlapping transactions (reads/writes)
 - Out-of-order completion (reads)
 - Interleaving of data beats (reads)

AXI4-Lite

- Single Transaction only (no burst)

AXI4-Stream

- Write Data Channel only

READY/VALID Handshake

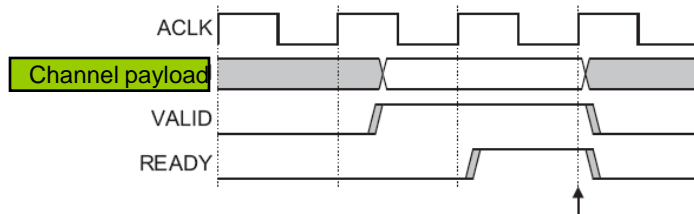

AXI4

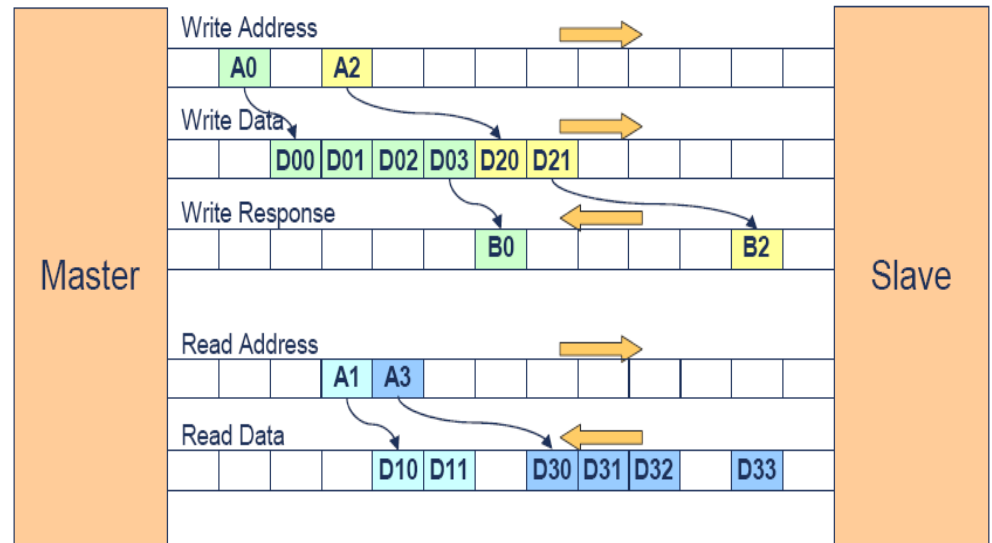

Streaming AXI

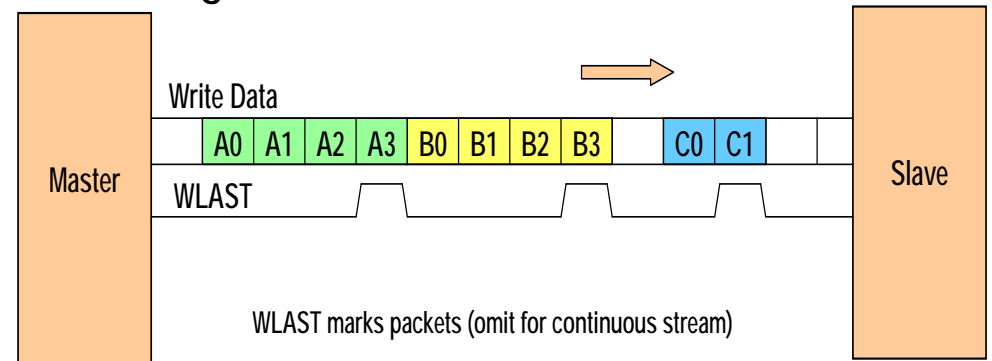

AXI Interconnect IP

(designed by Xilinx, optimized for FPGA)

▪ Crossbar

- Up to 16 masters and 16 slaves per interconnect
- Cascadeable (multi layer switches)
- Independent write and read address arbitration
- Sparse crossbar data path between configured endpoints

▪ Data width, protocol and clock conversion

- 32 to 1024 bit data width (256 bit max at launch)
- Built-in AXI4-Lite and AXI3 protocol conversion
- Asynchronous and integer-ratio clock conversion

▪ Built-in buffering

- Pipeline registers per channel to boost frequency
- Data FIFOs per endpoint for “bursty” throughput

▪ Multiple threads (transaction IDs)

- Read data reordering and interleaving between threads
- Reduces stalling

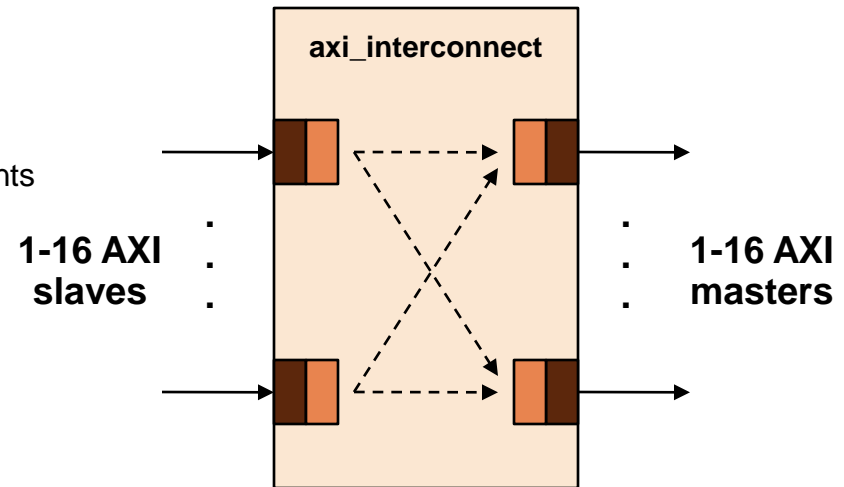

Optional AXI Register Slice/Buffer

- Configurable FIFO depth

Optional AXI Protocol Conversion

- Data Width conversion
- Protocol Bridge
- Integer-Ratio Clock Bridge
- Asynchronous Clock Bridge

Summary

- **Unified device architecture for all 7 Series FPGAs**
 - Scalable platform with three families: cost, power, performance
 - 50% total power reduction
 - Increased capacity and bandwidth
- **Xilinx EPP: SOC with embedded programmable logic array**
 - Boots like a processor
 - SW centric programming model
 - Extensible peripheral set and compute
- **All Xilinx IP (soft and hard) use AMBA AXI interconnect**
 - High performance, scalable interconnect
 - AXI4 is optimized for FPGAs
 - Memory mapped and streaming interfaces
- **Availability**
 - IP with AXI interface: Sept 2010
 - 7 Series FPGAs: First devices in early 2011
 - EPP: To Be Announced



Design Green by Xilinx

References

■ Xilinx 28 nm HPL technology

- http://www.xilinx.com/support/documentation/white_papers/wp312_Next_Gen_28_nm_Overview.pdf

■ Xilinx Series 7 FPGA Families

- <http://www.xilinx.com/technology/roadmap/7-series-fpgas.htm>
- [Series 7 Press Backgrounder](#)

■ Xilinx Extensible Processing Platform

- <http://www.xilinx.com/technology/roadmap/processing-platform.htm>
- <http://www.xilinx.com/publications/archives/xcell/issue71/cover-story.pdf>

■ AMBA-AXI

- <http://www.arm.com/products/system-ip/amba/amba-open-specifications.php>