

Introducing 28-nm Stratix V FPGAs: Built for Bandwidth

Dan Mansur

Sergey Shumarayev

August 2010



Market Dynamics for High-End Systems

Communications



- Mobile Internet driving bandwidth at 50% annualized growth rate
- Fixed footprints
- Existing power ceilings
- 40G/100G system deployment with 400G on the horizon

Broadcast



- Worldwide proliferation of HD/1080p
- Move to digital cinema and 4K2K
- Fixed power budget

Military



- Heightened intelligence and defense needs
- More sensors, higher precision driven to decision points faster
- Power and uptime critical

Computer and Storage



- Higher bandwidth, performance and lower latency
- Power consumption affects total cost of ownership
- Cloud computing driving up bandwidth

Stratix V FPGA Family on 28-nm Process

- Stratix V FPGAs are built on TSMC's high-performance 28-nm HKMG process
 - Optimized for low power
 - ABB with core voltage 0.85V
- Ideal choice for devices used in next-generation, high-bandwidth systems
 - 35% higher performance than alternative process options
 - 30% lower total power versus previous generations
 - Enables fastest and most power-efficient transceivers

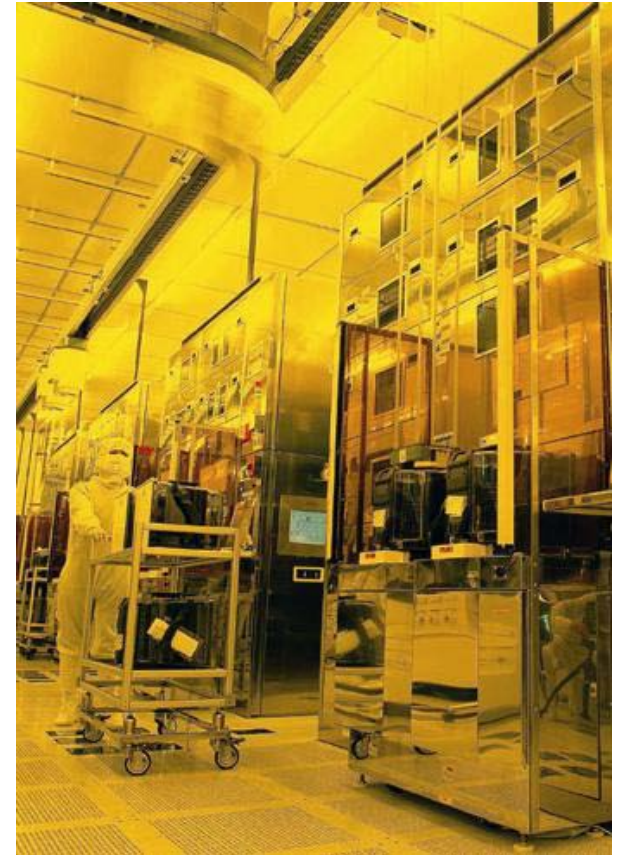

Stratix V FPGAs – Built for Bandwidth

■ Bandwidth

- 66 transceivers capable of 12.5 Gbps and 6 x72 800-MHz DDR3 interfaces
- Devices with 28-Gbps transceivers

■ Integration

- Embedded HardCopy Blocks supporting PCI Express Gen3 and 40G/100G Ethernet
- High-performance, high-precision DSP
- Enhanced logic fabric with 1,100K LEs, 50 Mb RAM, and 3,510 18x18 multipliers

■ Flexibility

- Fine-grain and easy-to-use partial reconfiguration
- Configuration via PCI Express

■ 50% higher system performance and 30% lower total power



Stratix V Family Plan

	Device	Interconnect			Hard IP		Core Fabric			
		Transceivers (12.5G, 28G)	GPIO	72-bit DDR3	x8 PCIe Gen3	40G/100G Ethernet	LEs	Memory M20K (Mb / #Blocks)	18x18 Multi	fPLLs
Stratix V GT FPGA	5SGTB5	32, 4	597	4	1	Yes	425K	45 / 2304	512	24
	5SGTB7	32, 4	597	4	1	Yes	622K	50 / 2560	512	24
Stratix V GX FPGA	5SGXA3	36, 0	624	4	1 or 2	Yes	200K	20 / 1034	376	24
	5SGXA4	36, 0	624	4	1 or 2	Yes	300K	26 / 1316	376	24
	5SGXA5	48, 0	840	6	1 or 4	Yes	425K	45 / 2304	512	28
	5SGXA7	48, 0	840	6	1 or 4	Yes	622K	50 / 2560	512	28
	5SGXB5	66, 0	648	4	1 or 4	Yes	404K	36 / 1836	612	24
	5SGXB6	66, 0	648	4	1 or 4	Yes	534K	39 / 1989	612	24
Stratix V GS FPGA	5SGSB7	27, 0	1032	7	1 or 2	No	563K	32 / 1620	3,240	22
	5SGSB8	27, 0	1032	7	1 or 2	No	706K	34 / 1755	3,510	22
Stratix V E FPGA	5SEB9	-	900	7	-	No	968K	33 / 1596	1,064	32
	5SEBA	-	900	7	-	No	1087K	43 / 2100	1,100	32

Increased Efficiency and System Performance

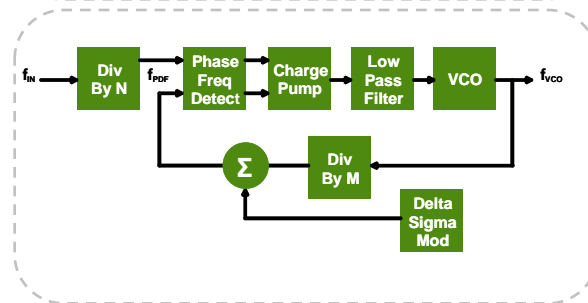
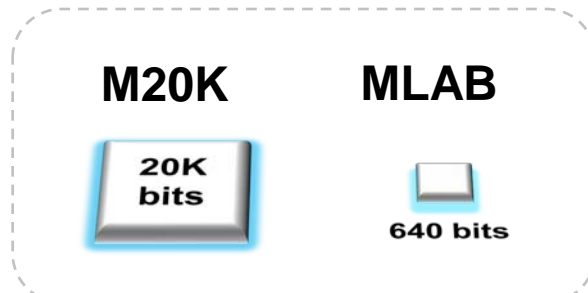
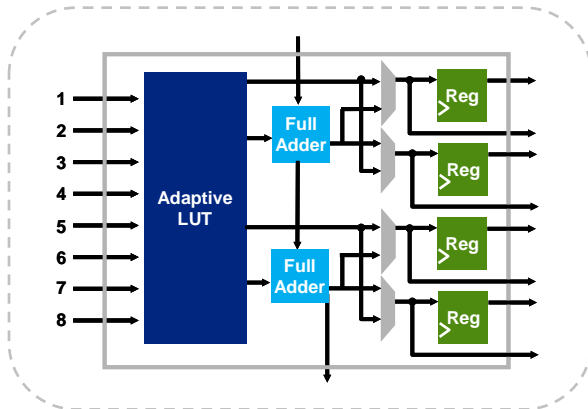

- New ALM architecture
 - Higher logic efficiency and performance
 - 800K additional registers on largest device
 - Ideal for heavily pipelined and register-rich designs
- New M20K block and MLAB
 - Improved area efficiency and higher system performance
 - Up to 53 Mbits embedded RAM
- New fPLLs - high resolution clock synthesis
 - Replaces board-level clock frequency sources (VCXOs) and reduces clock pins
- Enhanced routing
 - Easier timing closure and higher utilization

Power Techniques

Power Reduction Methods	Lower static power	Lower dynamic power
28-nm process changes	✓	✓
Low power transceivers (200mW @ 28 Gbps)	✓	✓
Programmable Power / Adaptive Body Bias	✓	
Lower core voltage (0.85V)	✓	✓
Extensive hardening of IP, Embedded HardCopy Blocks	✓	✓
Hard power down of functional blocks	✓	✓
Clock gating		✓
Customized extra-low leakage devices	✓	
Partial Reconfiguration	✓	✓
DDR3 and dynamic on-chip termination	✓	✓

New Embedded HardCopy Block

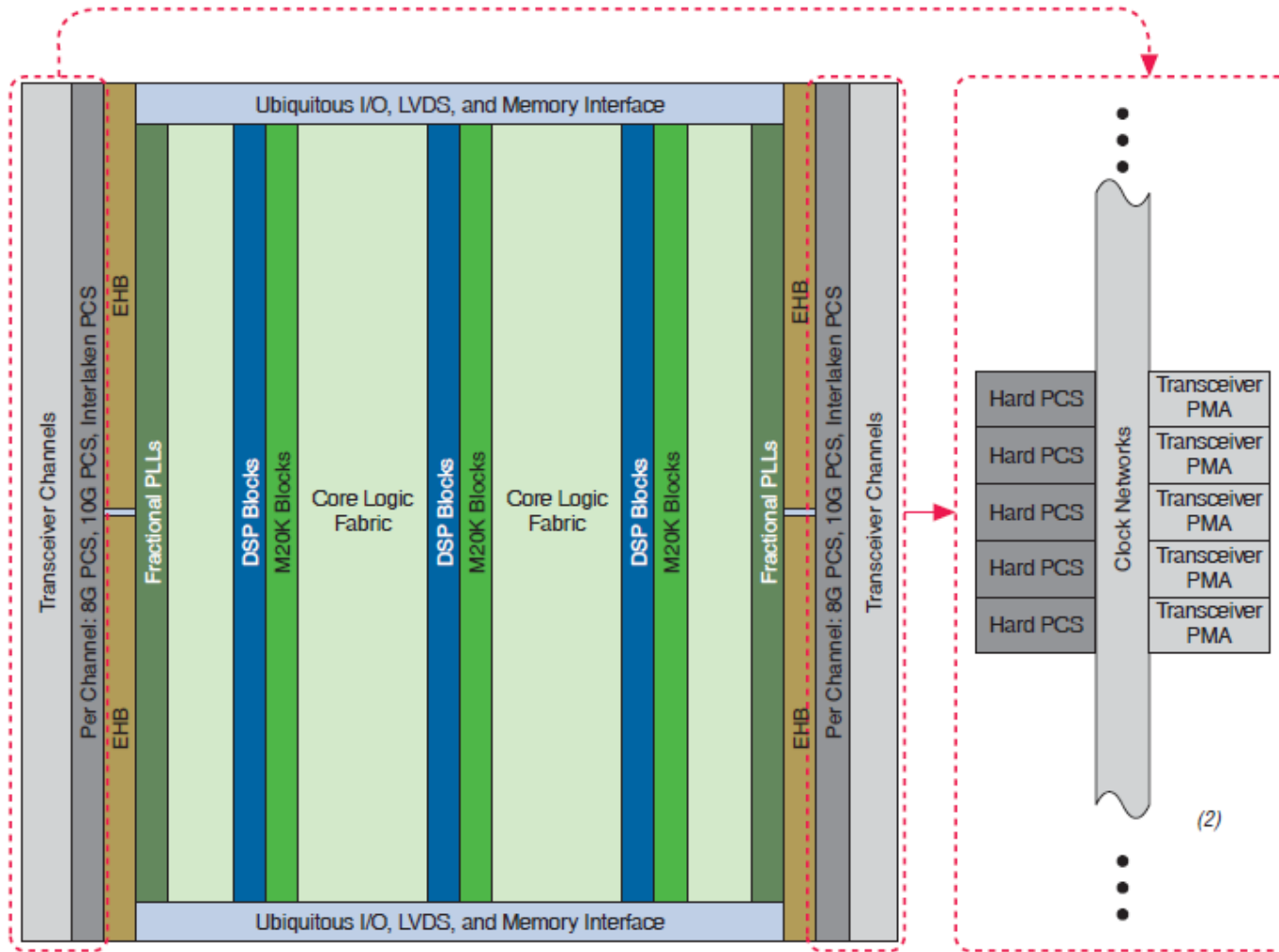

Flexible Transceiver Architecture

- Scalability and flexibility through a continuous bank of transceivers
- Complete PMA+PCS per channel
- Flexible clocking options with abundant transmit clock sources enabling up to 44 independent data rates

Transmit Clock Source	Number	Data Range (Gbps)
28G LC PLL	4	20 - 28
12G LC PLL	22	3.25 - 12.5
CMU PLL	22	0.6 – 12.5
Core PLL (fPLL)	22	0.6 – 3.75

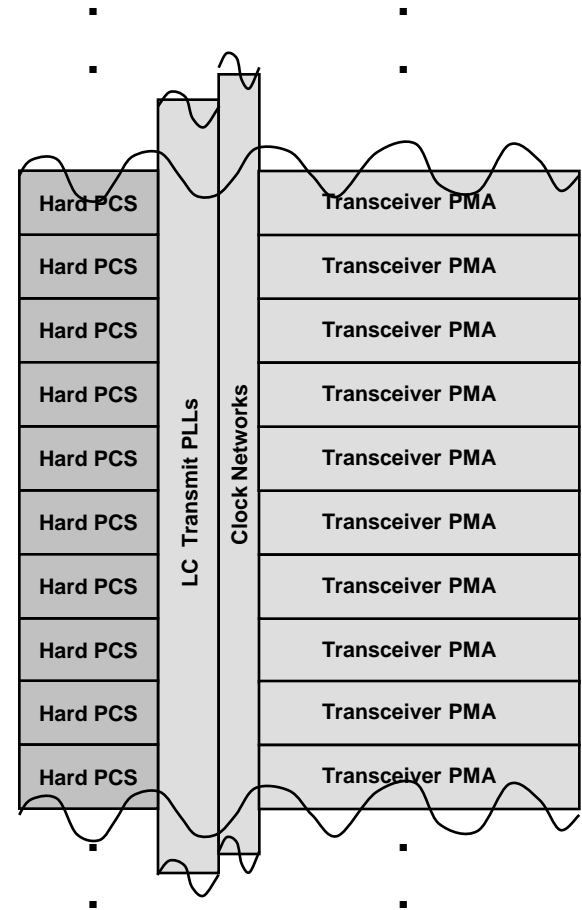

Stratix V Integrated Hard IP

Embedded HardCopy Block Hard IP	
x8 PCIe Gen3	PCS, PHY/MAC, data link, transaction layer
40GE/100GE	MLD/PCS – gearbox, block sync, alignment marker, reorder virtual channel, async buffer/deskew, block striper/destriper, scrambler/descrambler

Transceiver PCS Hard IP	
Interlaken	Gearbox, block sync, 64b/67b, frame sync, scrambler/descrambler, CRC-32, async buffer/deskew
10GE (10GBASE-R)	Gearbox, block sync, scrambler/descrambler, 64b/66b, rate matcher
SRIO 2.0	Word aligner, lane sync state machine, deskew, rate matcher
CPRI/OBSAI	Word aligner, bit slip (deterministic latency)

External Memory Interface

- New UniPHY enables half the latency of ALTMEMPHY
- High system reliability
 - Duty cycle correction
 - Calibration algorithms
 - VT compensated deskew delays
 - PVT tracking mechanisms
- Sharing of PLLs and DLLs across multiple interfaces
- Hard I/O FIFOs and read/write paths
- Ease of use
 - UniPHY available as cleartext
 - Nios processor-based calibration sequencer for easier debug and customization
 - Easy-to-use application of timing and pin constraints
 - Improved documentation

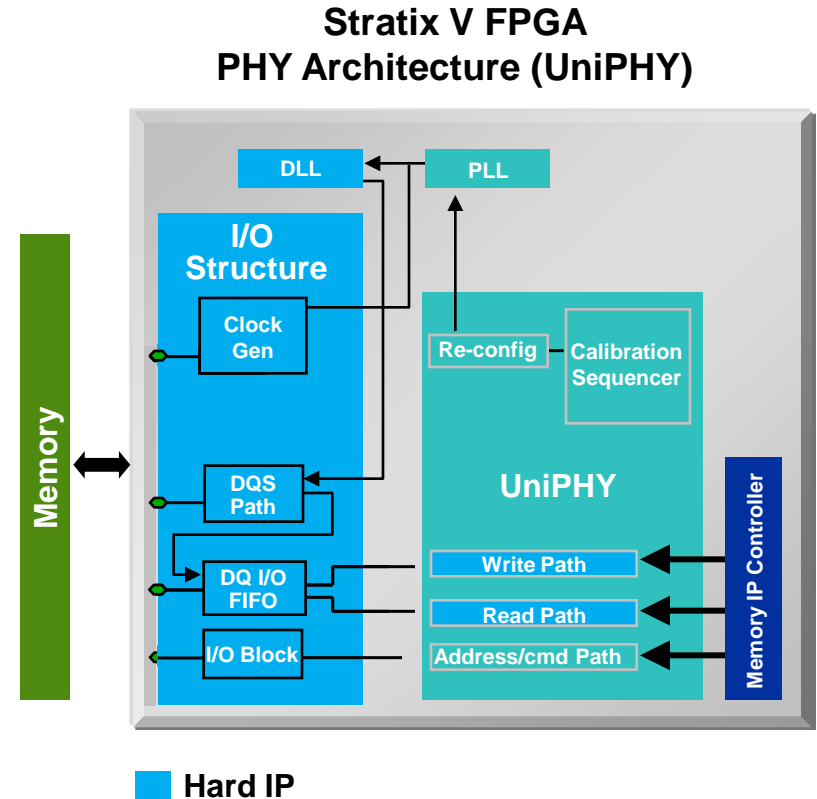

Stratix V Transceivers

August 2010

High-Bandwidth Transceivers

- 28-Gbps transceivers
 - 20 Gbps to 28 Gbps
 - Up to 4 full-duplex transceiver channels
 - CEI-28G compliant
- 12.5-Gbps transceivers
 - 150 Mbps to 12.5 Gbps
 - Up to 66 full-duplex transceiver channels
 - SFP+ and 10GBASE-KR compliant
- Independent transceivers
 - Change transceiver settings (PMA or PCS) without interrupting other transceiver channels
- Overcome channel losses
 - Ultra-low transmit jitter (LC PLL) and excellent jitter tolerance (analog CDR)
 - Four signal-conditioning techniques to compensate for losses

Backplanes and Optical Modules

- Drive 40” backplanes at 12.5 Gbps
 - 10GBASE-KR compliant (IEEE 802.3AP Clause 72)
- Interface to optical modules directly
 - Built in electronic dispersion compensation (EDC)
 - XFP, SFP+, QSFP, and CFP compliance
- Signal conditioning
 - Pre-emphasis and de-emphasis
 - Four-stage continuous time linear equalizer (CTLE)
 - 5-tap decision feedback equalizer (DFE)
 - Adaptive dispersion compensation engine (ADCE)
- On-die instrumentation
 - Monitor eye margin within the receiver
 - Evaluate effectiveness of signal-conditioning techniques

Stratix V FPGA EyeQ Eye Viewer

- Complete vertical and horizontal reconstruction of eye opening
- Uninterrupted data path for live debug capability
- Serial and parallel data verification for live in-system eye reconstruction
- Known pattern not necessary
- Evaluate effectiveness of signal-conditioning techniques
 - Select optimal pre-emphasis, CTLE, and DFE settings for largest eye opening

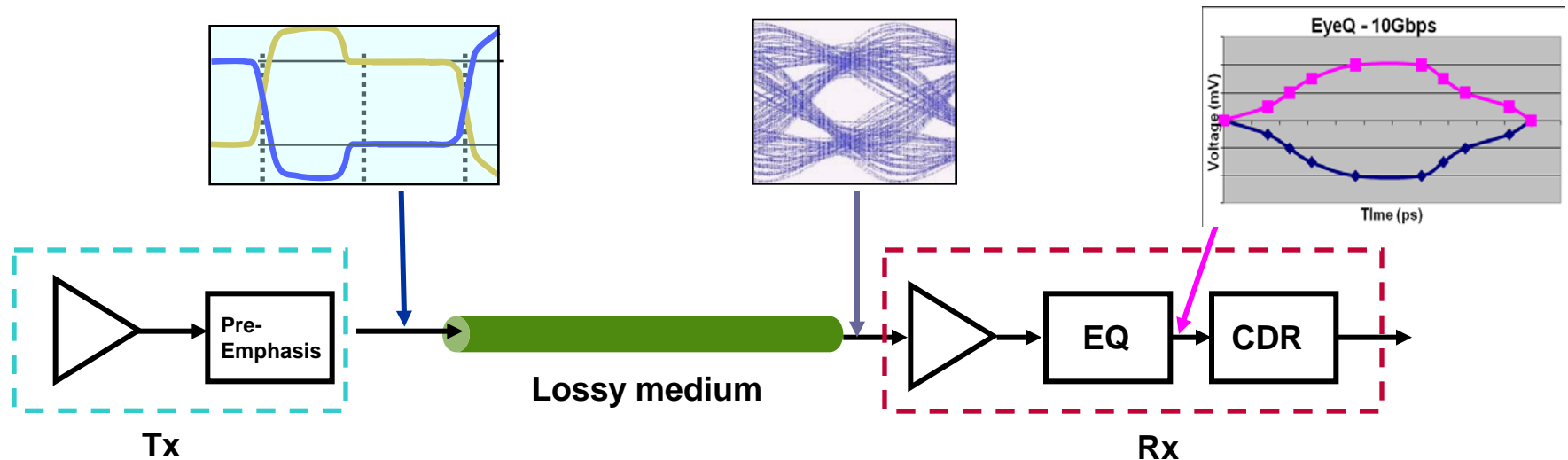

EyeQ Circuit

EQ: Equalizer
 PD: Phase Detector
 CP: Charge Pump
 VCO: Voltage Controlled Oscillator
 PI: Phase Interpolator

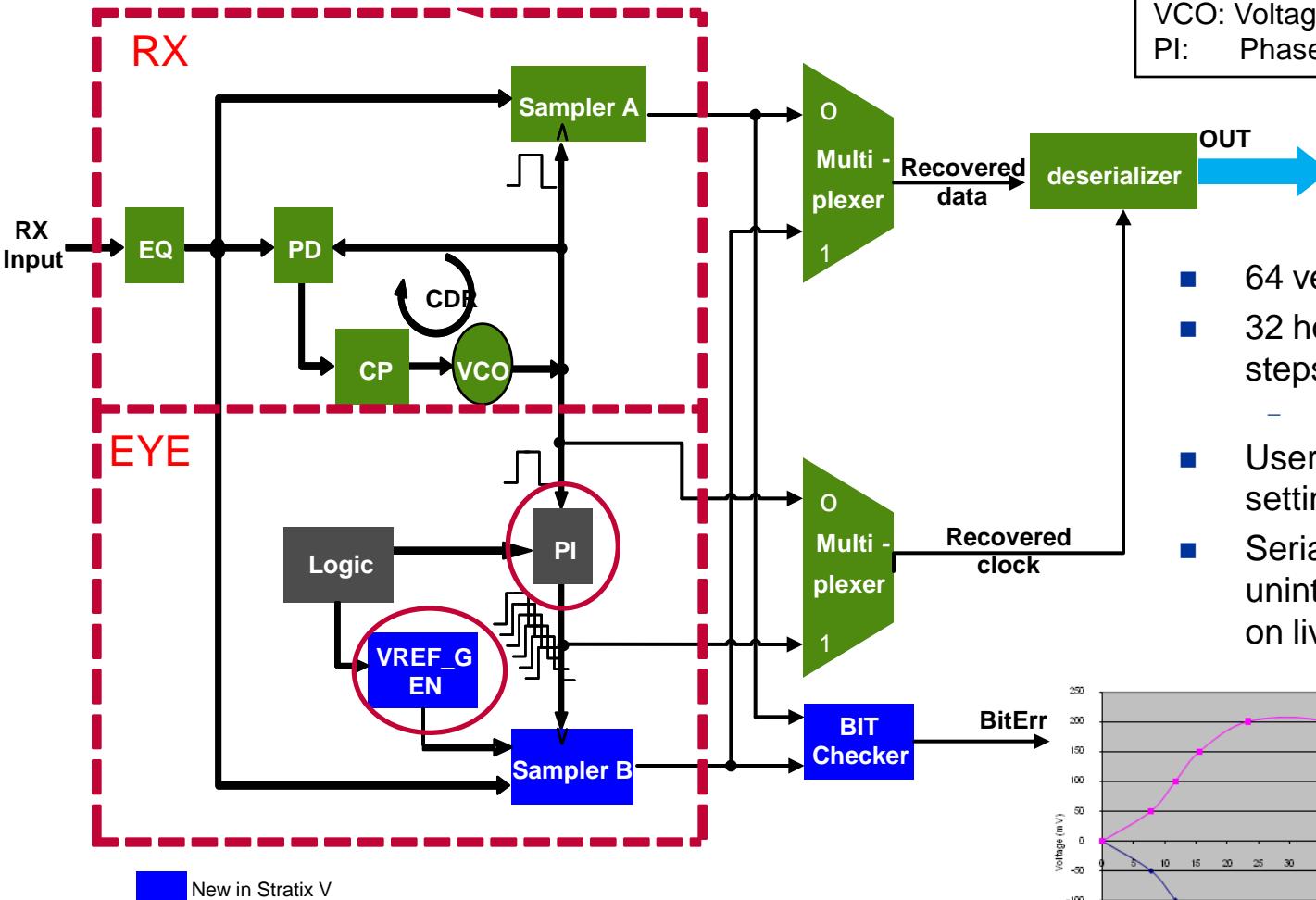

- 64 vertical threshold levels
- 32 horizontal phase-interpolator steps
 - 3ps / steps (@ 10Gbps)
- User selectable threshold / PI setting
- Serial bit checker allows for uninterrupted eye reconstruction on live traffic

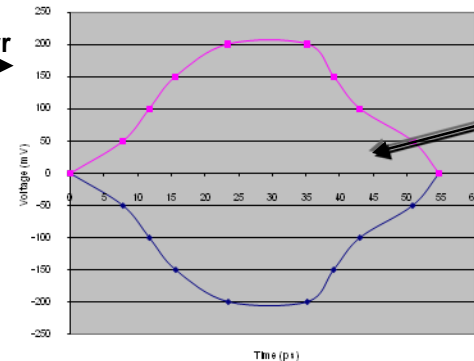

High Bandwidth at Low Power

- Lower power - 50% power reduction at 11.3 Gbps
- A fraction of the power (< 10%) compared to external transceivers
 - 28 Gbps ~200 mW per channel
 - 12.5 Gbps ~170 mW per channel
 - 6.5 Gbps ~ 80 mW per channel

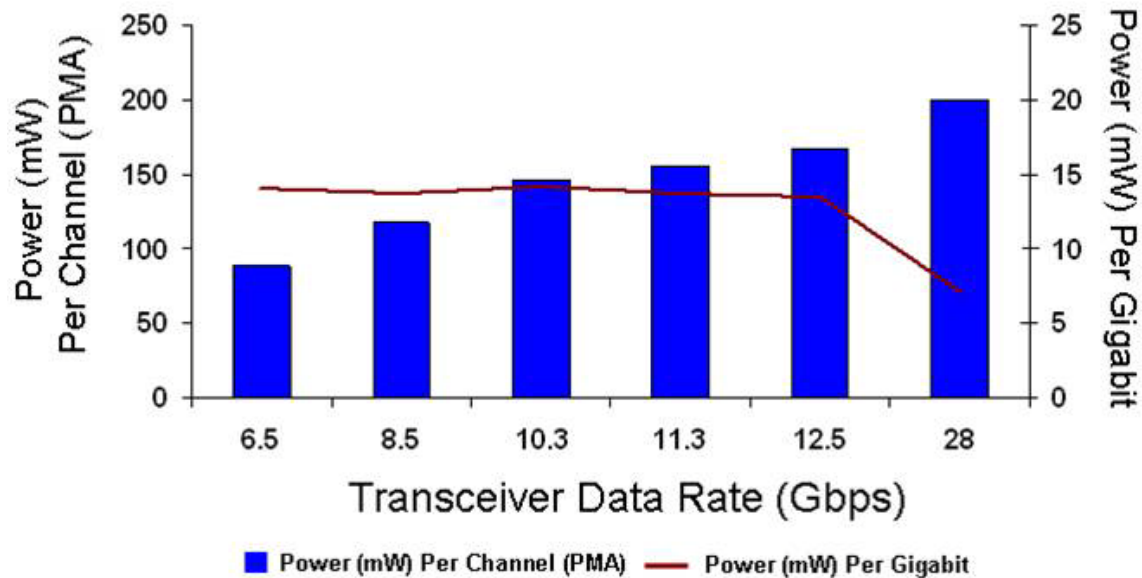

Transceiver Power at 28 Gbps/28 nm

28Gbps PMA Power (mW)	Post-LY	Post-LY
	Base features	+Optional features
RX-CTLE	25	25
RX-DFE (est)		35
CDR	98	98
Deserializer	27.8	27.8
TX driver	30	30
TX-FFE (6 dB)		11
Serializer	20	20
TOTAL	201	247
FOM (mW/Gbps)	7.18	8.82

- Low-power design enables the 28nm transceiver achieves ≤ 8.82 mw/Gbps (pJ/bit) power FOM at 28 Gbps

World's First 28nm Transceiver at 28 Gbps

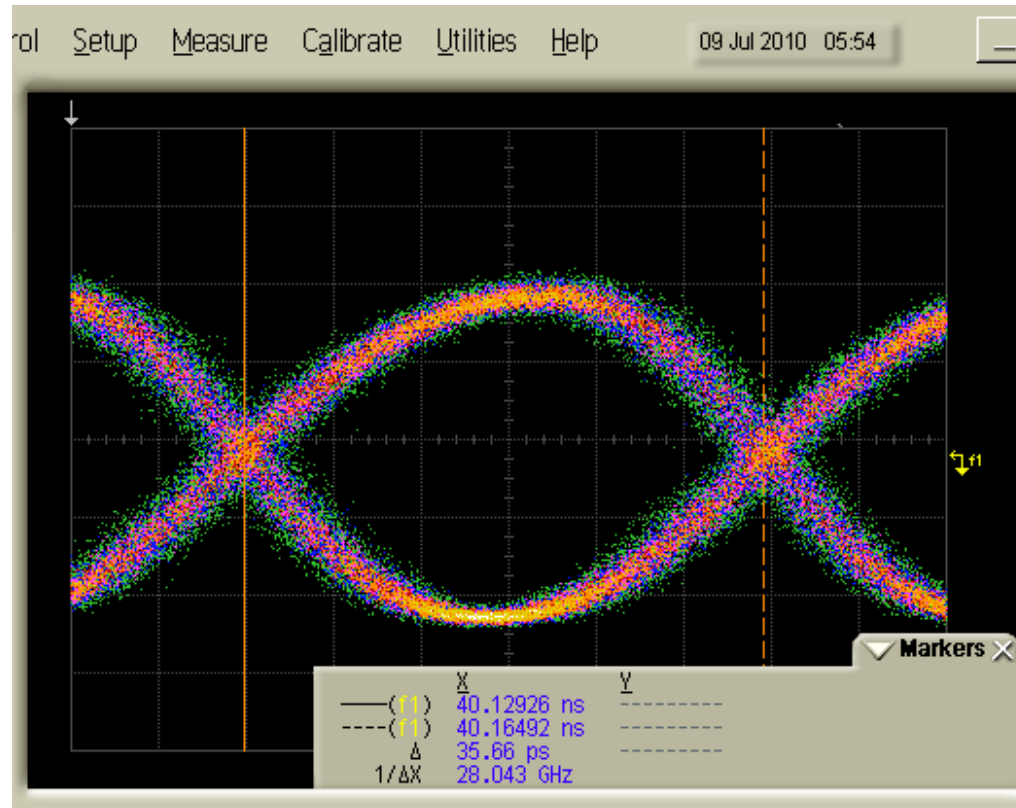

- Tx eye diagram measured from a 28nm chip

28Gbps Transceiver Physical View

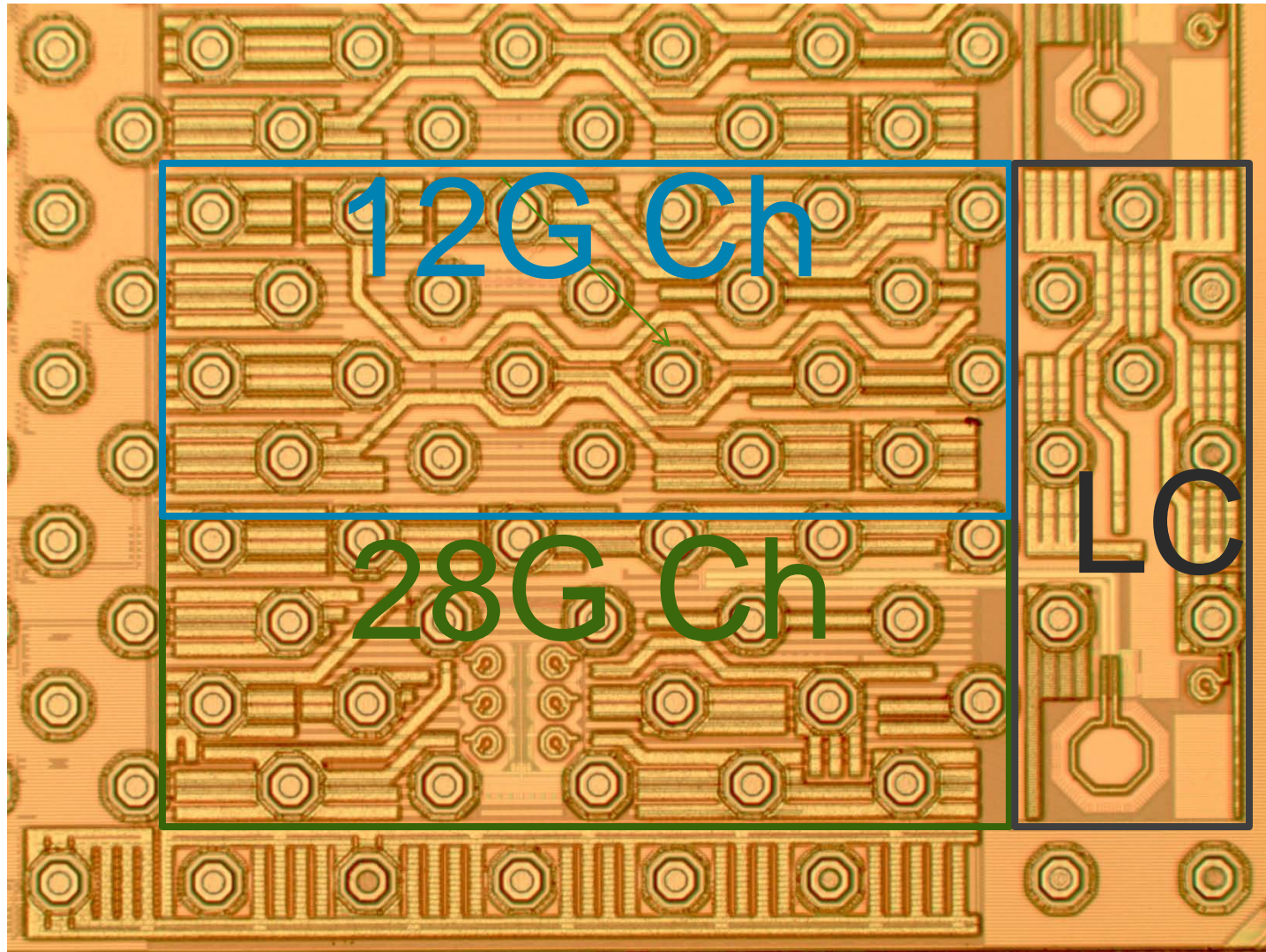

RF Die-Package Design

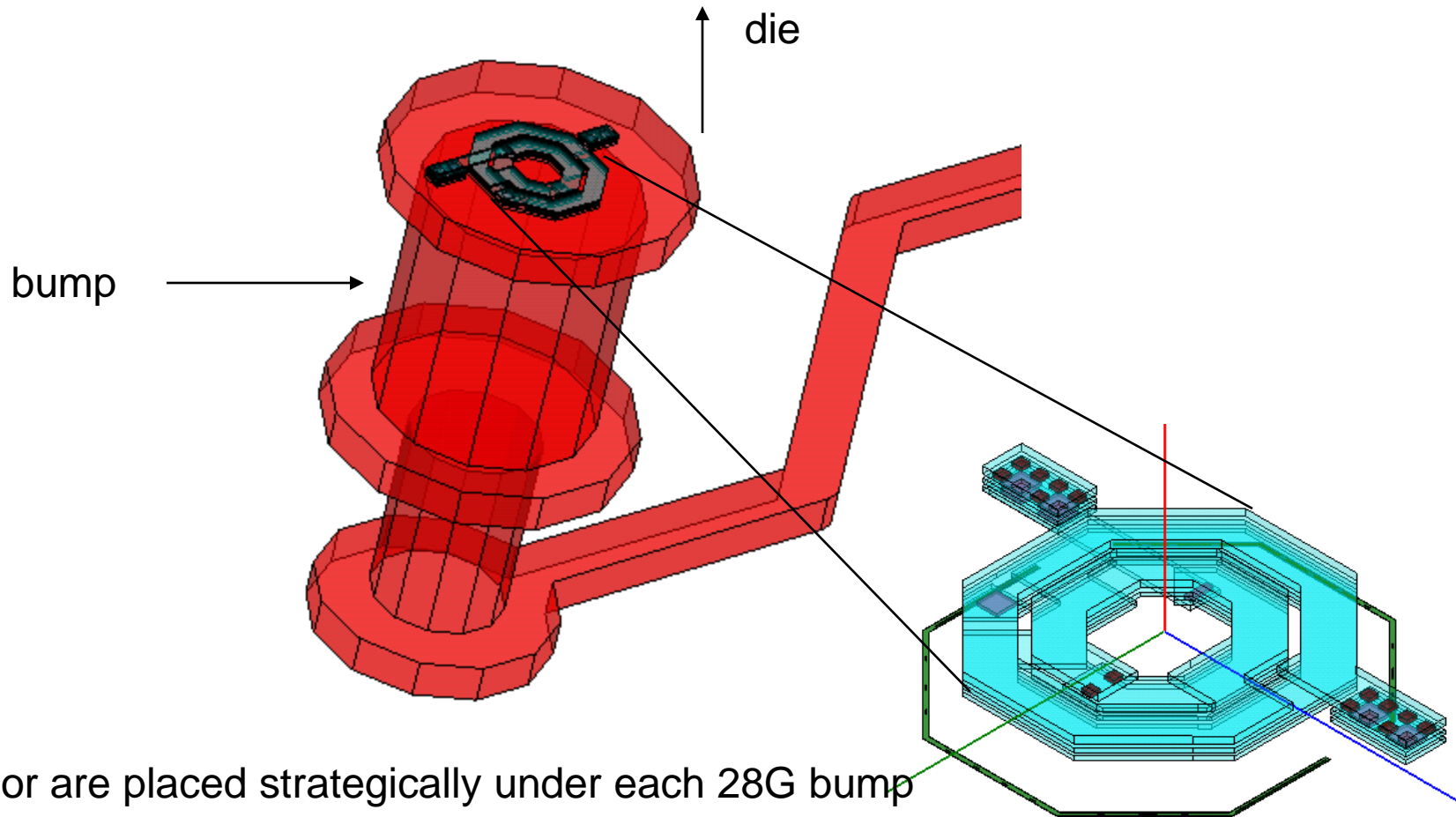

Inductor are placed strategically under each 28G bump to tune out parasitic loading

Signal Conditioning Working

- Support up to 12.5Gbps data rate
 - For c2c, c2m and backplane

- RX Path (CTLE):

- 4 EQ stages: up to 20dB programmable AC gain
- Peaking is independently controlled to meet 6G and 12G BPs
- Programmable DC gain of 3dB/6dB/9dB/12dB with 3dB/stage

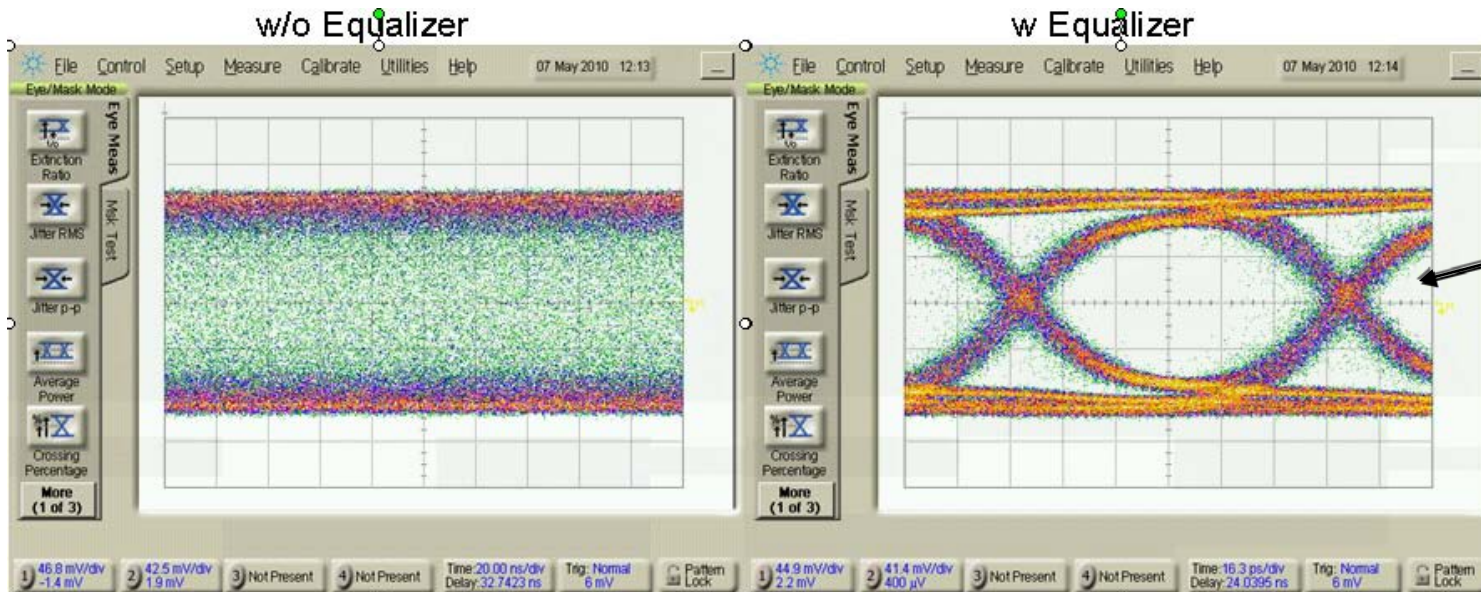
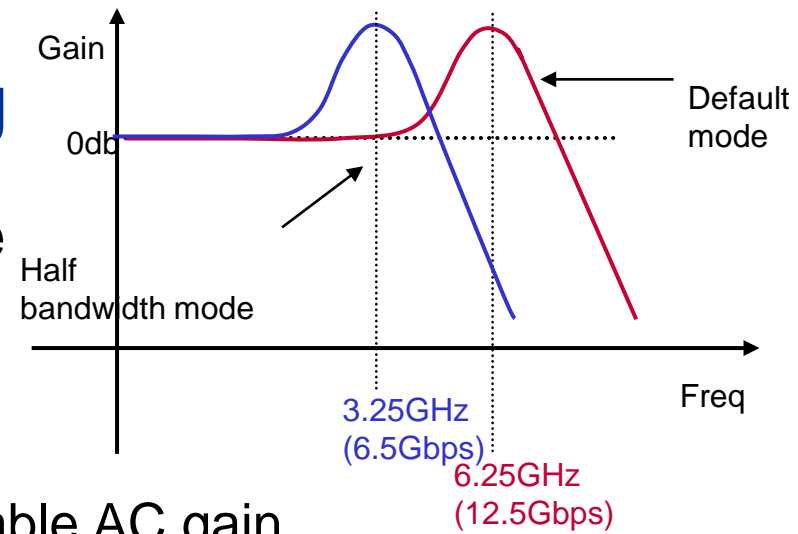

28nm
Measured
Results
(actual)

28-nm Transceiver Demonstration Board

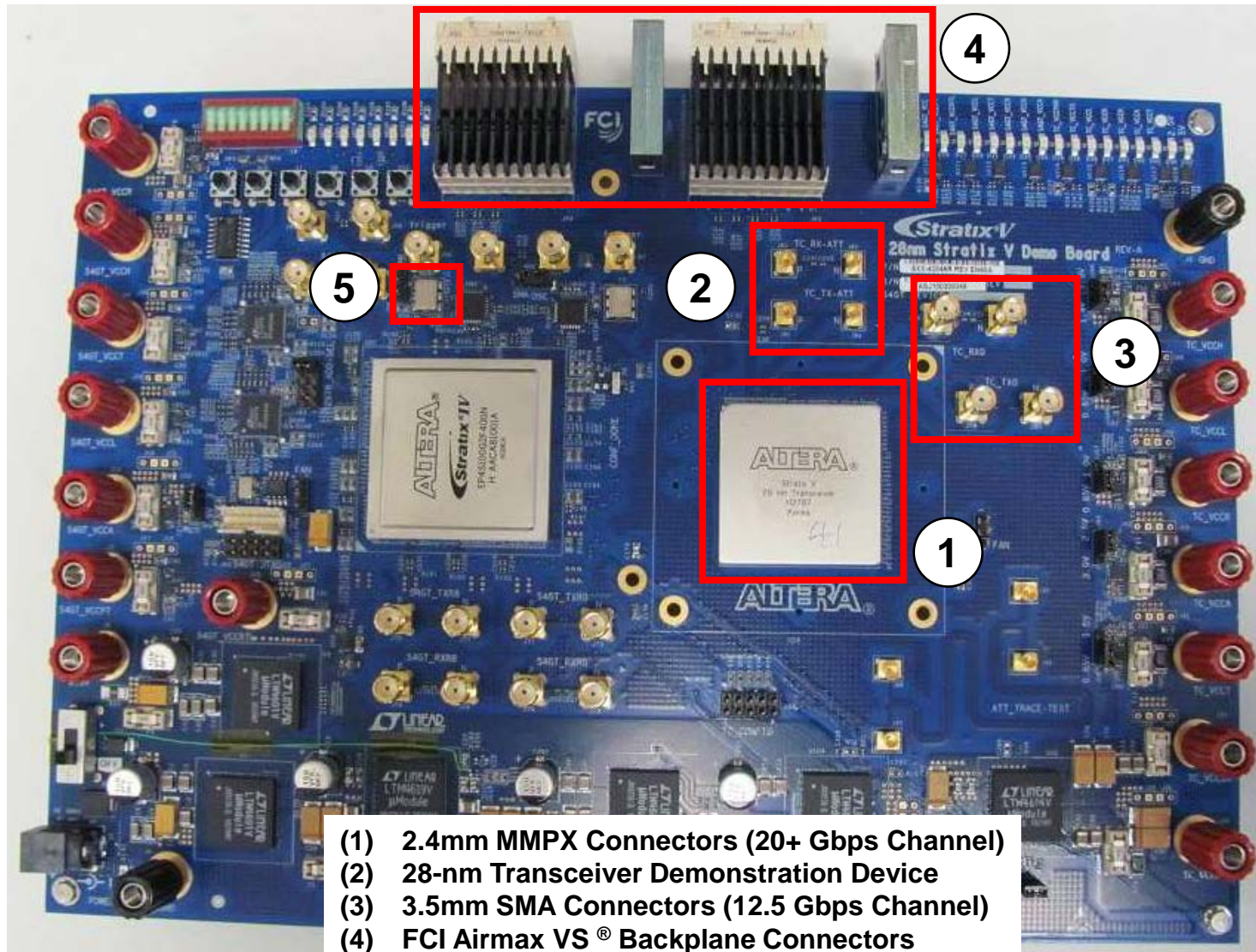

- (1) 2.4mm MMPX Connectors (20+ Gbps Channel)
- (2) 28-nm Transceiver Demonstration Device
- (3) 3.5mm SMA Connectors (12.5 Gbps Channel)
- (4) FCI Airmax VS[®] Backplane Connectors
- (5) Programmable Clock Oscillator

© 2010 Altera Corporation—Hot Chips 22 2010

ALTERA, ARRIA, CYCLONE, HARDCOPY, MAX, MEGACORE, NIOS, QUARTUS & STRATIX are Reg. U.S. Pat. & Tm. Off. and Altera marks in and outside the U.S.

ALTERA