

# Silicon Photonics: Optical Connectivity at 25 Gbps and Beyond.

Presenter: Brian Welch  
Company: Luxtera

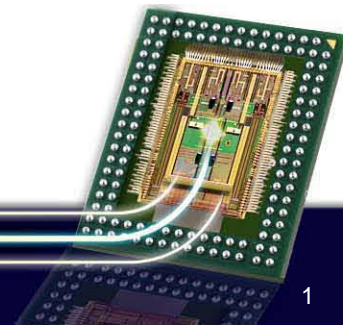

# Outline

- **Motivation**
  - Limitations of conventional solutions
  - CMOS photonics advantages
- **CMOS photonics technology overview**
- **Light Sources for CMOS Photonics**
- **CMOS Photonics Transmitter**
- **CMOS Photonics Receiver**
- **Optical Transmission Channel**
- **Future technology direction**
- **Conclusion**

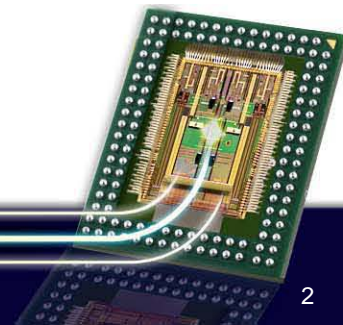

# Motivation

- **Interconnect quickly moving beyond 10Gbps per lane**
  - 16G Fibre Channel : 1x14 Gbps
  - FDR Infiniband : 4x14 Gbps
  - EDR Infiniband : 4x25 Gbps
  - 100G Ethernet : 10x10Gbps → 4x25 Gbps
  - 32G Fibre Channel : 1x28 Gbps
- **Reach of copper decreases rapidly with faster data rates**
  - Driving the need for lower cost optical interconnect
- **More system ports require optical interconnects**
  - Higher proportion of system cost and power going to interconnect
  - Interconnect limitations can impair interconnect fabric roadmap
    - Move to parallel vs. serial solutions

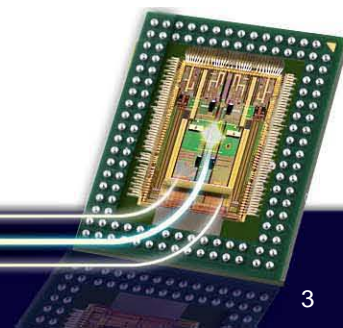

# VCSEL Challenges with Scaling Beyond 14G

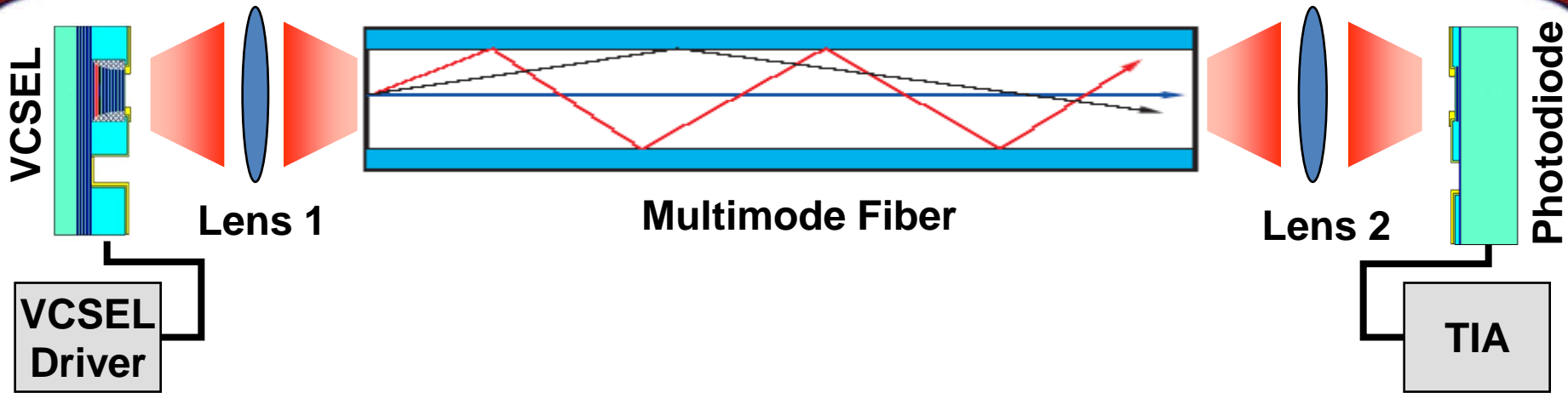

## VCSEL Transmitter

- VCSELs need to be driven with high bias currents in order to operate at high speeds. Reduced diameter also required.
- Results in high current density and hence reduced VCSEL reliability and manufacturability.

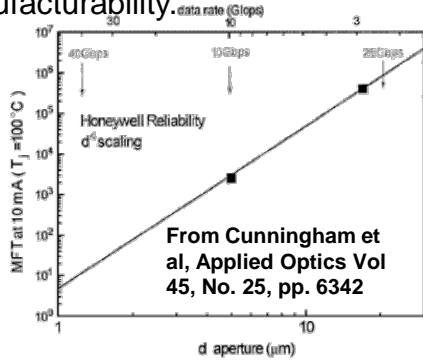
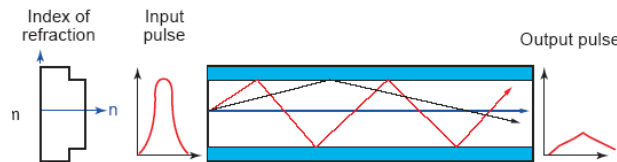

Fig. 4. Scaling of the MTTF versus aperture for Honeywell VCSELs.

## Multimode Fiber Medium

- Modal and chromatic dispersion limit bandwidth.
- OM3 fiber has a bandwidth length product of  $\sim 2000 \text{ MHz} \cdot \text{km}$  under optimum coupling conditions.
- Chromatic dispersion is dealt with by stringent specs on laser spectral line width (lower yield).



## Multimode Receiver

- Multimode fiber receivers require large area photo-detectors (60-70 micron diameter), capacitance is in the order of 240 fF.
- Receiver bandwidth determined by RC time constant of PD/TIA. Reducing R is a possibility but that reduces the gain (receiver sensitivity).

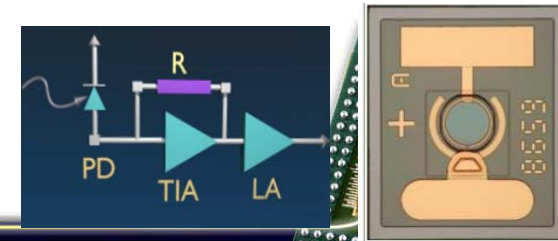

# CMOS Photonics Technology Summary

## Basic Technology:

- Integration of photonic and electronic functions on one die (low cost)
- Manufactured using standard tools in a mainstream CMOS fab

## Lux-G process:

- Based on Freescale Semiconductor 130 nm SOI CMOS node
- Reliability qualified per JEDEC 001
- Currently in full manufacturing mode (maturity level 3)

## Integrated functions on CMOS die:

- Electronic circuits
- Passive and active waveguide devices
- Coupling structures
- Photo-detectors

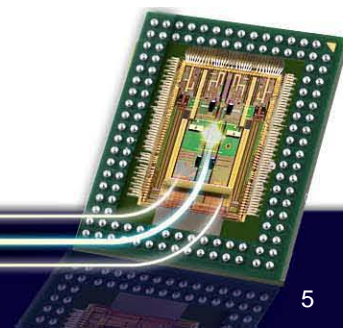
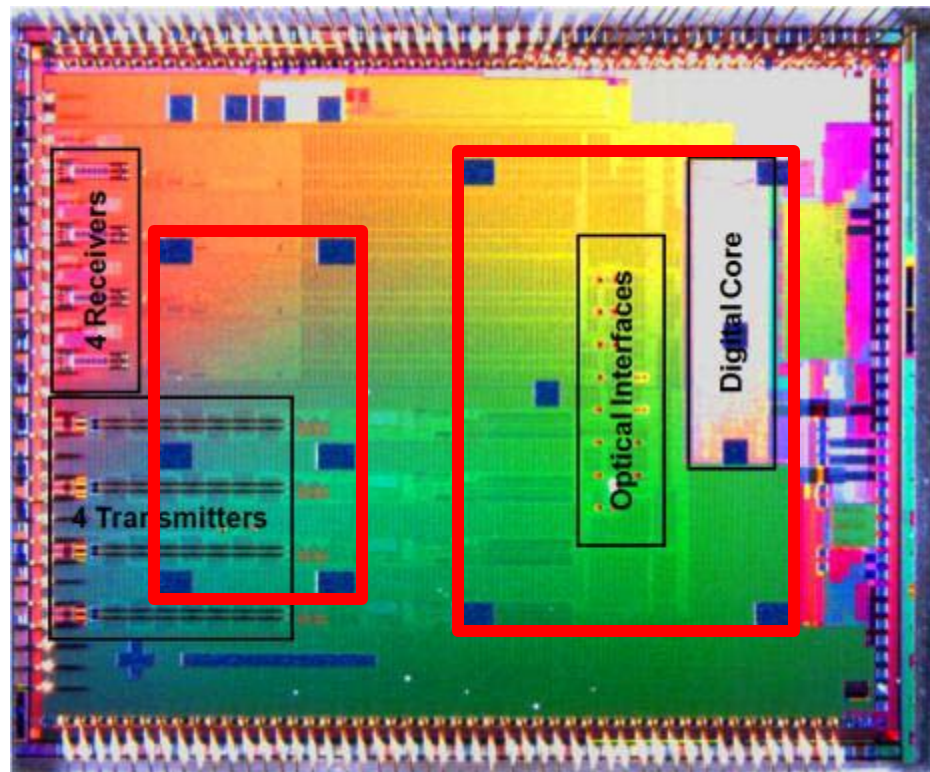

# CMOS Photonics Ecosystem

Automated design infrastructure:

- extensive photonics device library
- full electronic-photonic DRC & LVS
- circuit & system simulation

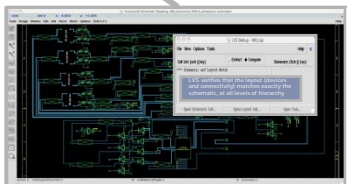

Photonic structures on custom SOI wafer by standard CMOS processes: waveguides, couplers

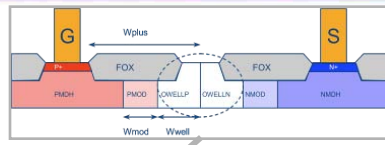
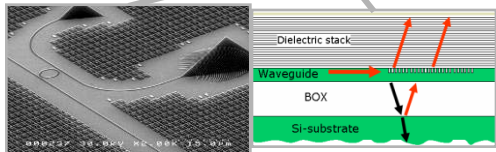

Doping for EO structures:

- high speed modulators
- phase shifters
- VOA

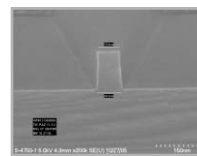
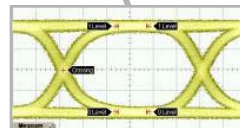

Standard CMOS gate process

Selective growth of Germanium islands for photo-detectors

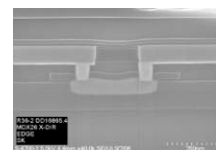

Standard CMOS metal interconnects & vias

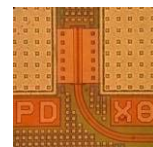

Standard CMOS Passivation & End Metal

Fully automated wafer level photonic and electrical probing

Die Singulation



Automated Laser Attach



Packaging & Automated Fiber array Attach

Automated Test

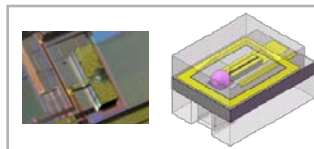
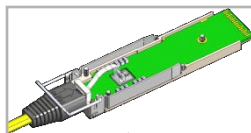
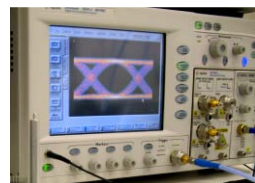

Complete Ecosystem from chip design to finished product

PRODUCT



# Light Source for CMOS Photonics

Light source operates CW

Single laser for multiple channels

- Cost reduction
- Power reduction
- Improved reliability
- Presently up to 150 Gbps of throughput per laser
  - Moving to 300+ Gbps of throughput per laser

Silicon photonics solutions can be implemented from 1260nm to 1570 nm.

MQW DFB laser diodes

- Current wavelength 1490 nm
- Manufactured in volume by several vendors (FTTH)
- DFB lasers have very good reliability track record ( very low random and wear-out failure rate, both < 1 FIT)

Laser diode packaged in hermetic silicon housing

- High reliability
- Waferscale Manufacturing

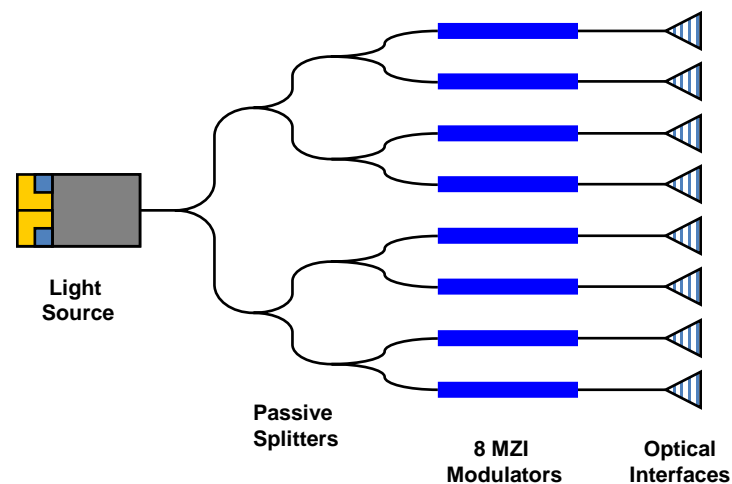
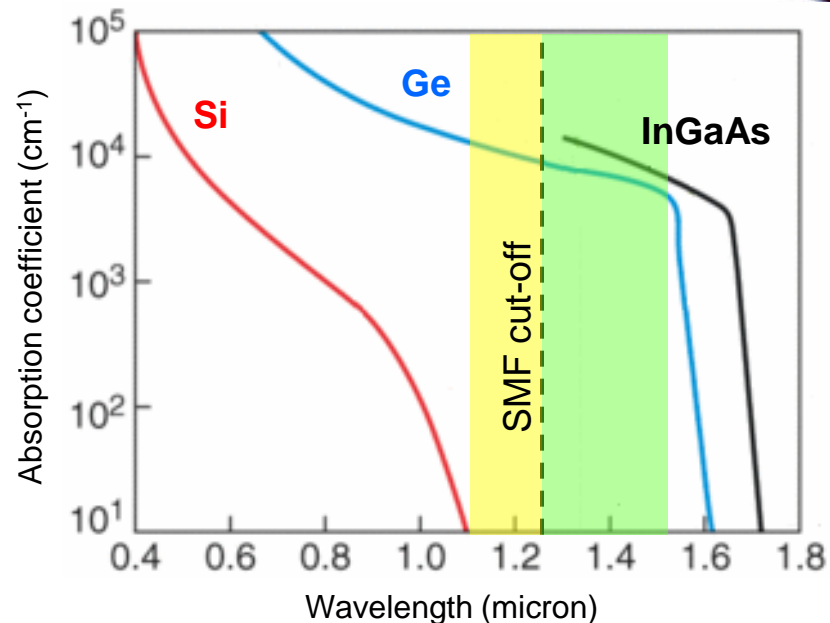

# Transmitter - Photonics

## Basic high-speed phase modulator

- Based on carrier depletion
- Reverse-biased lateral pn junction provides high-speed phase modulation
- Theoretical speed limited by:
  - Relaxation time ( $= \varepsilon \cdot \sigma = 12.3 \cdot 8.6 \cdot 10^{-14}$  F/cm $\cdot$ 1  $\Omega$ .cm = 1 ps)
  - **Bandwidth = 160 GHz**
- Voltage swing: 0 to 2 V reverse bias

## Distributed Mach Zender Interferometer enables better Opto-Electric phase matching

- Enables waveform shaping to center peak OMA at 0.5 UI
- Enables transmitter power reduction

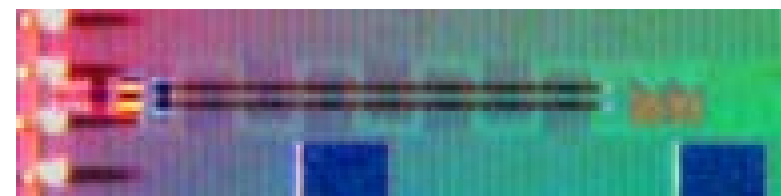
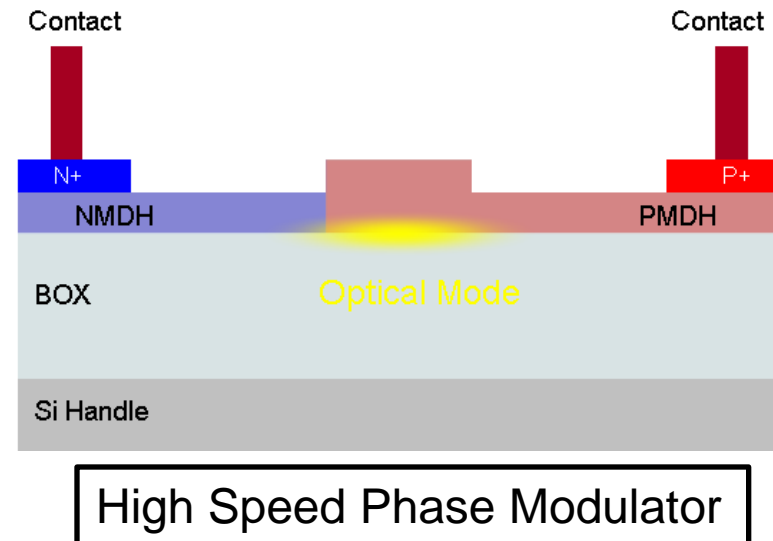

Distributed MZI

# Transmitter - Electronics

## Stacked domain design

- Enables high speed, low voltage CMOS to be used.
- Discrete solutions require high voltage drive capabilities (SiGe).

## Distributed electrical driver

- Minimizes parasitics between electronics and optics.
- Discrete solutions require wire bond or flip-chip interconnects.

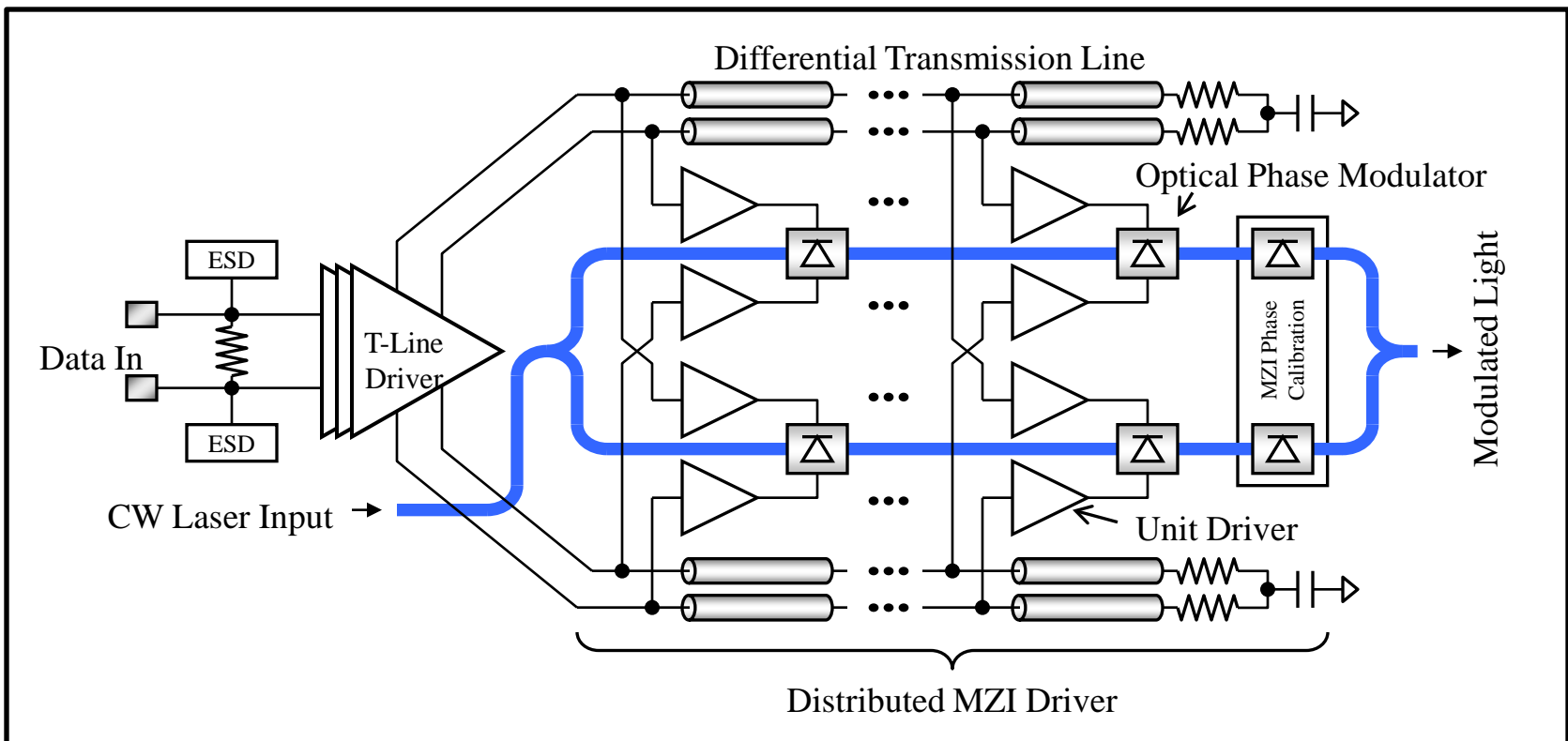

# Transmitter – Experimental Results

## Tested 2 mm long MZI

- Existing, discrete test structures not optimized for high speed performance

## Straightforward optimization for 4 x 25 Gbps and higher

- MZI Deterministic jitter generation < 4 ps
- Implementation within distributed MZI would reduce yield DJ < 2ps

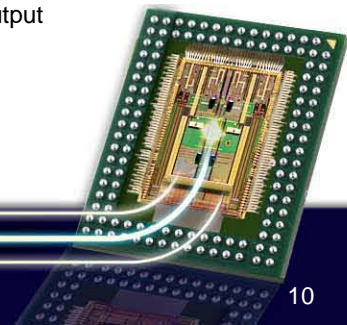
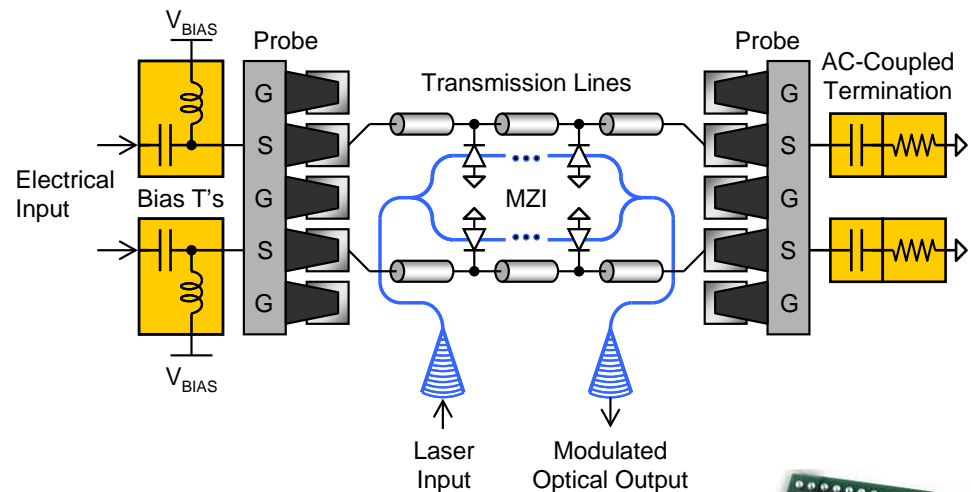
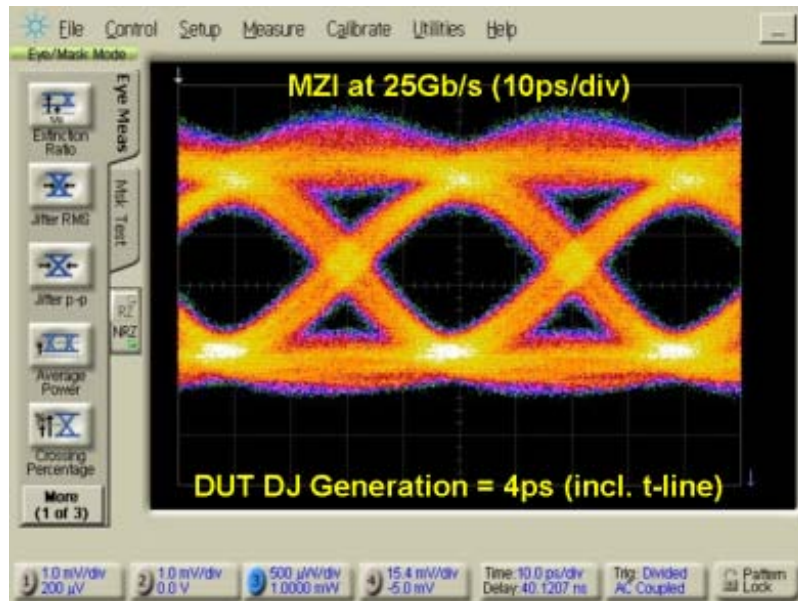

# Receiver - Photonics

## Conventional surface illuminated photodiodes, design trade-off :

- Increase bandwidth by reducing transit-time (reduce thickness of depletion region)
- Increase bandwidth by reducing capacitance (reduce surface area)

## Waveguide photo-detectors, design trade-off broken:

- Absorption and collection occur along perpendicular directions
- Speed and responsivity can be independently optimized

## Theoretical bandwidth of waveguide photo-detector

- Transit-time limited bandwidth, due to very small junction area and hence negligible junction capacitance
- Transit time governing equation (d=depletion thickness, V = applied voltage, u = free carrier mobility)

$$t_t = \frac{d^2}{V\mu}$$

- Existing design, **Bandwidth = 55 GHz**

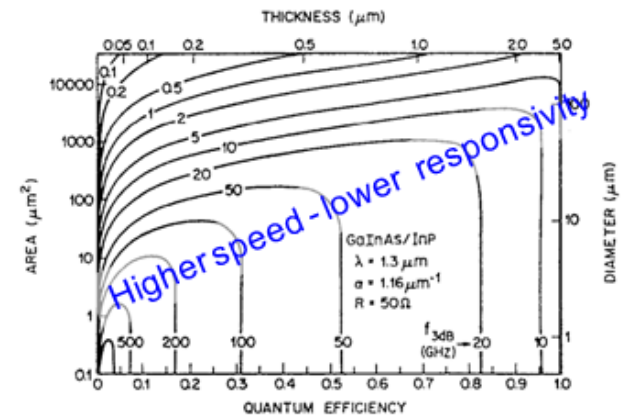
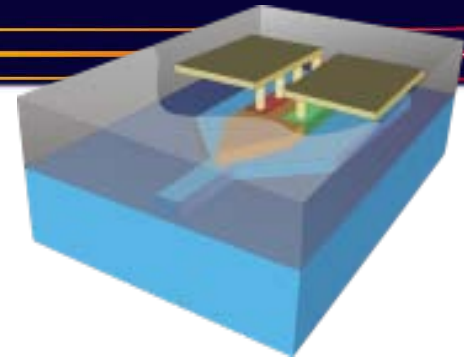

Contours of constant 3-dB bandwidth in the detector-area, depletion-layer-thickness plane. ( $\alpha = 1.16 \mu\text{m}^{-1}$ , (1.3- $\mu\text{m}$  wavelength),  $v_n = 6.5 \times 10^6 \text{ cm/s}$ ,  $v_p = 4.8 \times 10^6 \text{ cm/s}$ ,  $\epsilon = 14.1$ .)

(Bowers1987)

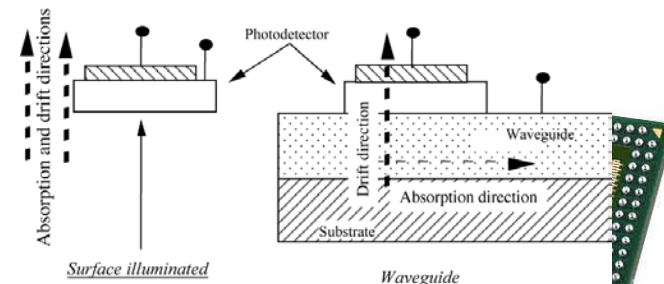

# Receiver - Electronics

**Completely monolithic (integrated photo-detector, regulator, amplifiers, and control/calibration functions)**

- Very low photodiode and parasitic capacitance at PD/TIA node enables very high gain receiver front end → Very high sensitivity
- Integrated solution enables very low jitter compared to discrete solutions

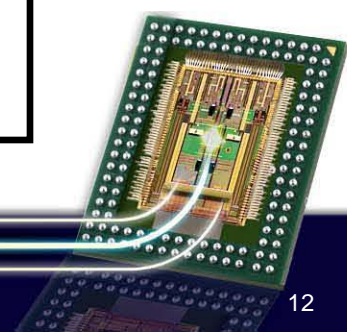
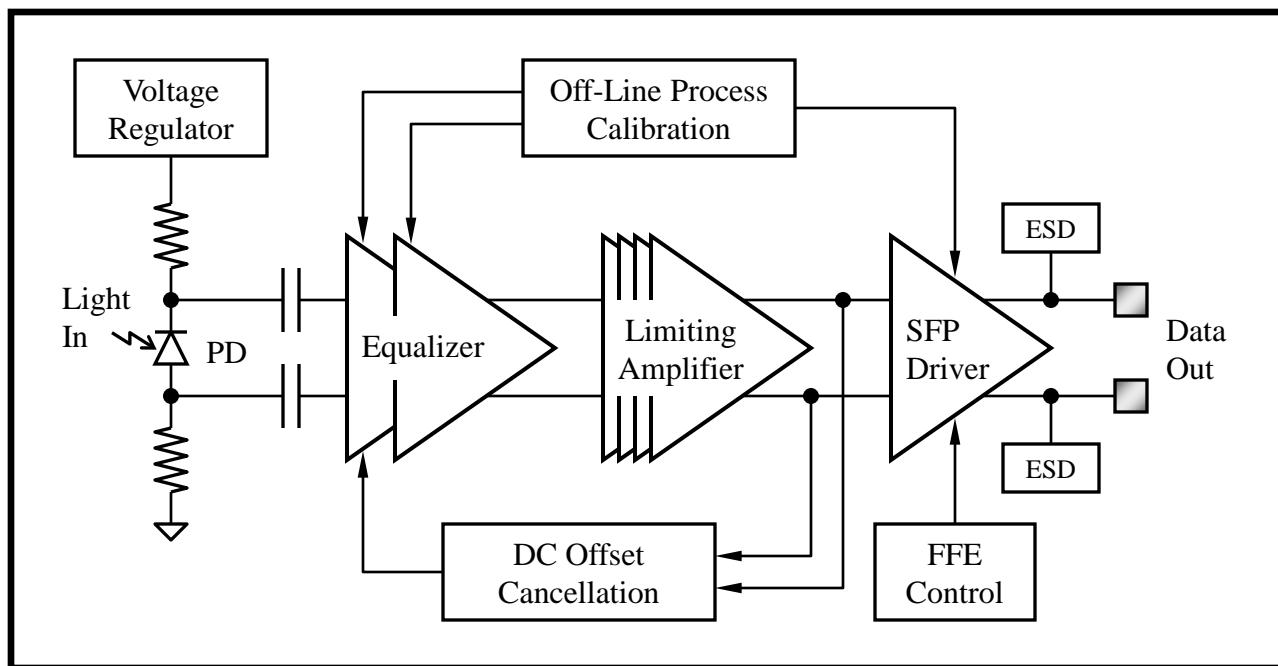

# Receiver – Experimental Results (Preliminary)

## CMOS process technology:

- Selective Ge epitaxy on Si
- Standard CMOS foundry toolset for Ge epitaxy (SiGe stressors, HBT)

## Ge PIN Photo-detector

- Responsivity > 0.85A/W @1490nm
- Capacitance < 15fF @ -1.2V
- Demonstrated operation at 25 Gb/s (without optimization)

## Reliability:

- PIN qualified per Telcordia GR-486-CORE

## System performance:

- Low capacitance allows much higher sensitivity than discrete solutions (~4 dB)

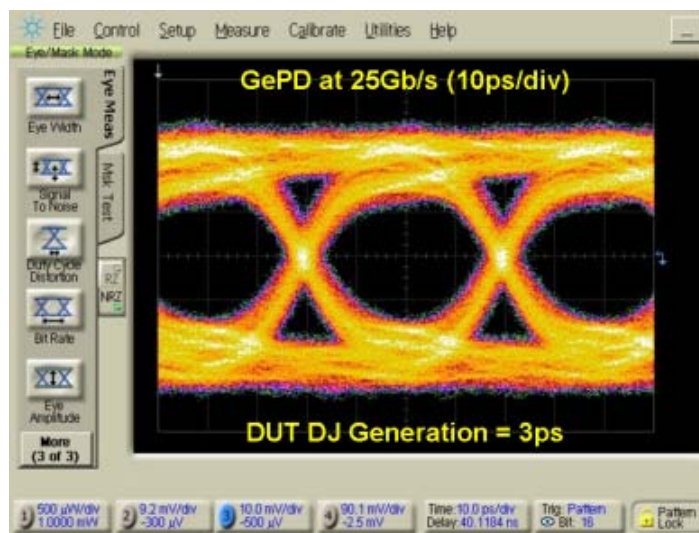
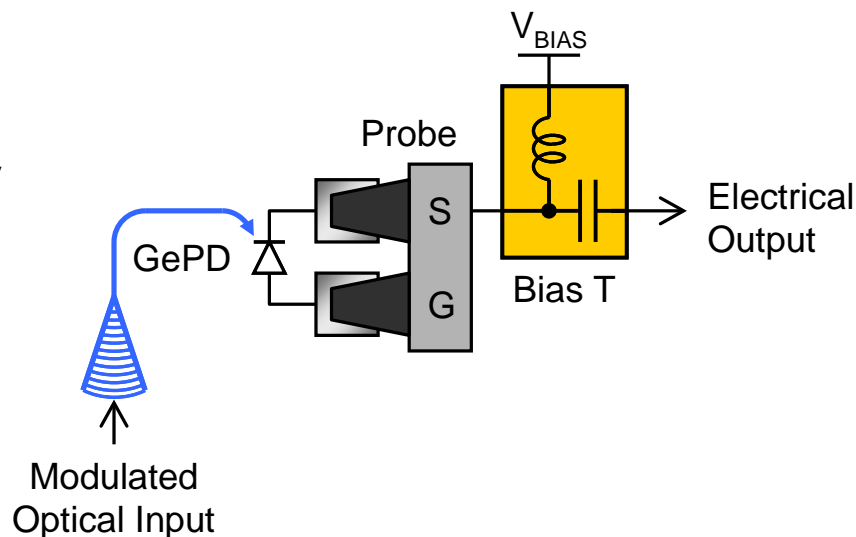

# Optical Transmission Channel - Overview

## Transmitter path:

- Single polarization grating couplers
- CMOS photonics waveguides & splitters combiners
- Mach-Zehnder interferometer
- Low-speed monitor photodiodes

## Interconnect medium:

- Broadband single mode fiber

## Receiver path:

- Polarization splitting grating coupler
- CMOS photonics waveguides
- High speed photodiodes

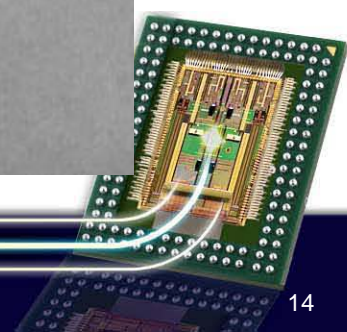
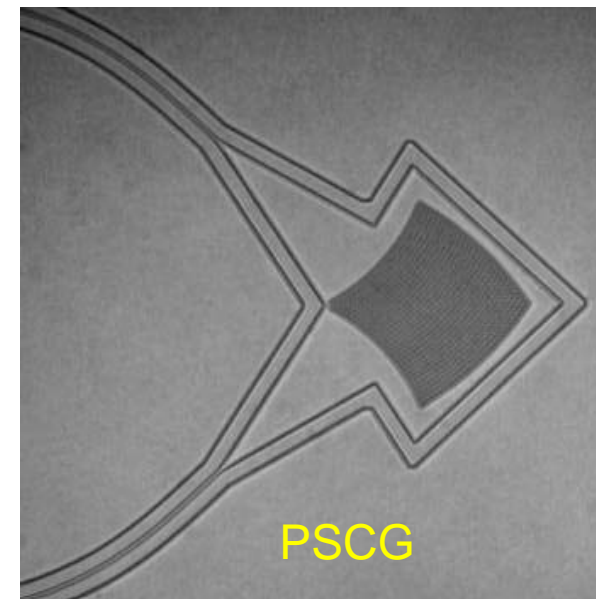
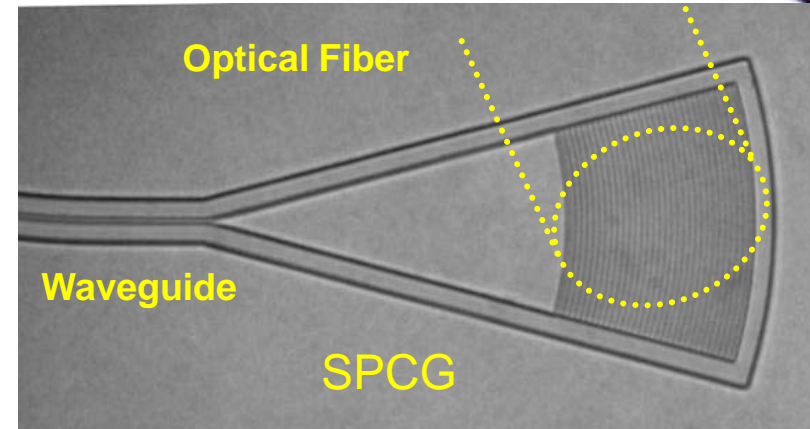

# Optical Transmission Channel - Characteristics

## Grating Couplers

- No discernible data rate dependence

## Waveguides & splitters/combiners

- On chip trace lengths a few cm long
- Dispersion effects significant only above 100m in length
  - Optical attenuation stronger factor than dispersion

## Single mode fiber

- Dispersion effects become evident at several km in length
- Negligible dispersion in short reach interconnects

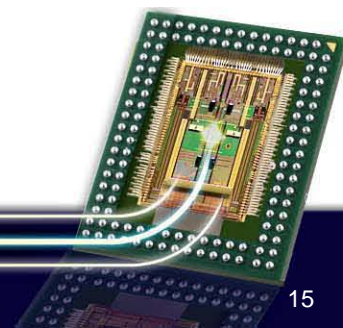

# Future Potential Applications

- **Single Channel Solutions:**
  - 16G Fibre Channel
  - 32G Fibre Channel
  - 40G Serial Ethernet?
- **4 Channel Solutions:**
  - 4x14G FDR InfiniBand
  - 4x25G EDR InfiniBand
  - 4x25G 100G Ethernet
  - 4x32G Fibre Channel Switch to Switch
- **12+ Channel Solutions:**
  - 12x25G EDR InfiniBand
  - 16x25G 400G Ethernet?
- **Embedded Solutions:**
  - 4/12/16 x 25G MCM mountable solutions
  - Optical backplane interconnects
- **3D Video Interconnects**



# Conclusions

## **CMOS Photonics is capable of serial data rates well beyond 25Gbps**

- Theoretical modulation limit of 320 Gbps
- Theoretical detection limit of 110 Gbps (with current photodiode depletion thickness)

## **CMOS Photonics rate capability directly correlated to host systems capability**

- Removes the possibility of interconnect being the limiting factor for new systems development for the foreseeable future.

## **CMOS photonics reaches reliability levels host system designers have grown to expect based on copper channels**

- Reliability limited by light source, which has a FIT < 1.

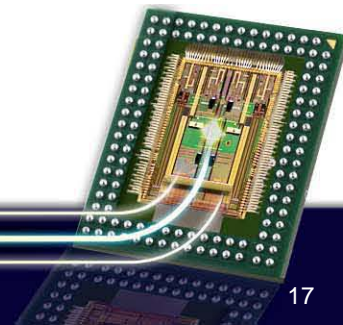

# Acknowledgements

## Luxtera Team Contributors:

Sherif Abdalla, Colin Bradbury, Peter De Dobbelaere, Dennis Foltz, Steffen Gloeckner, Drew Guckenberger, Mark Harrison, Steve Jackson, Daniel Kucharski, Michael Mack, Gianlorenzo Masini, Attila Mekis, Adit Narasimha, Mark Peterson, Thierry Pinguet, Subal Sahni, Dan Song, and Marek Tlalka

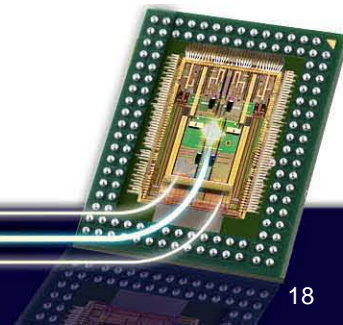

# Thank You!

